



ALPHACAM 2025.4

Release Notes

The image shows a license information card for ALPHACAM 2025.4. It has a green background with a subtle hexagonal pattern. In the top left corner, there is a circular icon containing a stylized black and white logo. Below the icon, the text "ALPHACAM" is written in bold, followed by "2025.4". Underneath, it says "Reseller License" and "NOT FOR RESALE". A larger line of text states "This product is licensed to Development" and "Update Expiry January 2027". At the bottom left, there is a copyright notice: "© 1989-2025 Planit Software Ltd. All rights reserved."

Loading Add-ins...



This document provides an overview of the new features and enhancements from one year of development, covering ALPHACAM 2025.1 through 2025.4.
10 February 2026

Contents

Overview	1
Machining	1
Simulation	1
Automation & Nesting	1
Reporting	1
General Enhancements	1
Useful Videos:	2
2025.4	2
2025.3	2
2025.2	2
2025.1	2
Release Notes 2025.4	3
Maintenance Report	3
What's New	5
Machining	5
Solid Simulation	9
General	11
Automation Manager	13
CAD	18
Nesting	20
Release Notes 2025.3	21
Maintenance Report	21
Whats New	23
Solid Simulation	23
Operations Manager	26
Operations Tab	32
Layers Manager	33
Automation Manager	34
Automation Manager and CDM	38
Quick Nest	39

General	42
Release Notes 2025.2	46
Maintenance Report	46
Whats New	47
Lathe	47
2D Leads.....	53
3D Machining	55
Tool Definition	56
Pocketing and Z Contour Roughing.....	57
Pocketing	58
Tool Library	59
Solid Simulation	60
Simulation	62
Radial Menu	63
Feature Extraction.....	64
Parametric Sketcher.....	65
Geometry	69
Dimension	70
Solid Models.....	71
Automation Manager.....	72
Nesting	86
Configuration.....	90
Reports.....	91
Release Notes 2025.1	94
Maintenance Report	94
Whats New	97
Rough or Finish.....	97
Advanced 5-Axis	98
Lathe	101
Sawing Toolpaths.....	104
Solid Simulation	105

Configuration.....	110
File	111
User Interface.....	111
Display Options.....	112
Automation Manager.....	114
Reports.....	124
Scale 3D XYZ.....	126
Appendix A - API Improvements in ALPHACAM 2025.1	127
Supported CAD File Versions.....	128
Translator and Version	128
Extra Cost.....	129
Translator and Version.....	129
Recommended System Specifications.....	130
System Requirements	130
Operating System	130
Microsoft .NET Framework	130
RAM	131
Graphics.....	131
Hard Drive	131
Display	131
Mouse	131
Connectivity.....	131
Licensing.....	131
Installation	131
Browsers	132
Windows ARM.....	132
Install ALPHACAM	133
Step 1: Check System and Hardware Requirements.....	133
Step 2: Log on as an Administrator	133
Step 3: Download ALPHACAM	133
Step 4: Install ALPHACAM	133

Update ALPHACAM	135
Contact Hexagon Manufacturing Intelligence.....	136

Overview

This topic provides a summary of the key features and enhancements introduced over one year of development, covering versions ALPHACAM 2025.1 through 2025.4.

Machining

ALPHACAM introduces improvements that make machining faster and more controlled. A key addition is the Minimum Length parameter in Cut Path, which removes unnecessary short toolpaths when taking account of previous machining, saving time, and reducing traversal. Lathe operations are easier with new Pick Buttons in Part Off, Facing, and Turning cycles, allowing Z and Diameter levels to be selected directly from the drawing. Pocketing gains advanced control with G41/G42 compensation for Finish Passes, while ramp entry is optimised using tool-defined Centre Cutting and Maximum Plunge Depth parameters. The familiar Rough or Finish cycle is now unified as Cut Path, creating consistency across all modules. Combined with improved 3D Machining performance for large models, these updates deliver smoother workflows and better results. Advanced 5-Axis machining has been updated with the newest libraries, including more types of Tool definition, improved tool axis control, and enhanced gouge checking.

Simulation

Simulation is more powerful and intuitive. Solid Simulation stock comparison enables visual checks against the original model, with adjustable ranges and colours for accuracy. Sectioning now includes the part for clearer inspection, and speed sliders feature a lock option for combined Feed and Rapid control. Additional refinements include improved part visibility and progress dialogs for mesh repairs, making simulation easier to manage.

Automation & Nesting

Automation Manager and nesting workflows are smarter than ever. Enhanced alignment options and streamlined Layer Mapping improve flexibility for complex jobs, while support for Parametric Sketch Fittings adds versatility to automated processes. Quick Nest now supports creating and exporting Nest Lists, along with full support for nesting toolpaths, delivering a significantly improved on-screen nesting workflow. It now also uses the Advanced Nesting engine, providing more complete functionality and improved material yield.

Reporting

Reports are more visual and informative with Filled Colour images for Parts and Nested Sheets, making part identification faster and clearer. Other new options include Nested Part Placement Images, helping users quickly locate parts on sheets for labelling and production.

General Enhancements

The new Hexagon Universal Updater makes staying current effortless, providing streamlined updates and easy access to resources. Additionally, a Windows 10 installation warning has been added as Microsoft ends support, ensuring users are informed before setup. Workflow and clarity have also been improved in the Operations Manager, with better geometry selection, operation reordering, and naming options for clearer project organisation. Combined with improved solid model and wire-frame geometry rendering, updated Radial Menu defaults, and enhanced geometry handling, ALPHACAM 2025 delivers practical improvements that make everyday use more efficient and consistent.

Useful Videos:**2025.4**[Fittings Support for Parametric Sketches in Automation Manager](#)[New Usability Improvements for 3D Edge Extraction](#)[Cut Path, Minimum Length Parameter for Maximum Efficiency](#)**2025.3**[Quick Nest Enhancements](#)[Introducing the Hexagon Universal Updater](#)**2025.2**[Solid Simulation Part Compare](#)[Pocketing Simple Finish and Leads Start at Circle Center](#)[Minimum Bounding Box Alignment](#)**2025.1**[Saw Display Option](#)[Coloured Reports](#)[Automation Manager Workflow Enhancements](#)**See Also**

[Release Notes 2025.4](#)[Release Notes 2025.3](#)[Release Notes 2025.2](#)[Release Notes 2025.1](#)

Release Notes 2025.4

Maintenance Report

The following is a list of bug fixes and enhancements implemented in ALPHACAM 2025.4:

ID	Description	Closing Notes
28635	Edit Machining - Support Tag - Ramped Support Tags are not recognised as Tags.	Fixed.
28702	Machining - Machine Holes - If a tool is selected with Tool Number 0 and Offset 0, the operation cannot be edited until ESC.	Fixed.
32361	Quick Edit - Tapping feed rate is not updated when spindle speed is modified.	Fixed.
32931	Advanced 5 Axis - Updating Advanced 5 Axis Toolpath on a Work Plane creates new Work Plane.	Fixed.
35745	Lathe - Material Cut on XZ work plane - Geometry, Splines, Text, and Dimensions obscured.	Fixed.
40753	Export DXF is wrong if the Geometry is in a Workplane.	Fixed.
40998	GUI - Copy/Move Text - Text is not shown when a Copy is made and zoomed out until screen Refresh.	Fixed.
41545	Solid Simulation - Collisions not detected depending on speed.	Fixed.
44642	Automation Manager - Align by Minimal Bounding Box - Incorrect Resulting Part Orientation.	Fixed.
44644	Automation Manager - Reverse Side Nesting - Second Layer Setting - Query not applied.	Fixed.
44665	SimNC - Improve transfer speed of target part.	Implemented.
44675	Automation Manager - CSV Import - Newly created jobs are not highlighted.	Fixed.
44800	Automation Manager - Rev side sheets are not saved.	Fixed.
44868	Wire Module – Project Manager switches to the Simulator page and toolpaths are no longer drawn.	Fixed.
45068	Automation Manager - Part Alignment Issues.	Fixed.
45082	Managed Rapid - Toolpaths not updating after deleting Managed Rapids resulting in incorrect NC output.	Fixed.
45086	Styles - Slow to Open and Apply Styles containing many operations using Solid Tool Holders.	Fixed.
45112	Automation Manager - Nest Part Rotation Method - Creates unwanted Work Planes.	Fixed.
45170	Automatic Rapid Manager - Math functions are not correctly considered if user presses Enter.	Fixed.
45234	Applying Style takes very long in 2025 comparing to 2024.	Fixed.
45372	Universal Updater – Language not set by ALPHACAM Installation if Directory Doesn't Exist.	Fixed.
45453	Universal Updater - Installing Simplified Chinese doesn't set the Correct Language.	Fixed.
45458	Edit Text - Dialog has a graphical issue after Windows Update.	Fixed.
45470	Automation Manager - Solid Part Alignment and Nest Part Rotation on Import.	Fixed.
45505	Reports - Label - Hatched Part Preview in Nest not shown.	Fixed.
45509	Automation Manager - CSV Import - Incorrect Numeric Values.	Fixed.
45510	Nested Sheet Area Estimate - Fails When Cut Path Has Support Tags.	Fixed.
45535	Installation - Aspire for ALPHACAM is always installed in English.	Fixed.

45562	Solid Simulation - Part Compare - Machine visibility effects the result.	Fixed.
45569	Chamfering - Prompt bar Text has changed for Solid Edges in 2025.3.	Fixed.
45594	Nest - Sheet Bobble Overlapping.	Fixed.
45649	Automation Manager - Not Using Solidlink DXF Translator when it should.	Fixed.
45660	Solid Simulation - Incorrect movement between operations for Rotary Table.	Fixed.
45667	Quick Nest - Run-time error.	Fixed.
45668	Feature Extraction - Wrong Body Outlines.	Fixed.
45670	Solid Simulation - Use Tool Profile - Incorrect Collision Reported.	Fixed.
45674	Solid Simulation - Improved Black Edge Rendering for Machines and Fixtures.	Fixed.
45715	Automation Manager - CSV Import - Nest Part Rotation Methods Incorrectly Modified when Part Alignment specified.	Fixed.
45727	3D Machining - Lead In/Out and Links - Join Paths with Arcs remains toggled and is accounted for even when Specify Moves Between Cuts is not toggled.	Fixed.
45769	NC Output - Post Variable NOC is incorrect with multiple geometries within a Saw Operation.	Fixed. (Operation needs updating.)
45771	2D Geometry Operations (for example, Facing) - If associated Geometry is deleted, the option to reselect Geometry in the operation is not available.	Fixed.
45800	Feature Extraction - 3D Edge Extraction - Unselected Line added if under mouse and F4 is pressed.	Fixed.
45803	Nesting - Part with Sawing can only be nested if Ignore 3D Paths is checked.	Fixed.
45814	API - App.OpenDXFFile Does Not Give Indication of Errors.	Fixed.
45815	API - App.OpenTempDxfFile does not return all Layers in the file.	Fixed.
45816	File Browser - Will not show some DXF files.	Fixed.
45885	Updated SOLIDWORKS Document Manager.	Implemented.
46177	Add-ins - VBA Add-ins containing "Browse for Folder" functionality are crashing ALPHACAM.	Fixed.

What's New

Machining

Machine along Spline or Polyline - Remember 3D Lead-In/Out Settings

When you create new instances of the **Machine Along Spline/Polyline** operation, the **3D LeadIn/Out** settings are automatically set to the values last used for this operation type. The settings are retained for the duration of the application session.

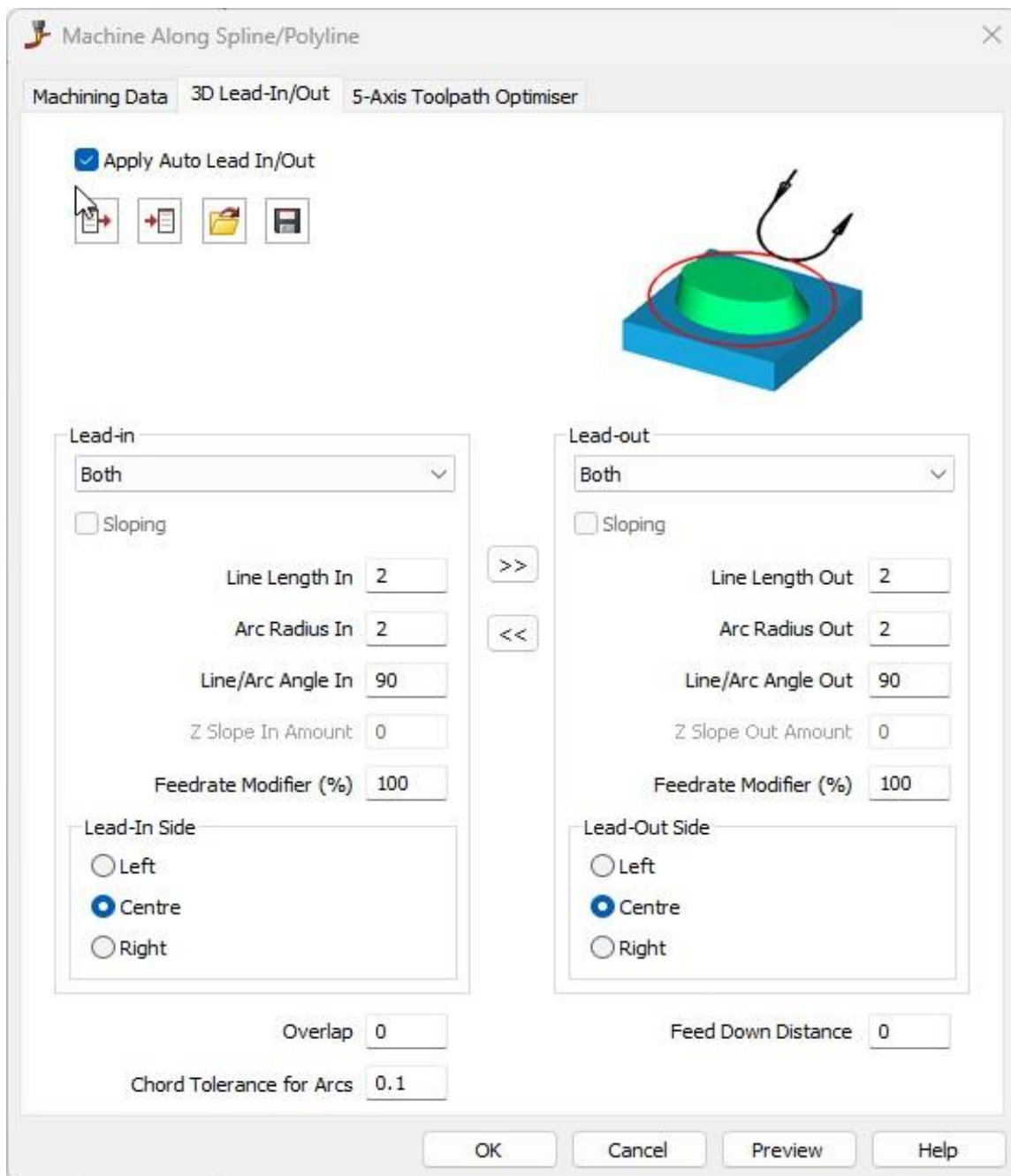

Edit Machining - Support Tags - Combined Tag Type

Added the **Combined** option and **Ramp Angle** box in the **Support Tags** dialog box.

- The **Ramp Angle** box is only available when the **Combined** option is selected.

The ramp angle must be greater than zero and less than 90 degrees.

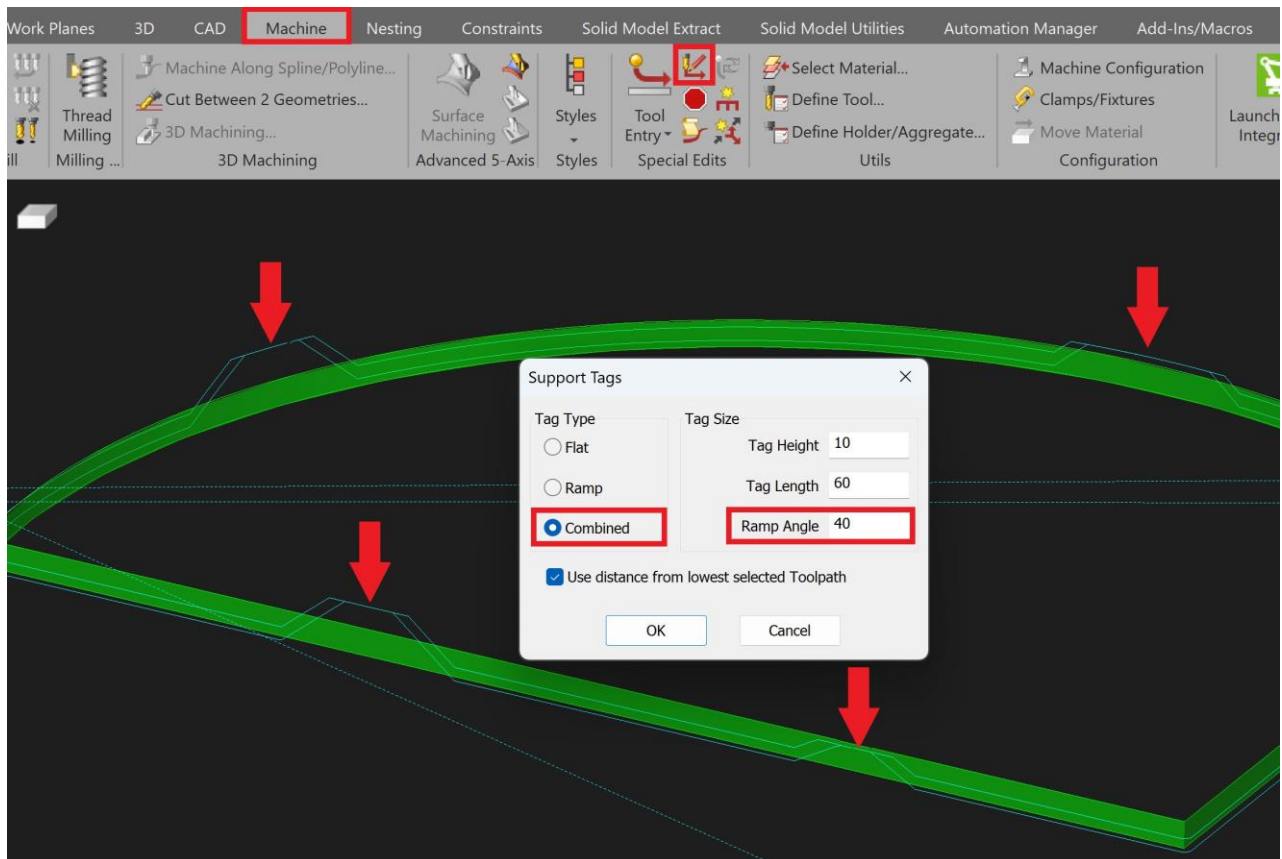

A message is displayed when tags are applied to indicate if a tag cannot be placed, for example, when the ramp angle is too shallow to fit within the specified tag length.

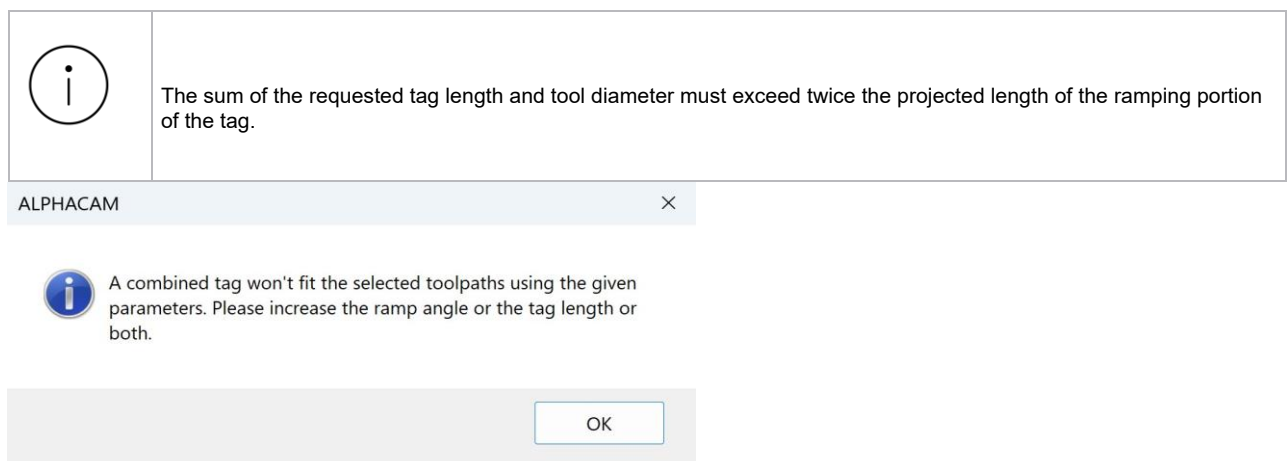

Cut Path – Take Account of Previous Machining – Minimum Length Parameter for Reducing Machining Time

Added the **Minimum Length** box to the **Take Account of Previous Machining** check box in the **Cut Path** dialog box. When you select the **Take Account of Previous Machining** check box, ALPHACAM automatically removes any toolpaths shorter than the specified minimum length.

This helps eliminate unnecessary small toolpaths and reduces traversal time.

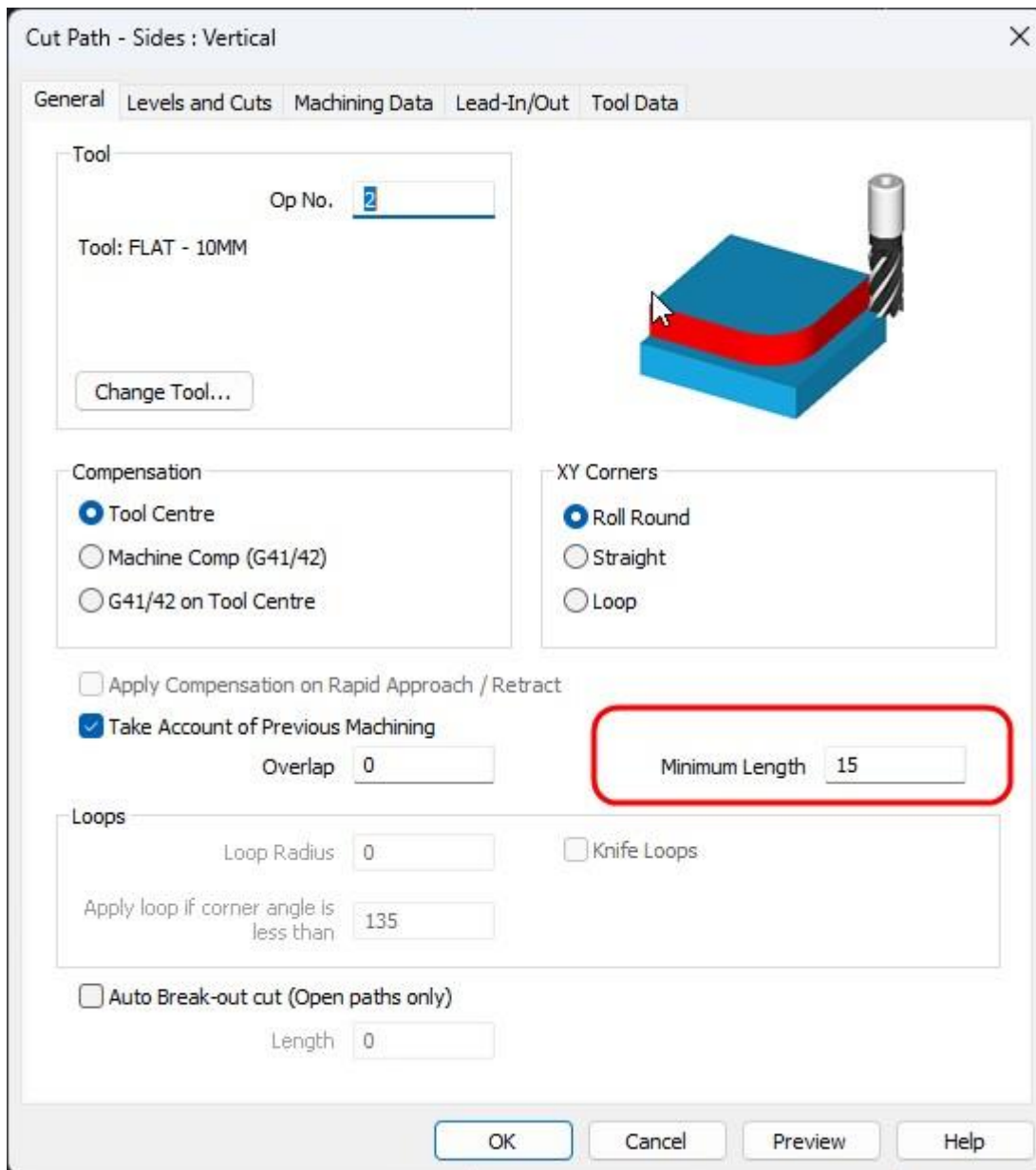

In the example, the T-bone fillets still require finishing, while the internal corners do not need further machining. The **Minimum Length** parameter can be used to remove excess toolpaths.

Before

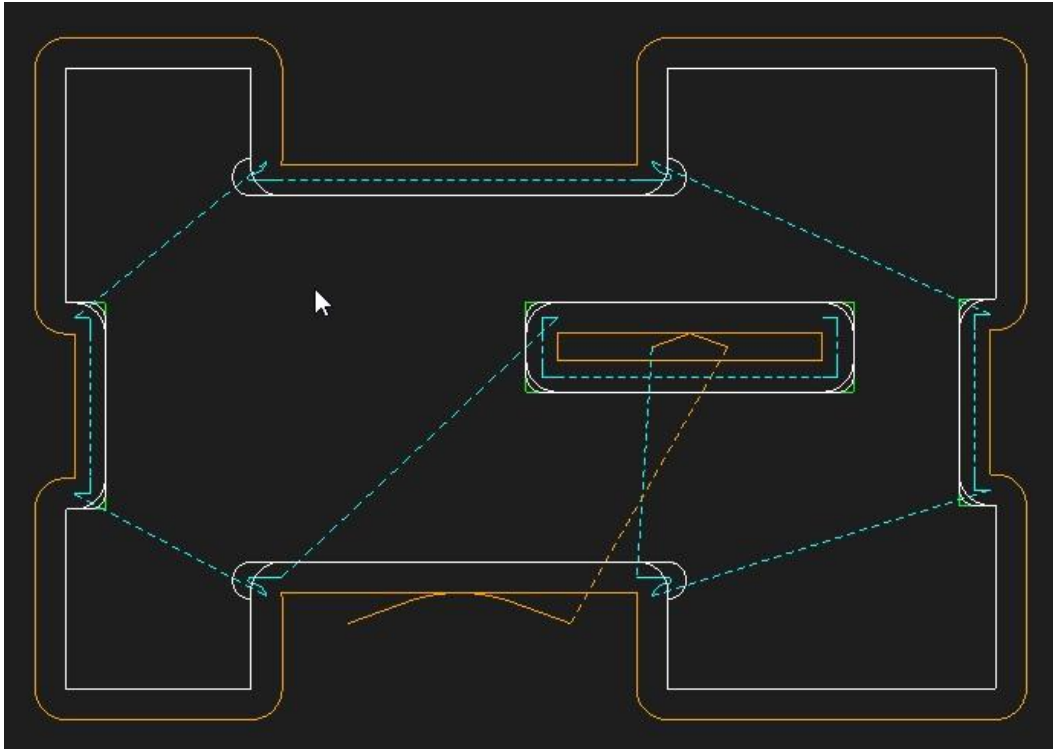

After

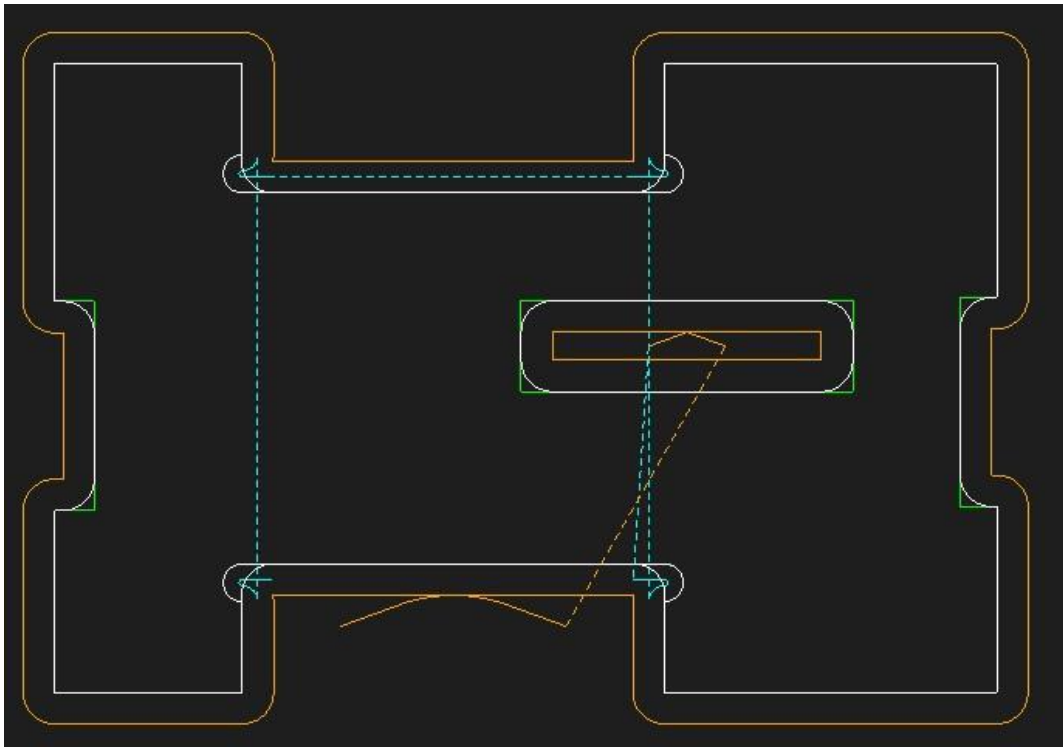

Solid Simulation

Solid Simulation – Added Repair Progress Dialog and Cancel Button

When ALPHACAM needs to repair a mesh material (.stl) for SimNC, a dialog now appears that shows a progress bar and counter. If multiple materials require repair, the dialog is displayed sequentially for each material as required.

The Repair Progress dialog includes the **Cancel** button or the Close (X) button at the top of the dialog. If cancelled, the repair process stops immediately, and ALPHACAM proceeds either to the next material or directly to simulation.

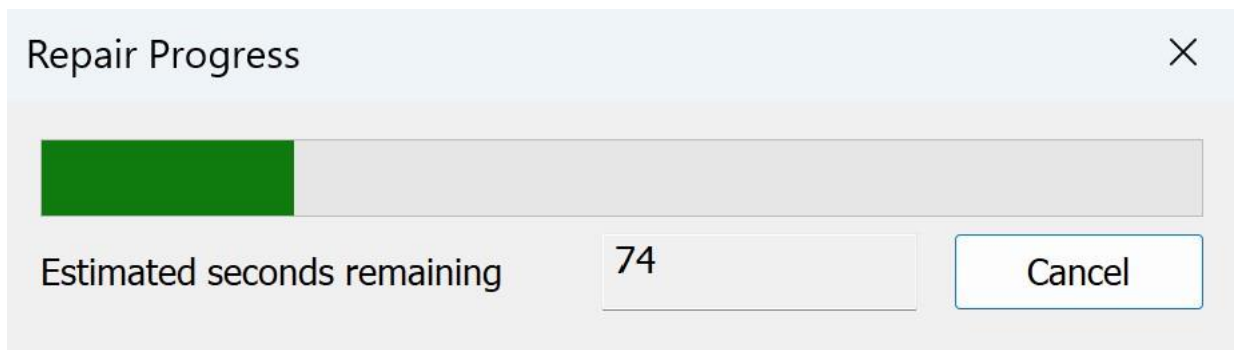

Solid Simulation - Lathe - Integration Updates (Preview)

In the Lathe module, the new Solid Simulation is in development and available as a preview through the Simulation Configuration settings.

Developed Work Planes: Developed Work Plane Milling is now supported in Solid Simulation for Lathe, ensuring alignment with the legacy Solid Simulator.

Sectioning: The new Solid Simulator introduces improved sectioning behaviour for the Lathe module.

You can now keep the Sectioning command active during simulation, making it easier to visually inspect toolpaths and material removal at any stage of the process.

On first launch, the simulator applies default sectioning settings of the YZ plane with the near-side section removed, providing a clear view of internal features.

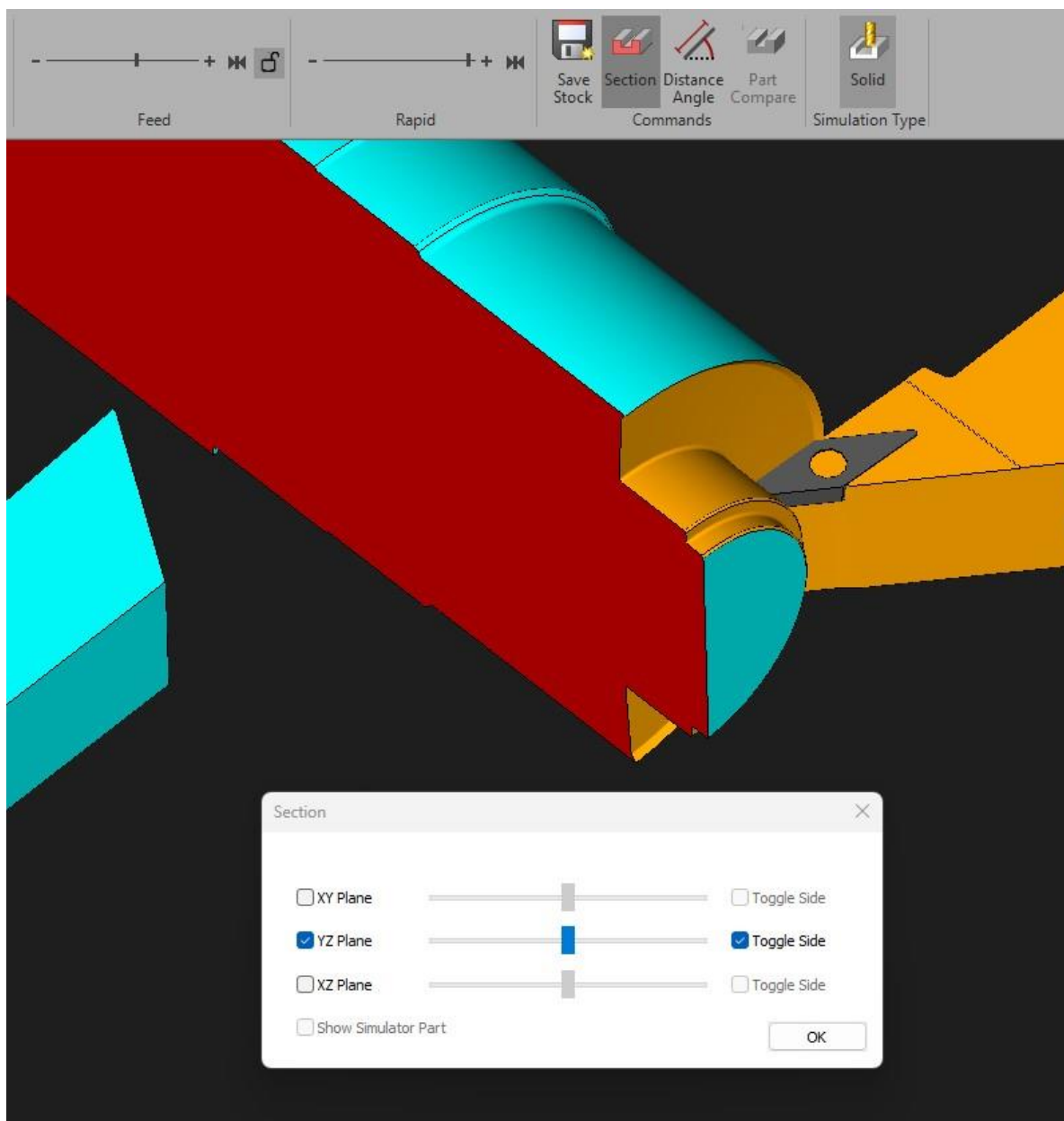

General

Line Widths - Use Line Width when Highlighting and Selecting

As an improvement to the highlighting of selected paths, elements, and similar items to support the full line width, replacing the previous single pixel highlight for better visibility and user experience.

When selecting or hovering over a path or an element within it, the entire path or element is now highlighted using the same thickness as the original. This behaviour occurs when selecting paths or elements from the **Layers > Work Planes > Operations** pages, and when using commands such as **Move**, **Copy**, **Offset** (for paths and elements), **Fillet**, and others.

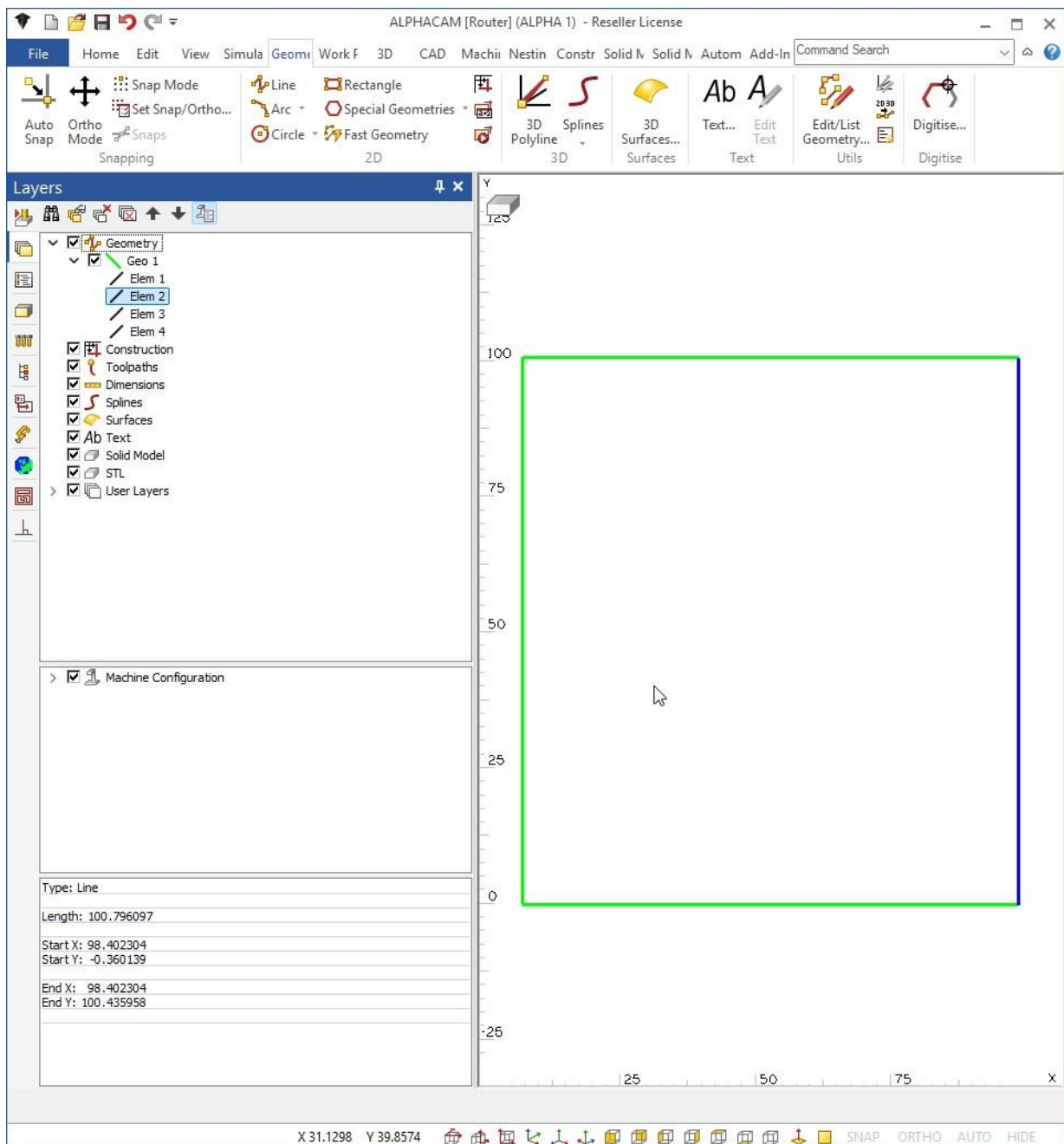

Styles - Display Custom Operation Names

When expanding a style to view its individual operations, ALPHACAM now displays the custom operation name (if defined when the style was saved) instead of the default operation name.

	The Tool name continues to be appended to the operation name.
---	---

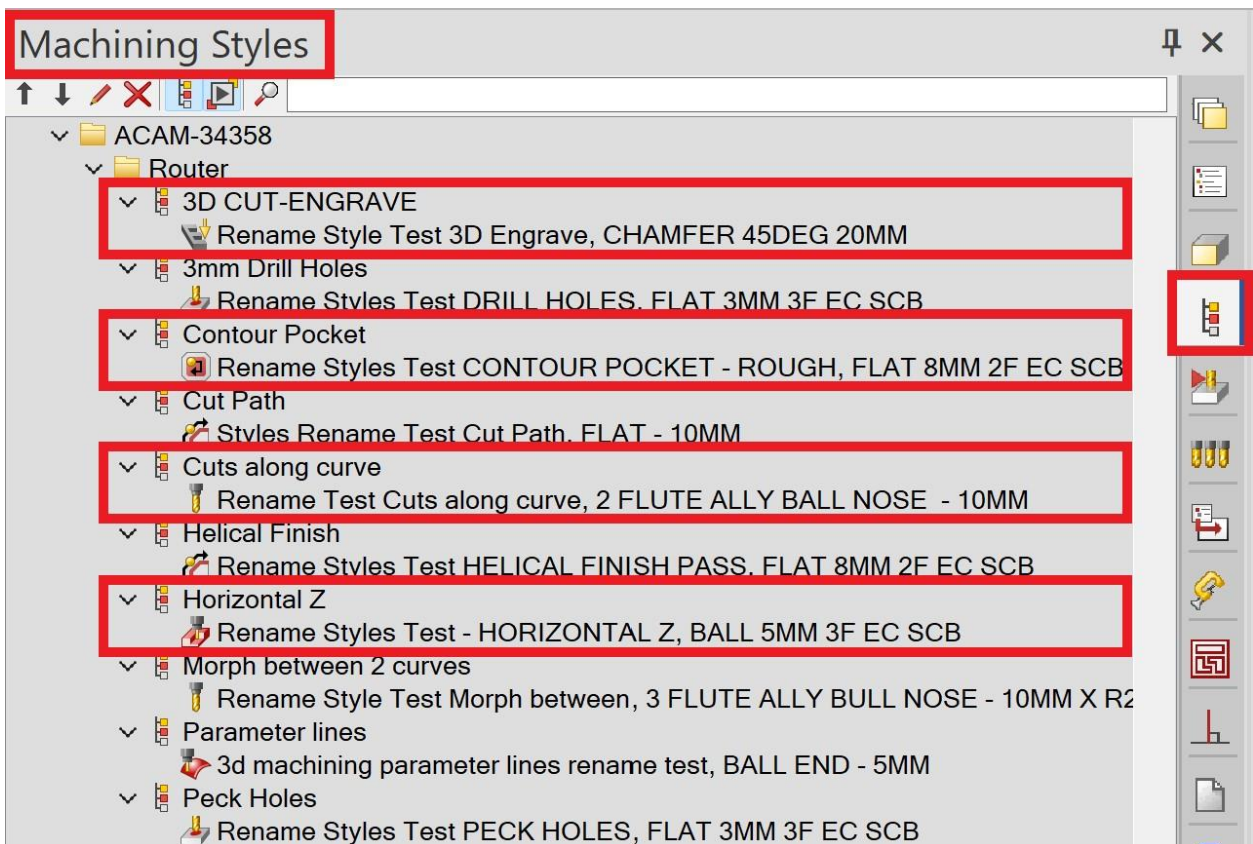

Automation Manager

Automation Manager – Part Offset X and Y

The **Part Offsets** section has been added to the **Configuration** tab. The section includes the **Part Offset X** and **Part Offset Y** parameters.

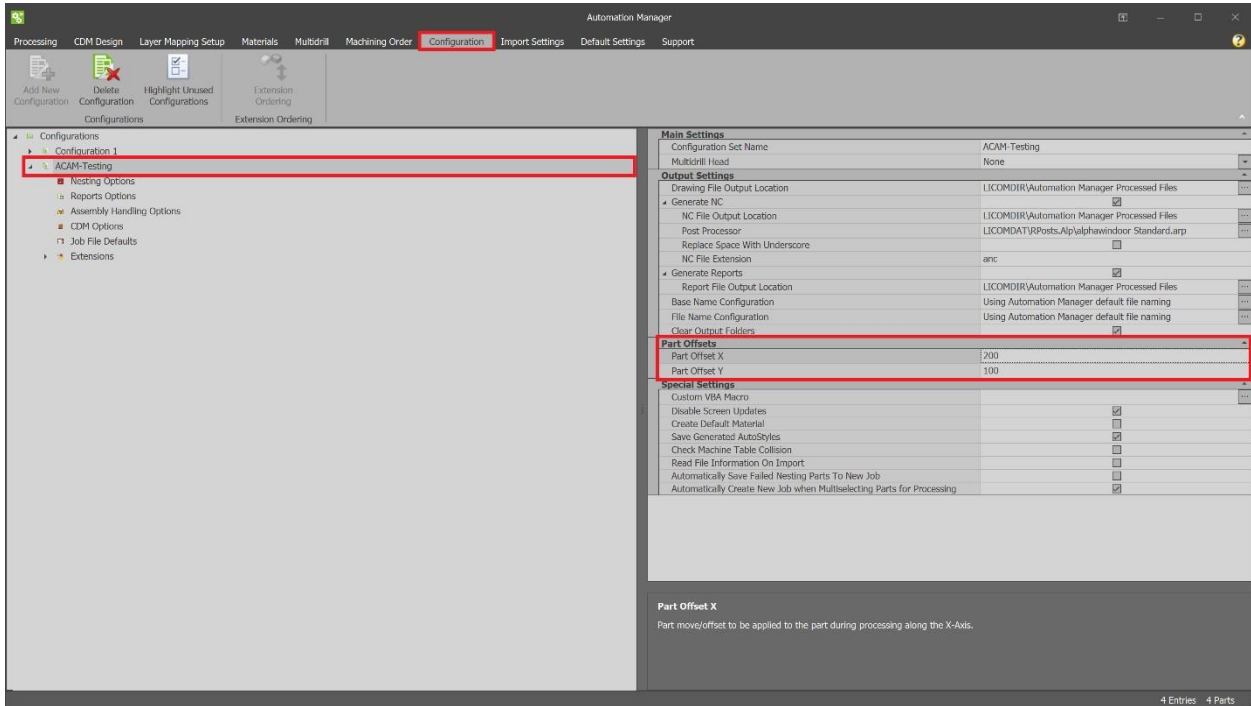

By default, both values are set to 0, meaning no offset is applied. When a non-zero value is entered, the generated parts are shifted by the specified amount. This offset applies to part drawings in both nested and non-nested jobs.

	<p>3D drawings containing work plane paths are moved globally, which requires the xPositional license multiplier.</p>
---	---

No Offsets Defined

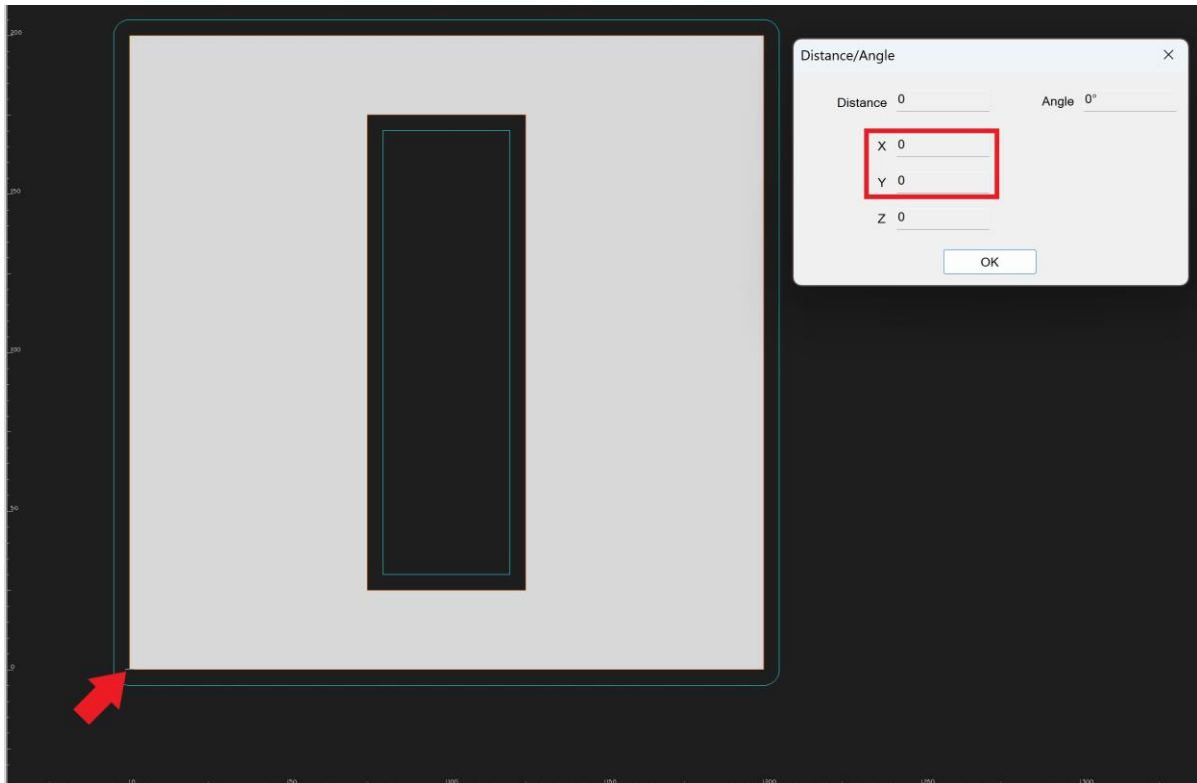

Offsets Defined



Automation Manager - Support Parametric Sketch Fittings

As an improvement to Automation Manager, it is now possible to assign fittings to Parametric Sketcher (.aeps) files.

- Default fittings can now be assigned and cleared for .aeps files, just as they can for standard ALPHACAM drawings.
- CSV import is supported for both .aeps files and fittings.

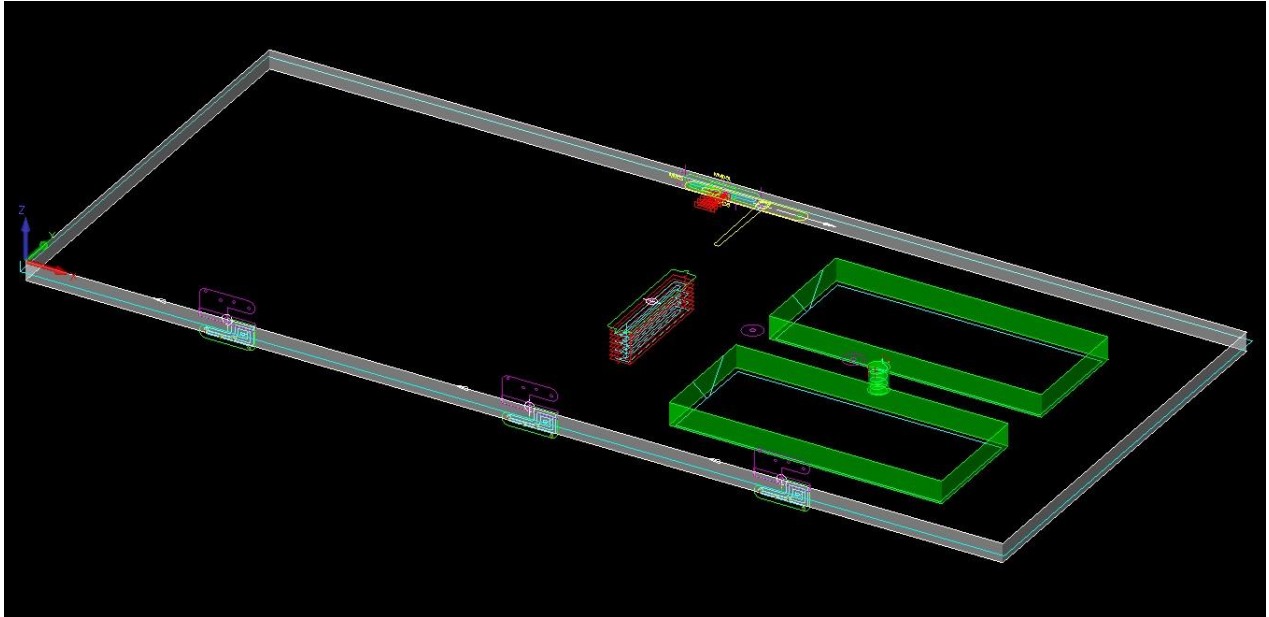

Automation Manager - Password Protection for Default Settings

In the **Default Settings** tab, you can now set a password to prevent users from editing the defined Automation Manager defaults. When you select the **Lock Settings** button, a dialog box appears where you can set a password and provide a memorable question and answer.

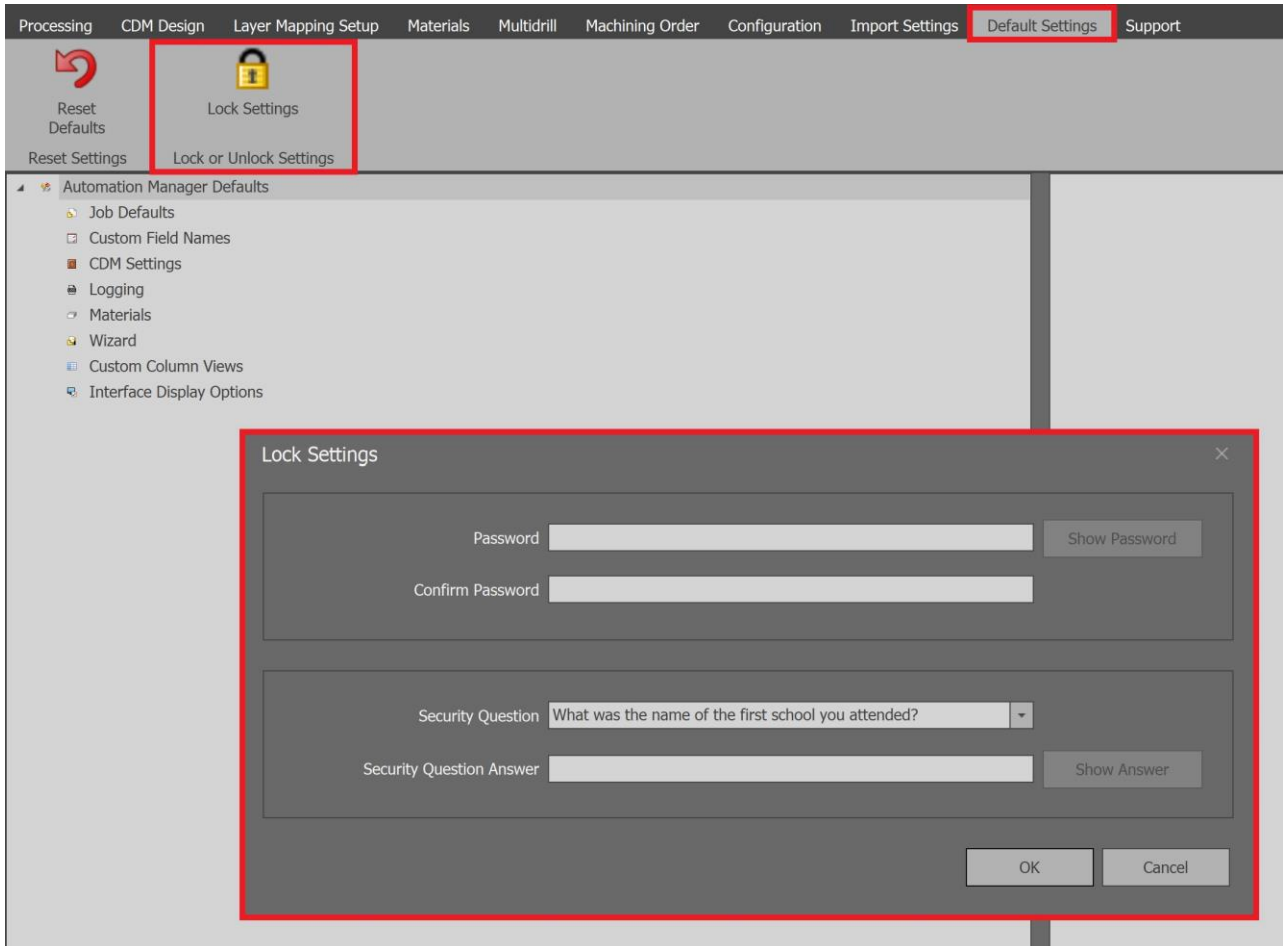

Once a password is set, all nodes are hidden from the tree. They can only be accessed by entering the correct password. When the password is entered, all nodes become visible and the settings are editable.



A **Forgotten Password** option has been added to the dialog box. This allows you to unlock the settings and the **Set Password** dialog by entering the correct answer to the security question.

- When unlocking settings, select the **Clear password data after unlock** check box to clear all stored password data.
- When you lock the settings again, you must re-enter all security information, including Password, Confirm Password, Security Question, and Security Answer.

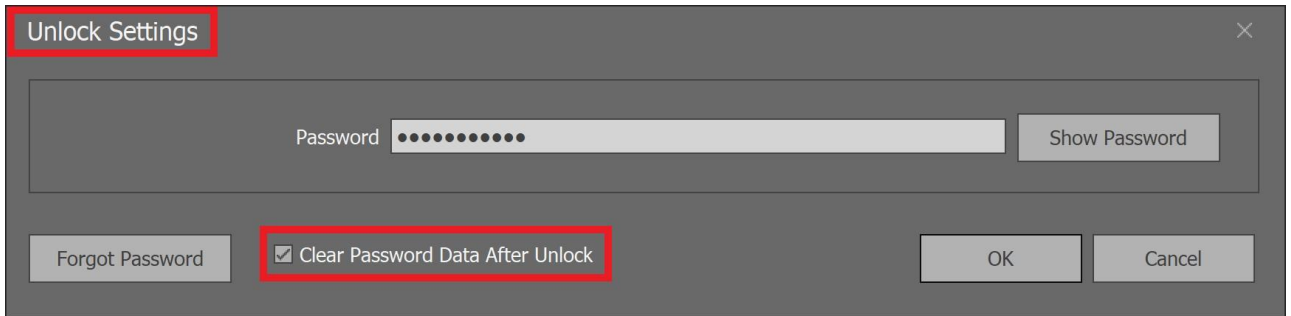

The screenshot shows a dialog box titled "Unlock Settings". At the top left, the title "Unlock Settings" is highlighted with a red box. Below the title bar is a password input field labeled "Password" with a "Show Password" button to its right. At the bottom of the dialog, there are four buttons: "Forgot Password", "Clear Password Data After Unlock" (which has a checked checkbox and is highlighted with a red box), "OK", and "Cancel".

If a password is set, unlocking the settings without selecting the checkbox unlocks them for the current Automation Manager session only. When you restart Automation Manager, the settings are locked again.

If the security questions fail and you can't access the default settings, contact support. They can unlock the settings for you.

CAD

3D Edge Extraction and Contour from Picked Edges - Back or Undo Option while Selecting

The 2D and 3D edge extraction feature has been improved to include the ability to undo the last selection.

A tangential run of edges is now found only when you press the **Shift** key to select individual edges in a tangential run.

When you move the mouse over edges that can be added to the current selection, they are highlighted to distinguish them from the edges that are already selected.

The last set of selected edges are drawn in white and selecting any one of them removes them and restores the previous selection.

A blue marker is now displayed only on the **start** vertex. The vertex closest to the mouse pointer at other times is no longer relevant. If you want a tangential run and have pressed the **Shift** key, you get a run of edges regardless of which end of the edge you are closest to.

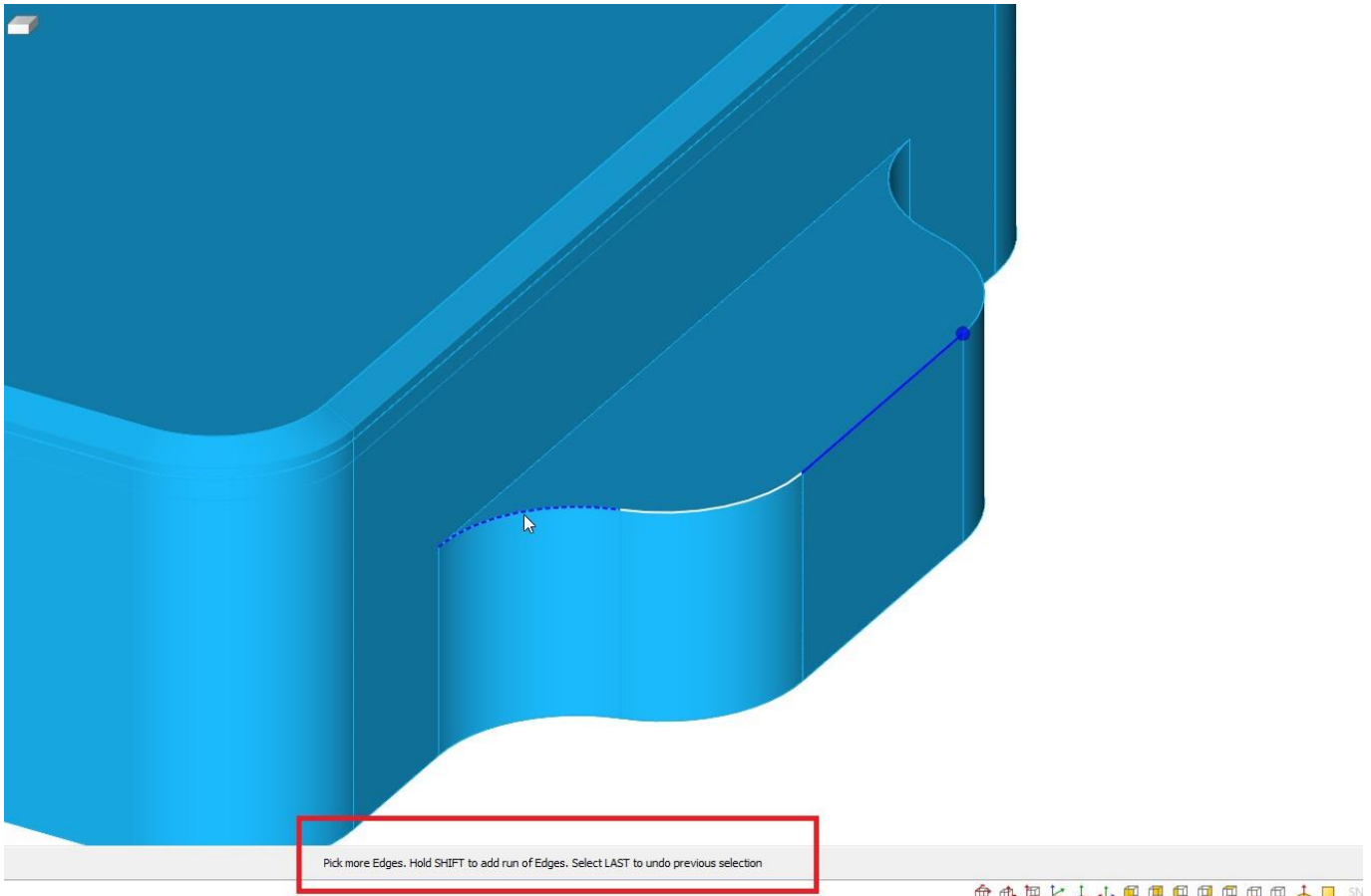

10 February 2026

18

3D Edge Extraction and Contour from Picked Edges - Use Start Point

The 3D Edge Extraction and Contour from Picked Edges has been enhanced to use the start point.

- **3D Edge Extraction** - The extracted polyline now starts at the point where the blue ball is displayed when picking edges.
- **Contour from Picked Edges** - The extracted 2D geometry now starts at the point where the blue ball is displayed when picking edges.

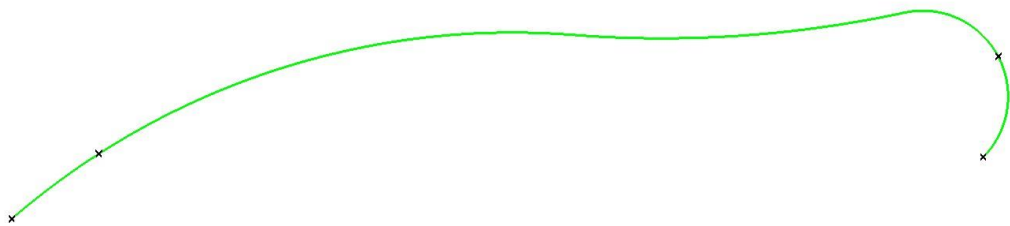

Edit - Break at Distance - Option to Break at Distance from End

The **Edit > Break, Join, etc > Break at Distance** has been improved to support breaking at a distance from either the start or end of an element, based on the mouse pointer position. Small crosses now appear to indicate the break points, giving a clear visual confirmation of what has been created.

Additionally, real-time updates have been added to the **Layers** project page.

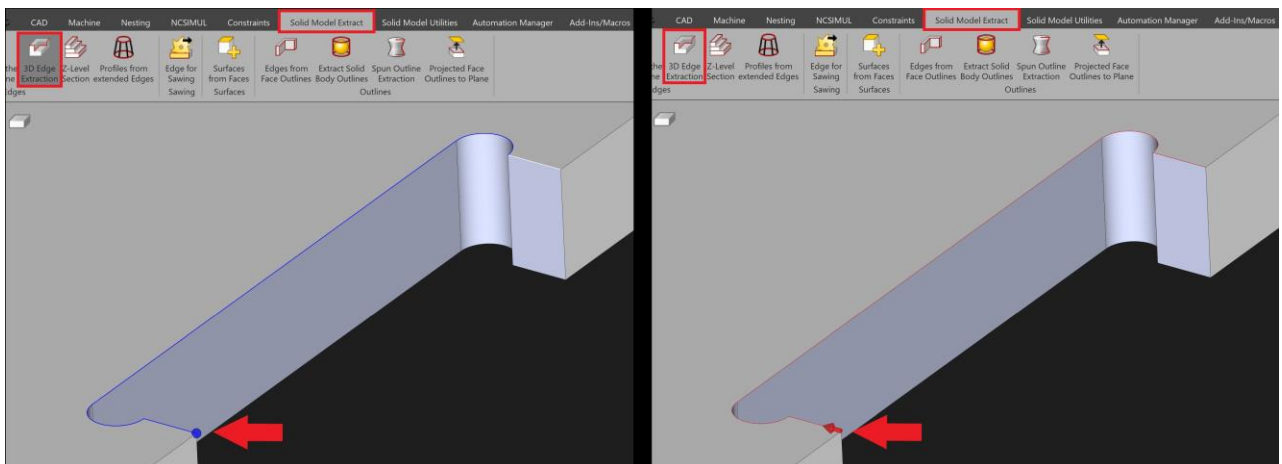

Nesting

Area Estimate for nested sheets now includes a new field that reports offcut area, enabling a more accurate calculation of total scrap percentage.

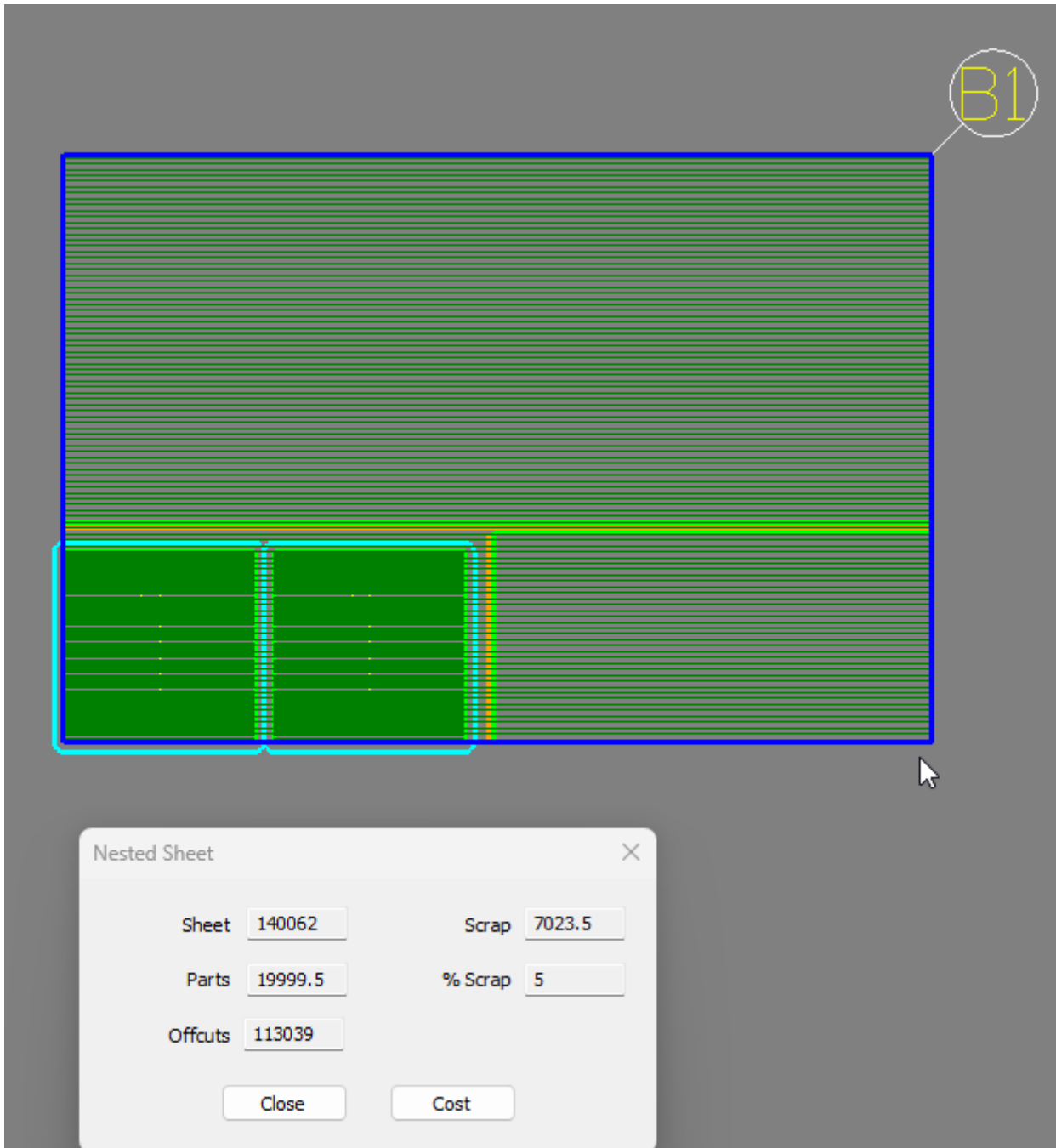

Release Notes 2025.3

Maintenance Report

The following is a list of bug fixes and enhancements implemented in ALPHACAM 2025.3:

ID	Description	Closing Notes
10662	Lathe - Diameter Groove - Additional Offset Box missing from Updated dialogs in 2018R1.	Fixed.
19664	Edit Feed Rate - Modifying an existing point causes toolpath to move in Z.	Fixed.
21190	Insert - Line Type is lost after inserting.	Fixed.
32883	Licensing - Clipboard files created in an educational version cause an error when commercial version launched.	Fixed.
37944	Change - Stops responding when changing Toolpaths into Geometry.	Fixed.
39021	Cut between two Geometries - Tool data is not updated when Change Tool is used.	Fixed.
39023	Nesting - Support Tags - Tags should be applied to each section of a Bridged Nesting Toolpath inside the selection circle.	Fixed.
39897	Pocketing - Max Depth per Cut - Uses wrong tool parameter.	Fixed.
40861	Z Contour Roughing - Detect Understock - Result in 2024.2 leaves areas unmachined leading to collision.	Fixed.
41271	Pocketing - Take account of Previous Machining - Whole area Pocketed.	Fixed.
42113	Nesting - Save Nest List on Close or New changes settings.	Fixed.
43566	Chamfer - Solid Faces - Maintain Geometry Order can cause ALPHACAM to hang.	Fixed.
43665	Solid Simulation - Incorrect clamp movement.	Fixed.
43715	Styles - ALPHACAM slower when styles project page is visible.	Fixed.
43787	Solid Simulation - A single operation cannot be simulated when using Automatic Rapid Manager.	Fixed.
44034	Pocketing - Finish Pass fails where Pocketing succeeds.	Fixed.
44170	Constraints - Parametric Rules - Add rule immediately after cancelling a rule that deletes all existing rules.	Fixed.
44186	Solid Simulation - Lathe - Improved default view.	Implemented.
44193	Solid Simulation - Tolerance not being used.	Fixed.
44215	Thread Milling - Lead In/Out - Arrows to transfer Feed rate working in reverse.	Fixed.
44221	Automation Manager - CSV Import - Newly created job is not added to the correct position when Alphabetical Ordering is active.	Fixed.
44228	Automation Manager - Import Files into Job - Unhandled exception in middle tree of Processing.	Fixed.
44229	Solid Simulation - Update to the latest SIMNC.	Implemented.
44232	Simulation - Files created in the TEMP folder are not removed causing Simulation to stop working.	Fixed.
44233	Solid Simulation - Previously set tool holders are no longer shown in Solid Simulation.	Fixed.
44369	Automation Manager - Missing icons when form is resized – 'Highlight Unused' Setups/Machining Orders.	Fixed.
44410	Automation Manager - xSolid Module required for DXF Processing.	Fixed.

44413	Automation Manager - Some File Naming options can delete ALL files.	Fixed.
44527	Automation Manager - Machine Style Ordering List – Multidrilling.	Fixed.
44547	User Interface - Fast Geometry pop-up menu permanently disabled.	Fixed.
44799	Reports - Automation Manager - Work Planes in second sheet cause reports to crash on generation.	Fixed.
44814	Incorrect version of the English What's New document.	Fixed.
44863	Automation Manager - Error when creating Support file.	Fixed.
45071	Solid Simulation - Lathe - Measure command not working.	Fixed.
45114	Universal Updater - Set to installed language.	Implemented.

Whats New

Solid Simulation

Solid Simulation - Information List - Operation Note and Coolant added

The information list displayed during simulation has been enhanced to include the Operation Note (**Op Note**) and **Coolant** options.

i

These options are dynamic and only appear when the drawing contains visible operations with Operation Notes or with Coolant options not set to **None**.

Simulation
⌵ ×

Tolerance

Transparency

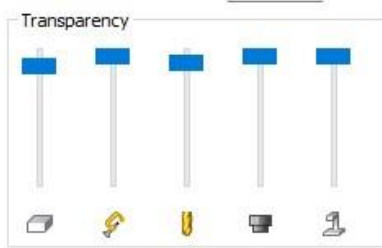

Name	Value
Tool	1
Tool Name	D 118 HSS D 2
Coolant	Through Tool
Op	3001
Op Name	DRILL HOLES
Op Note	FRONT FACE C AXIS DRILLING
Spindle	1000
Feed	1000.000
X	0.000
Y	0.000
Z	0.000
A	0.000
B	0.000
C	0.000

State	Reason
Paused	User

#	Collision
1	Tool & Material
2	Tool & Material
3	Tool Holder & Material
4	Tool & Material

Solid Simulation - Information List - Part Compare - Load/Save settings and defaults

Part Compare in Simulation has been improved so that the user can Set / Load default settings to suit their required accuracy and also Load and Save them as setting files (*.aPartCompare) defaults to Licomdat folder.

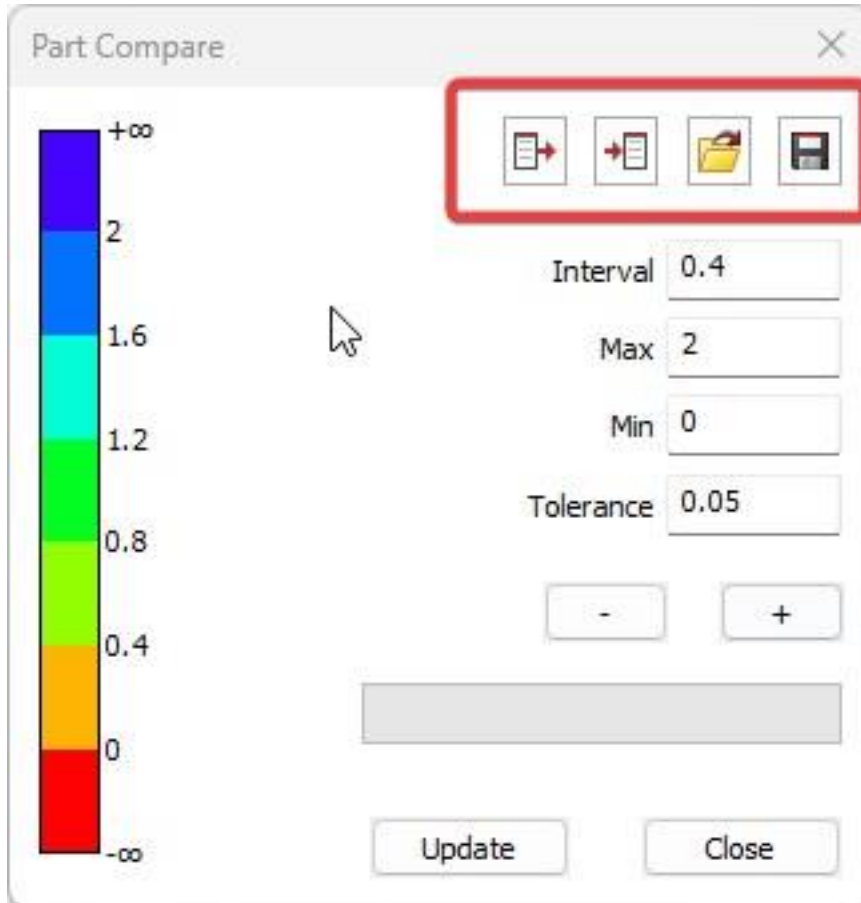

Solid Simulation - Part Compare - Support Multiple Simulator Parts

Part Compare in Solid Simulation has been improved and the user can now compare multiple simulator parts. The solid models to be compared must be configured as **Set as Simulator Part** from the right-click context menu of the Solids node in the **Layers** tab of the Project Manager.

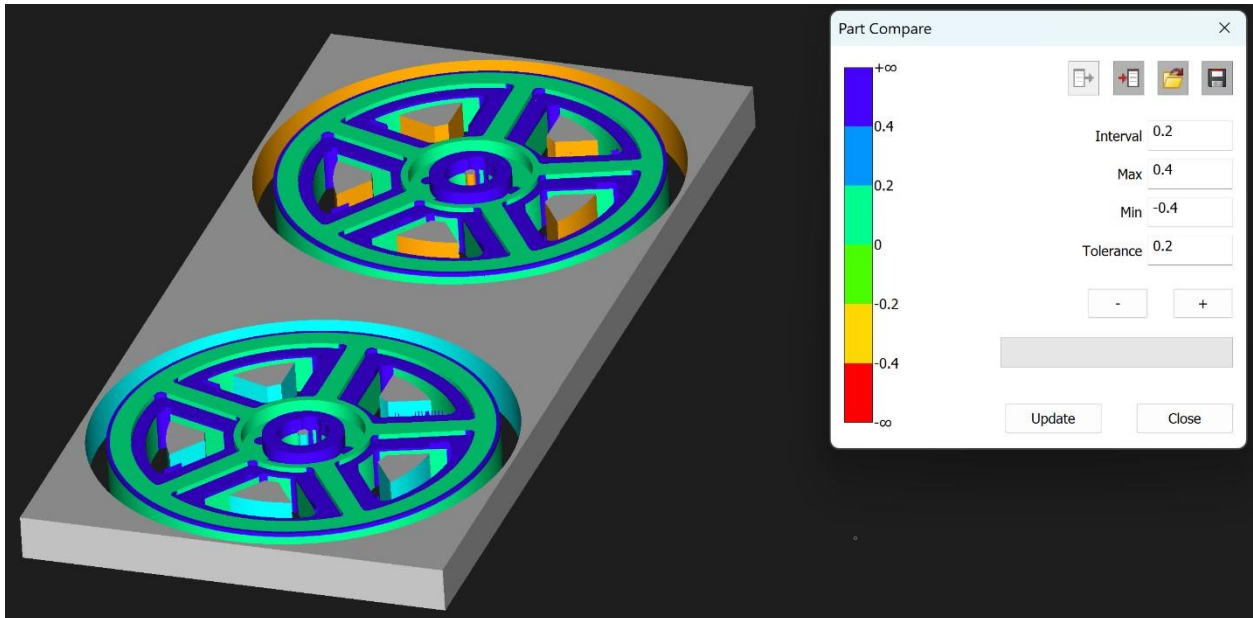

Operations Manager

Operations Manager - Improved Operation Ordering

The manual re-ordering of operations in the **Operations** project page has been modified to remove restrictions that prevented an Operation being moved into another Operation Group if that group was using a different Tool. The user now has full control over Operation ordering using the **Move Up** and **Move Down** buttons in the toolbar.

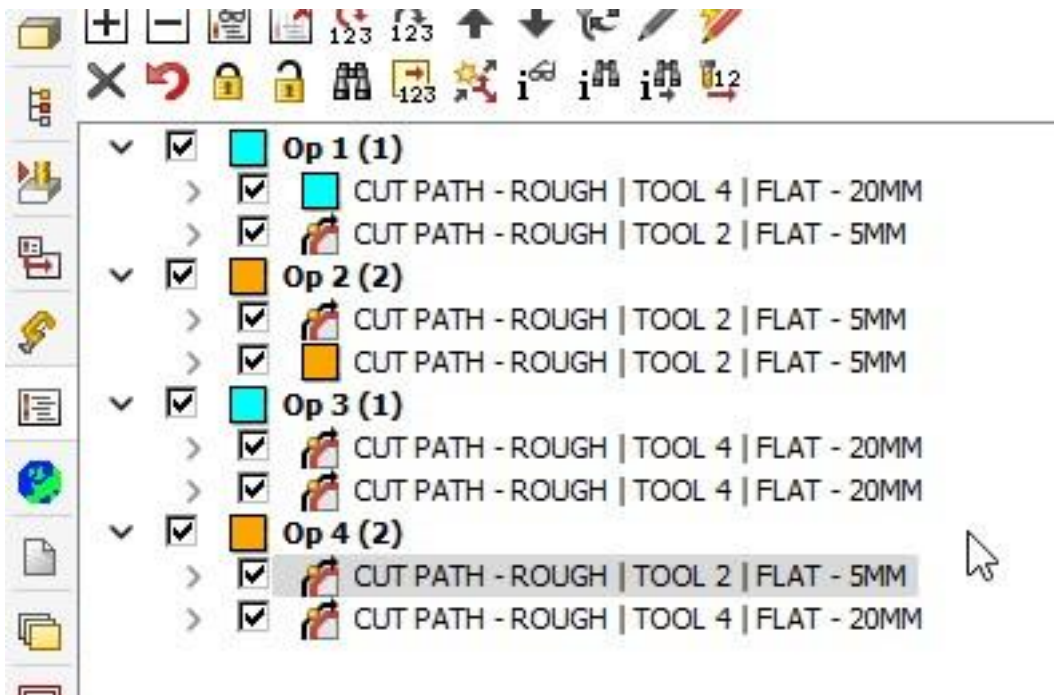

Operations Manager - Ability to rename Operations

As an improvement to workflow, **Operations** can now be renamed in the Operation Tree of the Project Manager using the right-click **Rename** option or by selecting an operation and pressing the **F2** key:

- When an operation is renamed, the Operations text label is replaced with an edit box containing just the renameable part of the text.
- The new name will be saved with the operation and will appear in the first part of the text label for the operation. The tool number and name will always be appended to the custom name.
- If multiple operations are selected, the edit box will appear on the first selected operation, but the changes will be applied to all selected operations.

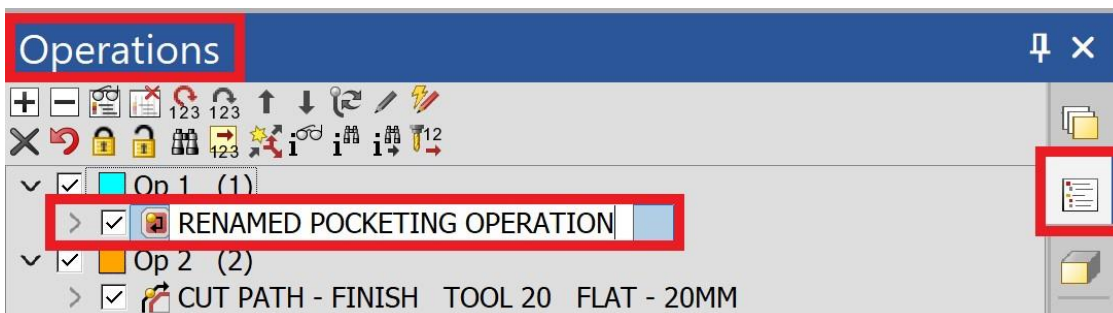

Operations Manager - Ability to rename Operation Groups

As a further improvement to workflow, **Operation Groups** can now be renamed in the Operation Tree of the Project Manager using the right-click **Add/Edit Comment** option or by selecting an Operation Group and pressing the **F2** key:

- If multiple operation groups are selected, an edit box will appear on the first selected operation group, but the changes will be applied to all selected operation groups.
- There is a change to the appearance of the Operation Group text as they are now rendered in bold whether they have an optional comment applied or not.
- The operation group comment will appear in the operation list summary when doing NC Output. It will appear first, before the list of sub-operations.

i

When nesting, Operation Group names in nest parts may not be preserved.

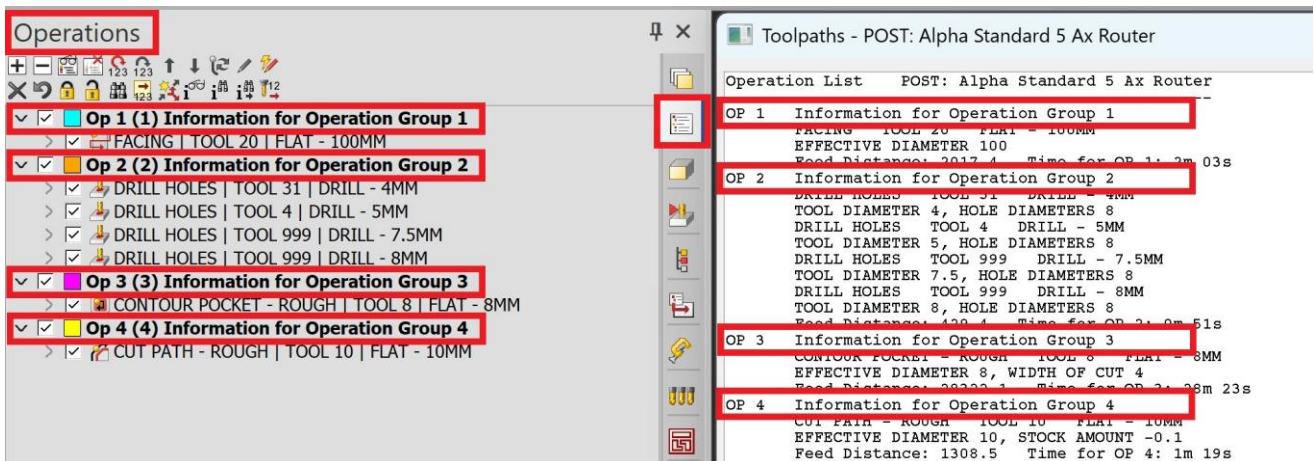

The screenshot displays the 'Operations' tree on the left and the 'Toolpaths - POST: Alpha Standard 5 Ax Router' list on the right. Red boxes highlight the operation group names in both views.

Operations Tree (Left):

- Op 1 (1) Information for Operation Group 1
 - FACING | TOOL 20 | FLAT - 100MM
- Op 2 (2) Information for Operation Group 2
 - DRILL HOLES | TOOL 31 | DRILL - 4MM
 - DRILL HOLES | TOOL 4 | DRILL - 5MM
 - DRILL HOLES | TOOL 999 | DRILL - 7.5MM
 - DRILL HOLES | TOOL 999 | DRILL - 8MM
- Op 3 (3) Information for Operation Group 3
 - CONTOUR POCKET - ROUGH | TOOL 8 | FLAT - 8MM
- Op 4 (4) Information for Operation Group 4
 - CUT PATH - ROUGH | TOOL 10 | FLAT - 10MM

Toolpaths - POST: Alpha Standard 5 Ax Router (Right):

```

Operation List      POST: Alpha Standard 5 Ax Router
OP 1  Information for Operation Group 1
      FACING TOOL 20 FLAT - 100MM
      EFFECTIVE DIAMETER 100
      Feed Distance: 2017.4 Time for OP 1: 2m 03s
OP 2  Information for Operation Group 2
      DRILL HOLES TOOL 31 DRILL - 4MM
      TOOL DIAMETER 4, HOLE DIAMETERS 8
      DRILL HOLES TOOL 4 DRILL - 5MM
      TOOL DIAMETER 5, HOLE DIAMETERS 8
      DRILL HOLES TOOL 999 DRILL - 7.5MM
      TOOL DIAMETER 7.5, HOLE DIAMETERS 8
      DRILL HOLES TOOL 999 DRILL - 8MM
      TOOL DIAMETER 8, HOLE DIAMETERS 8
      Feed Distance: 420.4 Time for OP 2: 0m 51s
OP 3  Information for Operation Group 3
      CONTOUR POCKET - ROUGH TOOL 8 FLAT - 8MM
      EFFECTIVE DIAMETER 8, WIDTH OF CUT 4
      Feed Distance: 20222.1 Time for OP 3: 28m 23s
OP 4  Information for Operation Group 4
      CUT PATH - ROUGH TOOL 10 FLAT - 10MM
      EFFECTIVE DIAMETER 10, STOCK AMOUNT -0.1
      Feed Distance: 1308.5 Time for OP 4: 1m 19s
  
```

Operations Manager - Vertical bar delimiter for Operations

As a general improvement to the Operations tree in the Project Manager, the **Operation Name**, **Tool Number** and **Tool Name** fields are now separated by a vertical bar separator instead of white space.

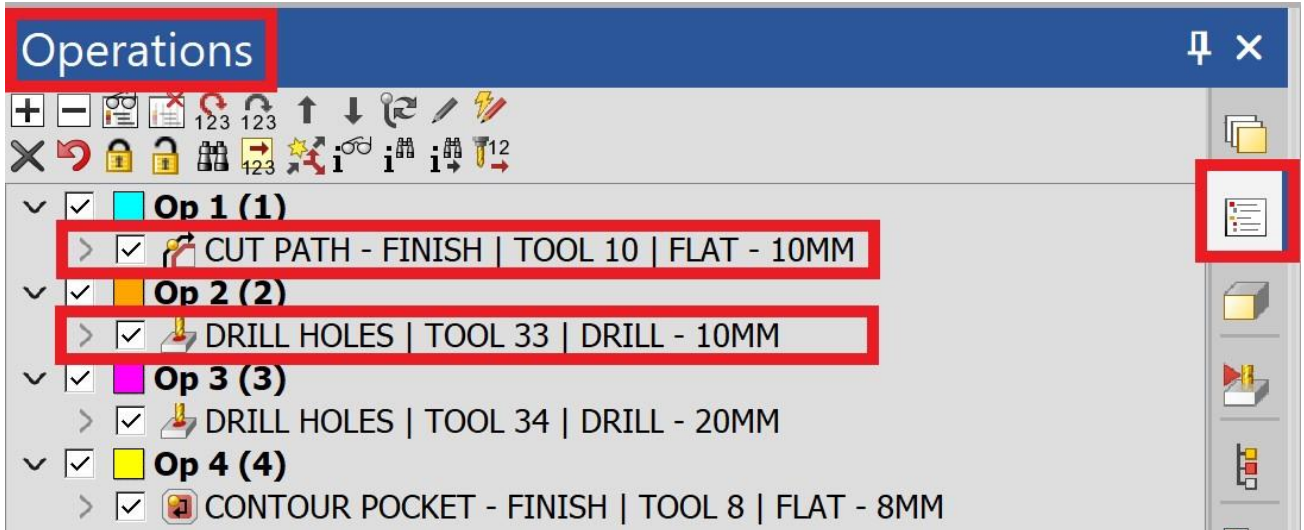

Operations Manager – Improved Geometry Selection

As an improvement to the Operations Manager, the options have been renamed in the shortcut menu that appears when you right-click-on these items:

- Geometries
- Guide Curves
- Boundaries
- Foul Avoidance (for Sawing operations)

For example, the **Add Geometry** and **Add Boundary** options have been renamed to **Add/Remove Geometry** and **Add/Remove Boundary**. ALPHACAM now shows the existing items as pre-selected in the Drawing area. To add or remove items, you can toggle the selection state. Once finished, the 2D operations immediately regenerate and use the new items. If nothing has changed in the selection, the operation won't be updated.

	<p>For 3D Machining cycles, the operation is flagged that requires an update because it is not updated automatically.</p>
---	---

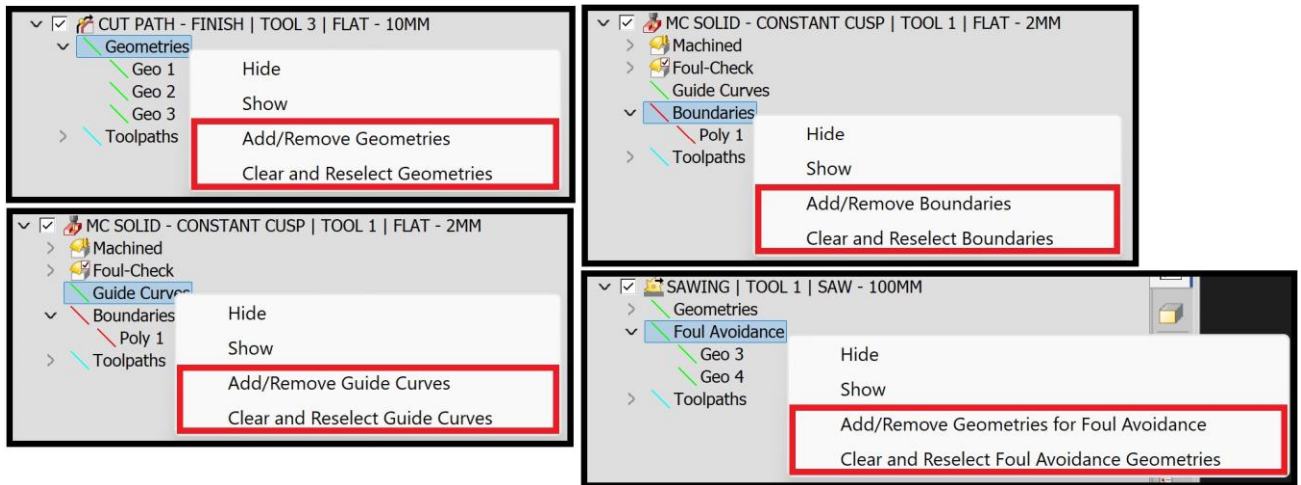

Operations - Improved selection of 3D Machining Entities

As an improvement to the Operations Manager for 3D machining of Solids, Surfaces, Solid Model Faces and Splines, the options have been renamed in the shortcut menu that appears when you right-click-on these items:

- Machined Solids
- Machined Surfaces
- Foul Check Solids
- Foul Check Surfaces
- Splines

For example, the **Add Solids** and **Add Surfaces** options have been renamed to **Add/Remove Solids** and **Add/Remove Surfaces**. ALPHACAM now shows the existing items as pre-selected in the Drawing area. To add or remove items, you can toggle the selection state. The **Clear and Reselect** menu options have been added for entity types too. Once finished, the 2D operations (for example, Cut Path, Sawing, Drilling and Chamfering) immediately regenerate and use the new items.

	<p>For 3D Machining cycles, the operation is flagged that requires an update because it is not updated automatically.</p>
--	---

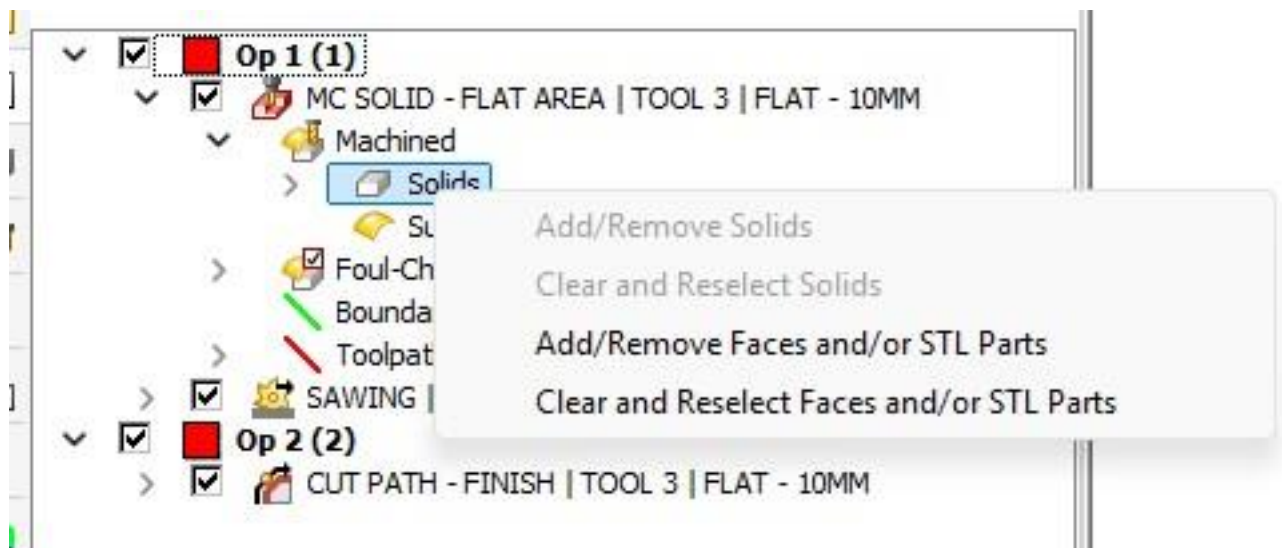

Operations - Cut Between 2 Geometries – Clear and Reselect Geometries

In Operations Manager for Cut Between 2 Geometries, the **Clear and Reselect Geometries** option has been added to the right-click context menu of the Geometries node within an operation.

The user is prompted to select the programming and auxiliary geometries, and the cycle updates automatically.

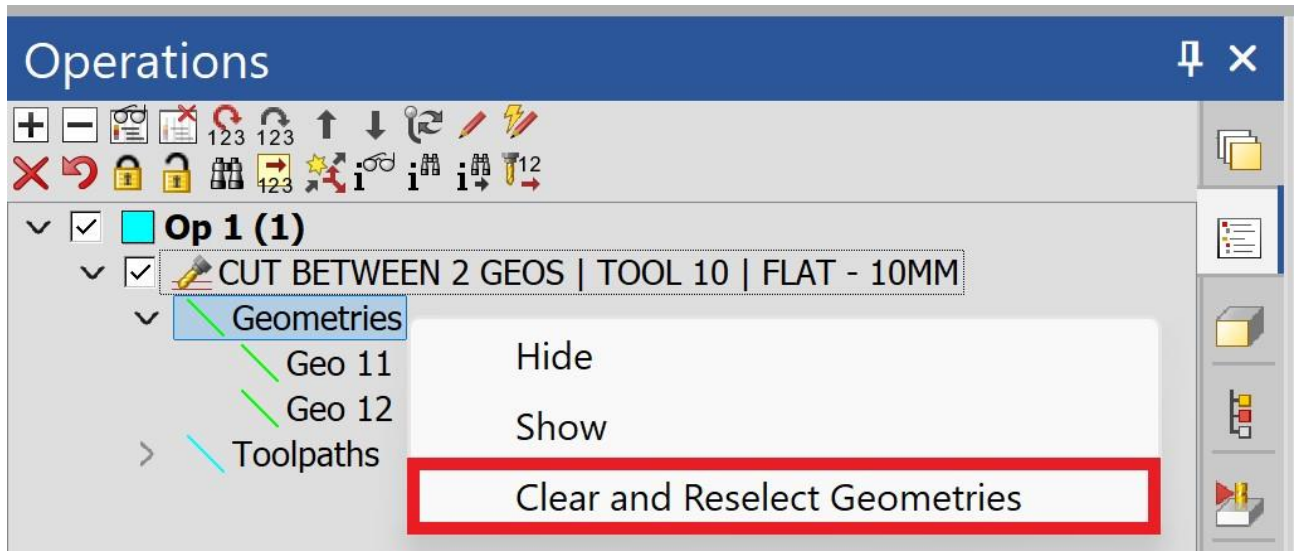

Operations Tab

Operations Tab - Multi selected items - Space Bar support to toggle visibility

In the Operations page of the Project Manager, spacebar now supports toggling the visibility of multiple selected Operation Groups or Operations.

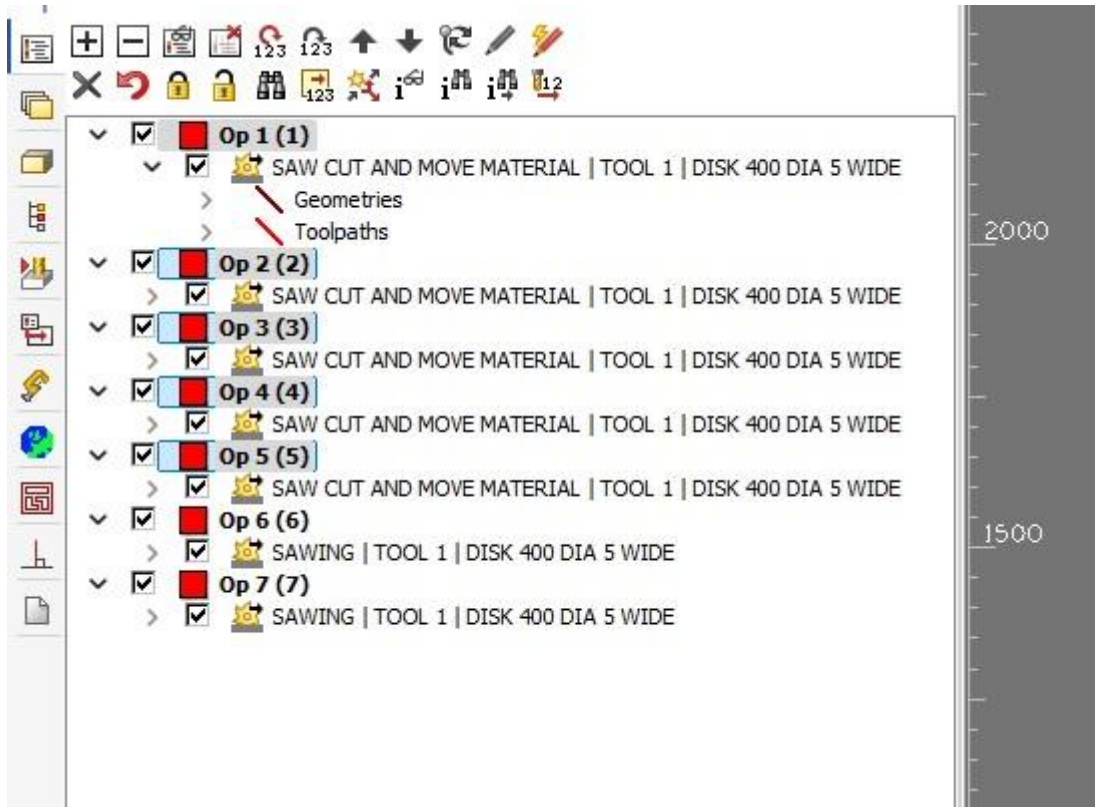

Styles - Auto-Z Drilling - Show Maximum Depth of Tool Dialog

As an improvement when applying Auto Z Drilling styles, the **Maximum Depth of Tool would be exceeded** dialog now appears to select either the **Use Full Depth** or **Use Depth Defined for Tool** option.

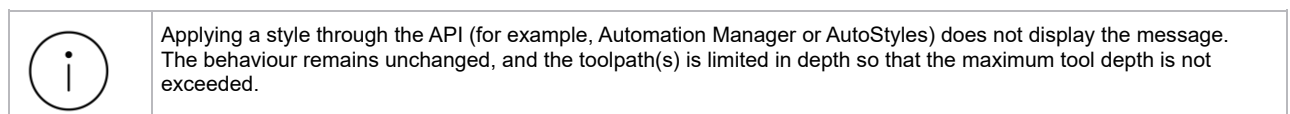

Layers Manager

Layers Manager - Support renaming of Text, Surfaces and Splines

As an improvement to the Project Manager, it is now possible to rename Text, Surfaces and Splines from both the UI and via the API. Name changes are undoable and will mark the drawing as modified.

A **Rename** option has been added to the right-click context menu for Text, Splines and Surfaces.

The ability to rename by pressing the **F2** key has now been added to the following areas:

- Layer Manager - Geometry, Construction, Toolpaths, Solid Model, STL, Text, Splines, Surfaces.
- Work Plane contents (excluding Surfaces, STL and Solid Models).
- User Layers contents.
- Operations.

Automation Manager

Automation Manager - Default Settings - Option to hide UI tabs

A new **Interface Display Options** node has been added within the **Default Settings** tab which contains **Extended Functionality** and **Core Ribbons** sections. Here, the user can toggle the visibility of certain functionality on or off to create a more streamlined user interface. Whether a feature is hidden or not, the functionality remains the same.

Extended Functionality

When the checkbox is unchecked, the corresponding tab and any settings are hidden from the Automation Manager UI.

Multidrill:

- Multidrill tab.
- Configuration - Main Settings - Multidrill Head.

Machining Order:

- Machine Order tab.
- Processing - Job Files.
- Processing - Job/CDM Job - Main Settings.
- Configuration - Job File Defaults.
- Default Settings - Job Defaults.

Import Settings:

- Import Settings tab.
- Processing tab - Processing Ribbon - Import Data group.
- Processing tab – Right-click context menu (Middle tree) - Import Files Into Job.

Core Ribbons

When the checkbox is unchecked, the corresponding tab is hidden from the Automation Manager UI but the options are still present in the **Processing** tab as these are required to process jobs:

- Layer Mapping Setup.
- Materials.
- Configuration.

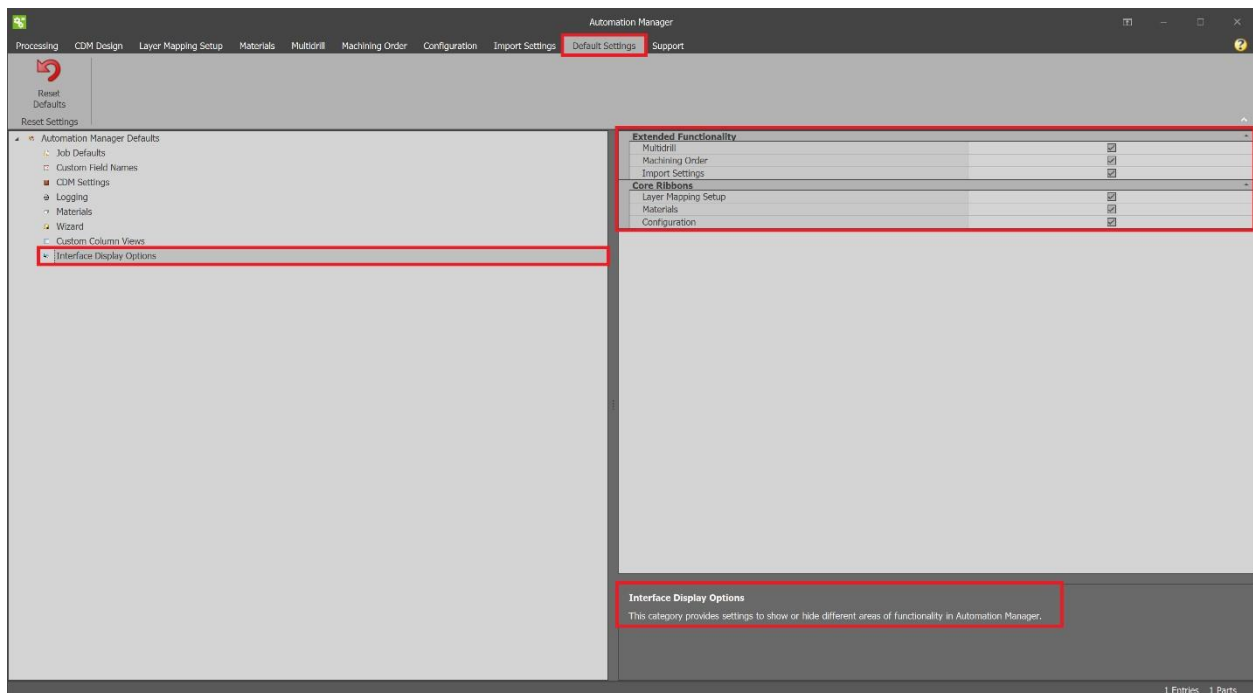

Automation Manager - Move Parts to a New Job when Multiselect Processing

A new **Automatically Create New Job when Multiselecting Parts for Processing** option has been added to the **Special Settings** section of the **Configuration** tab.

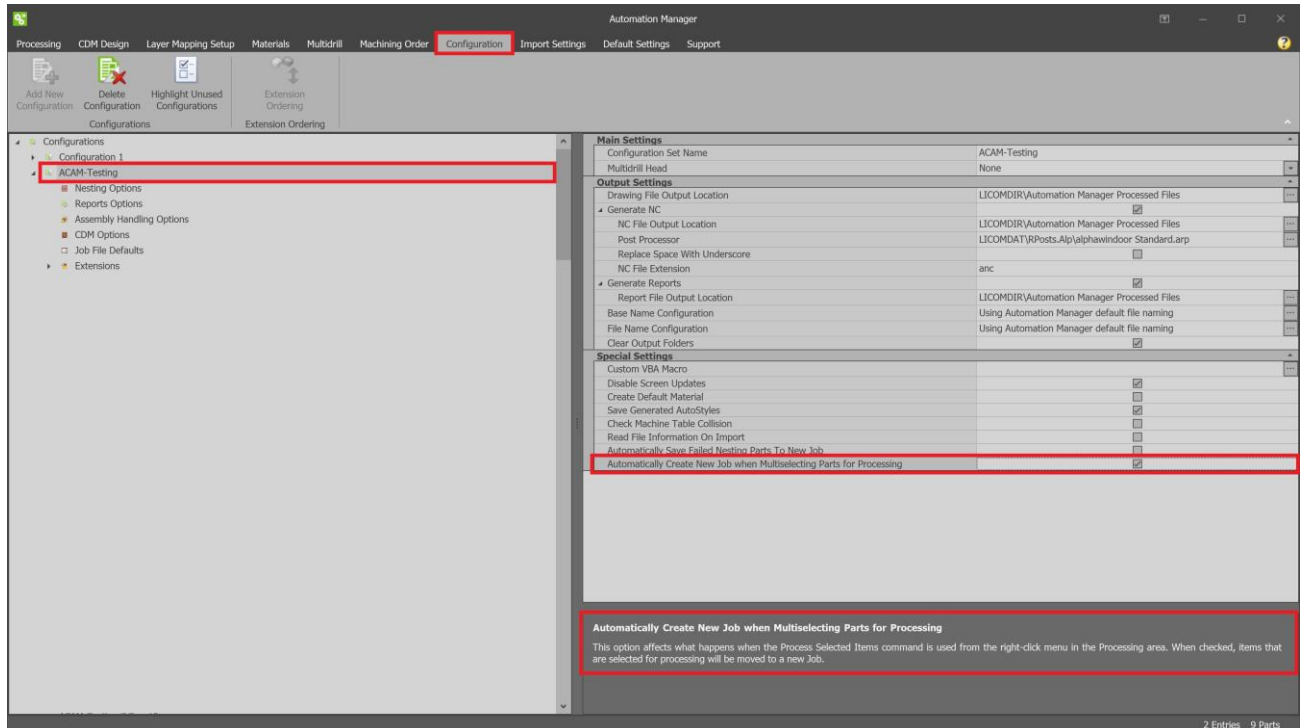

When you select this option and multiselect Job Files or CDM Doors in an Automation Manager or a CDM job and then select the **Process Selected Items** option, all the selected items are processed and moved to a new job. The selected items are also removed from the original job.

The **Move to New Job** option has also been added to the right-click context menu. This option is available when either Automation Manager or CDM job file(s) are selected. The option moves the selected parts to a new job.

The New Job shares all the properties, including customer information of the original job.

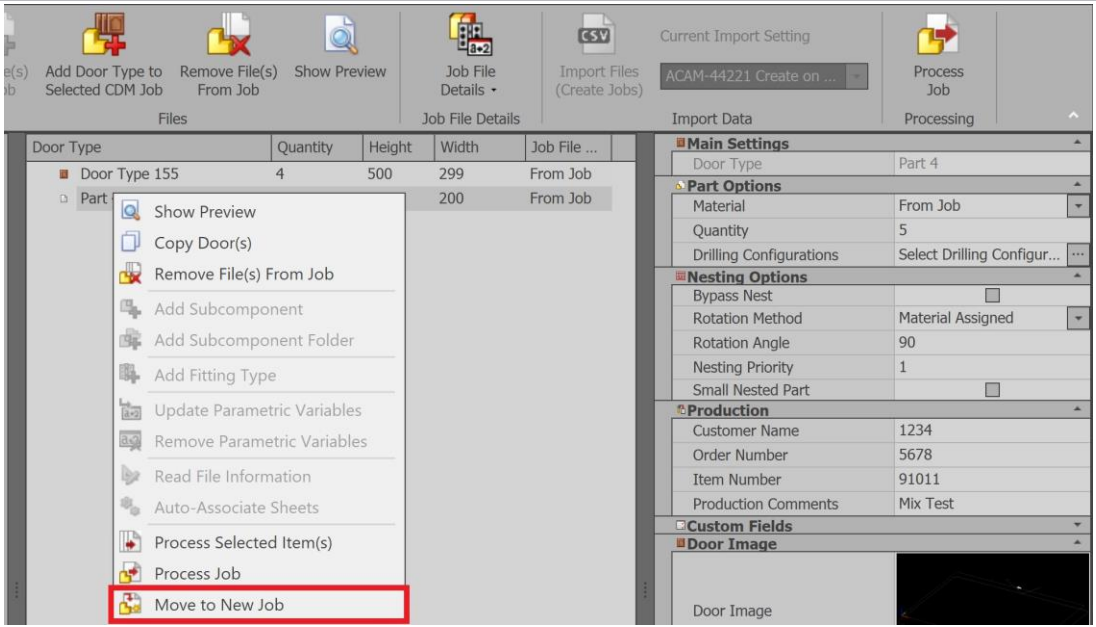
	<ul style="list-style-type: none"> The Move to New Job option does not support Multiple Process jobs. When processing selected items, the processed job name will be given the name of the current job. This may change in a future release of ALPHACAM to indicate that the job only contains some parts.
 <p>The screenshot shows the software interface with a context menu open over a table of items. The table has columns: Door Type, Quantity, Height, Width, and Job File ... The table contains two rows: 'Door Type 155' with Quantity 4, Height 500, Width 299, and 'Part' with Quantity 200, Height 200, Width 200. The context menu includes options like 'Show Preview', 'Copy Door(s)', 'Remove File(s) From Job', 'Add Subcomponent', 'Add Subcomponent Folder', 'Add Fitting Type', 'Update Parametric Variables', 'Remove Parametric Variables', 'Read File Information', 'Auto-Associate Sheets', 'Process Selected Item(s)', 'Process Job', and 'Move to New Job'. The 'Move to New Job' option is highlighted with a red box.</p>	

Automation Manager - Preserve Layers with Duplicated Names

Layer Mapping Setups have been improved and it is now possible to repeat a Layer in a different position within the same setup. This applies when adding **Drawing Layers** manually or importing from a drawing, or the automatic addition of **Feature Extraction Layers**. The **Copy** and **Paste** options within a **Layer Mapping Setup** have also been modified.

In Layer Mapping Setups, it is possible to copy and paste:

- An entire Layer Mapping Setup.
- The Layers (all Layers) of a Setup.
- An individual Layer of a Setup.
- A Machining Style of a Layer Mapping Setup.

Automation Manager and CDM

Automation Manager and CDM - Add functionality to define Small Parts based on dimensions

A new **Automatic Small Part Assignment** category has been added to the **Nesting Options** section of the **Configuration** tab. When the **Use Automatic Small Part Assignment** check box is selected, the following options become available:

- **Small Part X or Y Dimension** – Automation Manager Parts or CDM Parts with an X or Y dimension below the defined value will be designated as a small part.
- **Small Part Area** – Automation Manager Parts or CDM Parts with an area below the defined value will be designated as a small part.

When parts are added to a job using a configuration with **Automatic Small Part Assignment** enabled, any part that meets the criteria will be flagged as a **Small Nested Part** in the **Nested Part Settings** of the part file or CDM door.

If the new **Use Automatic Small Part Assignment** option is activated after the parts have been added to a job, when the job is processed, any parts that meet the criteria will be added to the small part zone on the nested sheet, if defined, but the **Small Nested Part** check box in **Nested Part Settings** will not be updated.

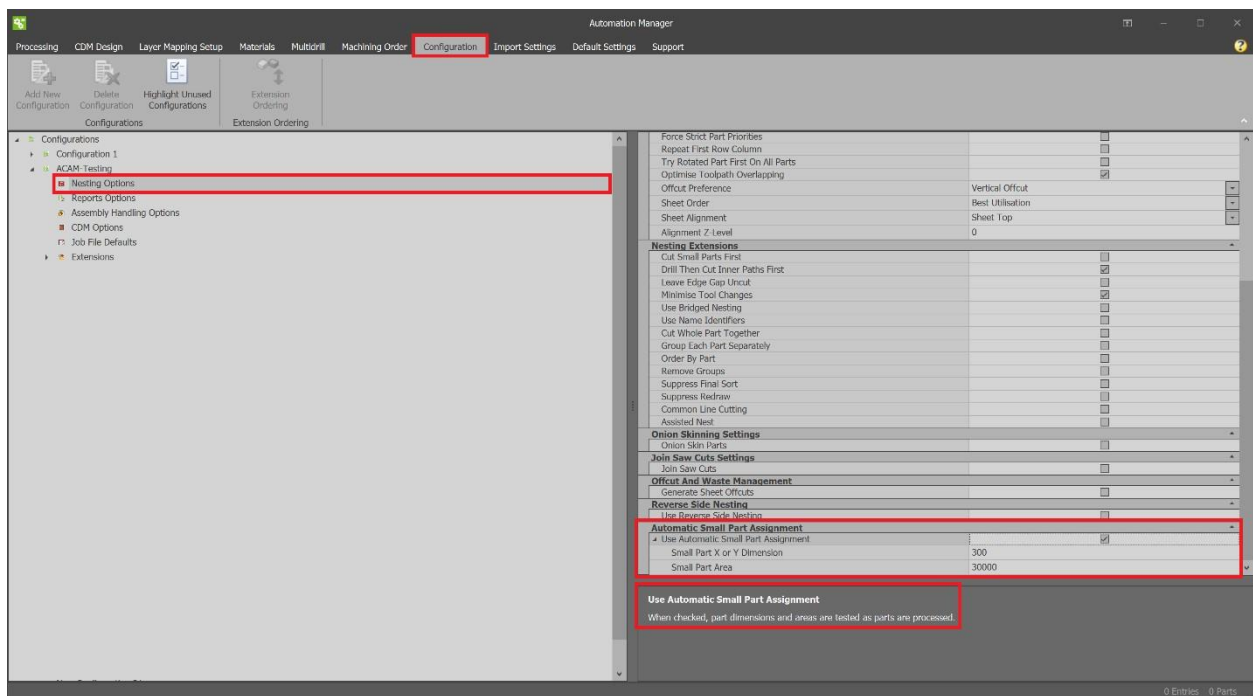

Quick Nest

Quick Nest – Ability to create Nest Lists

The ability to create a Nest List from a Quick Nest Geometry has now been implemented. The initial Quick Nest dialog has been updated to include a new **Nest List Name** field. The **Nest List Name** will use the drawing name if the file has been saved and, for unsaved drawings, a default name will be populated.

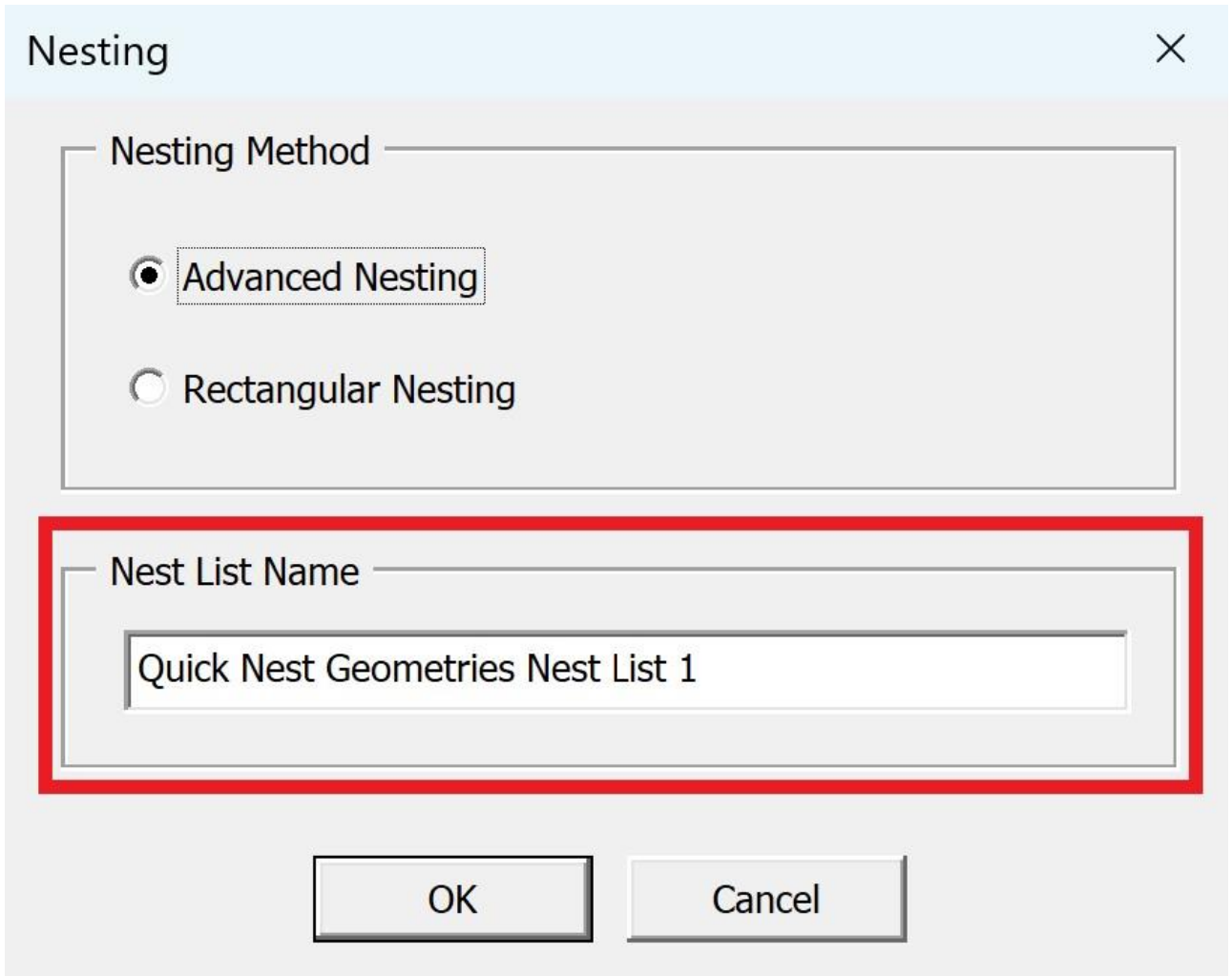

The image shows a screenshot of a software dialog box titled "Nesting". The dialog has a light blue header bar with the title "Nesting" and a close button (X) in the top right corner. The main content area is light gray and contains two sections. The first section, "Nesting Method", has a label and a large rectangular frame containing two radio button options: "Advanced Nesting" (which is selected) and "Rectangular Nesting". The second section, "Nest List Name", is highlighted with a thick red border and contains a text input field with the text "Quick Nest Geometries Nest List 1". At the bottom of the dialog are two buttons: "OK" and "Cancel".

As parts are added to the Quick Nest, the Nest List will be populated with the parts on the nesting tab of the project manager page. The Nest List and the associated parts can then be saved using the **Export NestList and Parts** right-click option within the nesting tab of the Project Manager.

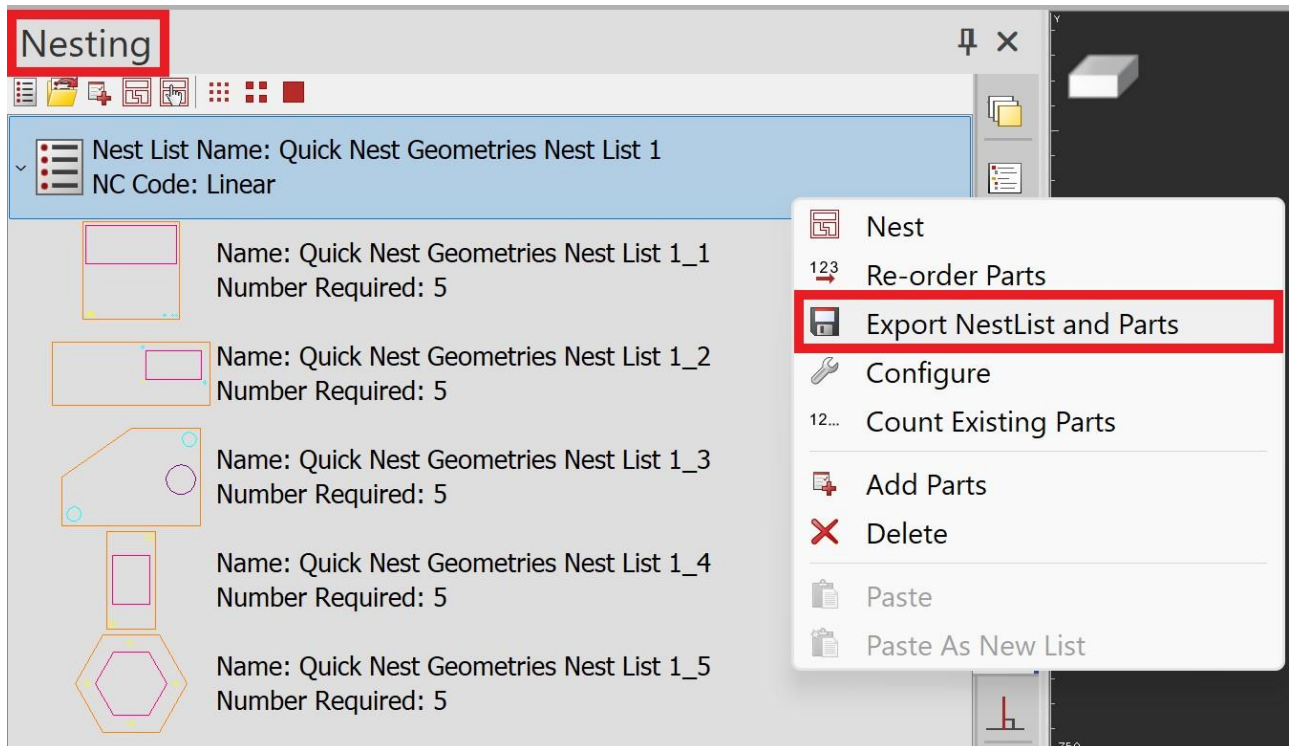

Quick Nest – Toolpaths Support

Quick Nest now supports Toolpaths. It automatically detect Toolpaths and Geometries that make up a Part for Nesting.

There are settings related to Open Path Tolerance that determine how open Toolpaths are detected and associated with a Part.



This is a new feature that is still under development. Sawing toolpaths are currently not supported.

Quick Nest also includes a **Preview** button that highlights the found parts in the selection with an orange outline. This allows you to verify your selection and ensure that Quick Nest has correctly detected the Parts and associated Toolpaths before you proceed to Nesting.



Since the add-in has been renamed from **Quick Nest Geometries** to **Quick Nest**, a manual activation is required. To reactivate it, select **Add-Ins/Macros > Add-Ins Manager**.

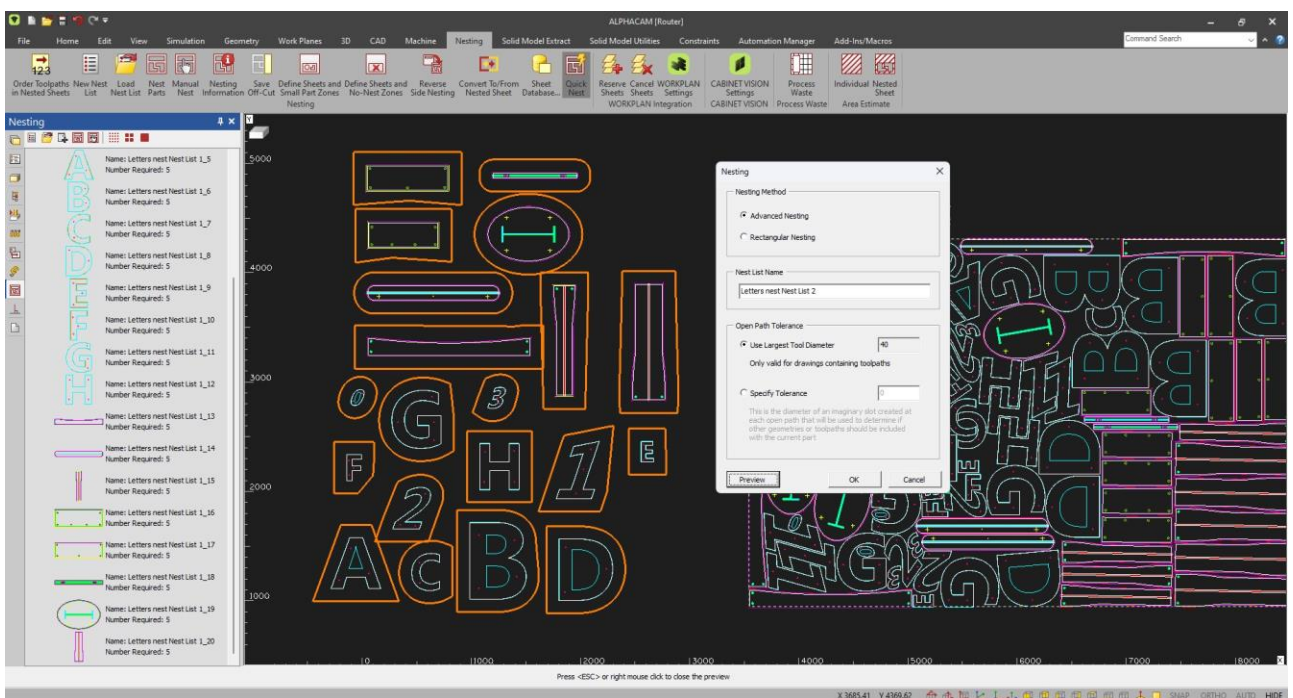



General

Hexagon Universal Updater and new Installer

The Hexagon Universal Updater is introduced in ALPHACAM 2025.3 to make it easier to stay up to date with new releases. This update also includes improvements to the installer.

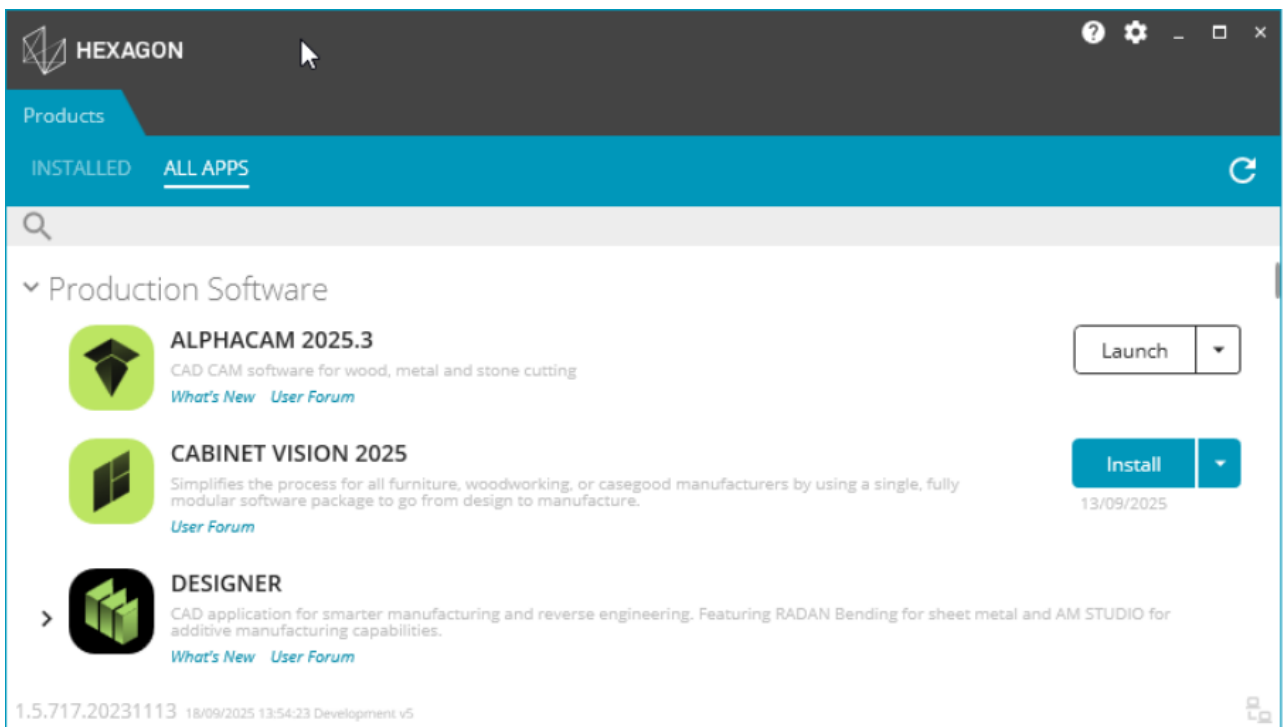
The Universal Updater is installed alongside ALPHACAM. It allows you to quickly check the latest available versions and install updates. It also provides direct links to the online What's New documentation and User Forums for additional support and information.



	<p>Installer files are automatically saved to C:\ProgramData\Hexagon\Universal Updater\DownloadCache.</p>
---	---

Changes to the Installer

The ALPHACAM installer now consists of only three files: the installer executable and two .bin files.

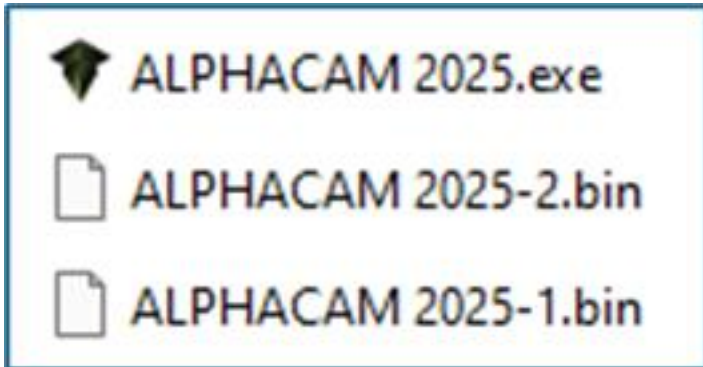

New Options

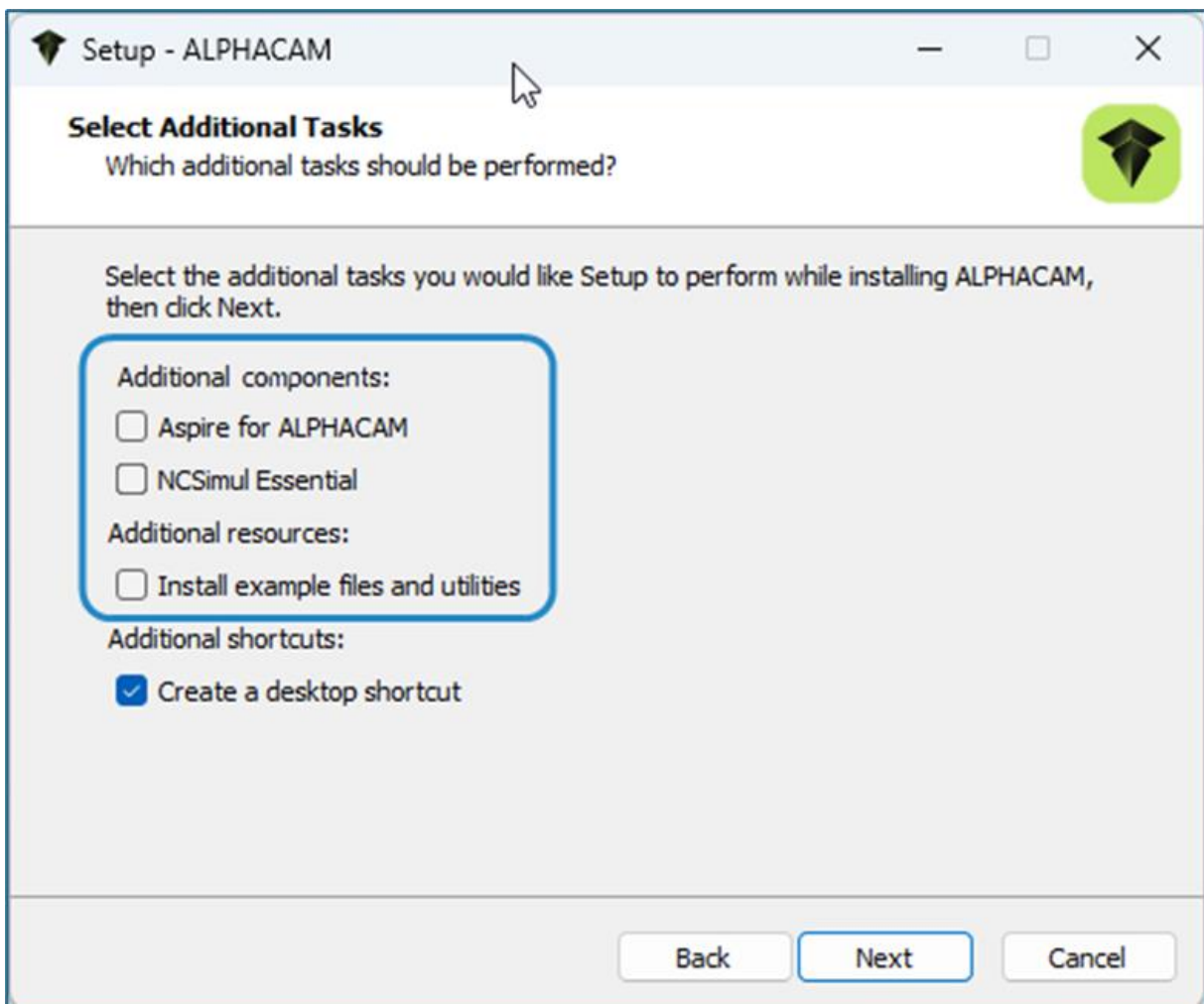

Additional Components:

- Aspire for ALPHACAM
- NCSIMUL Essential

Installing **NCSIMUL Essential** enables the Send to Simulator command in ALPHACAM, that allows simulation with the external NCSIMUL Essential application.

The installation is now optional, as the focus for simulation has shifted to ALPHACAM's internal simulation.

Additional Resources

- Install example files and utilities

Enabling this option unpacks all the useful files that were previously included in the installation package but are not part of the core ALPHACAM installation.

In addition to the usual files, the standard LICOMDAT and LICOMDIR folders (with their contents) are also added for reference. This provides a way to verify and access any missing or updated files from the current standard file set.

When enabled, you are presented with a default location path, which can be modified if required.

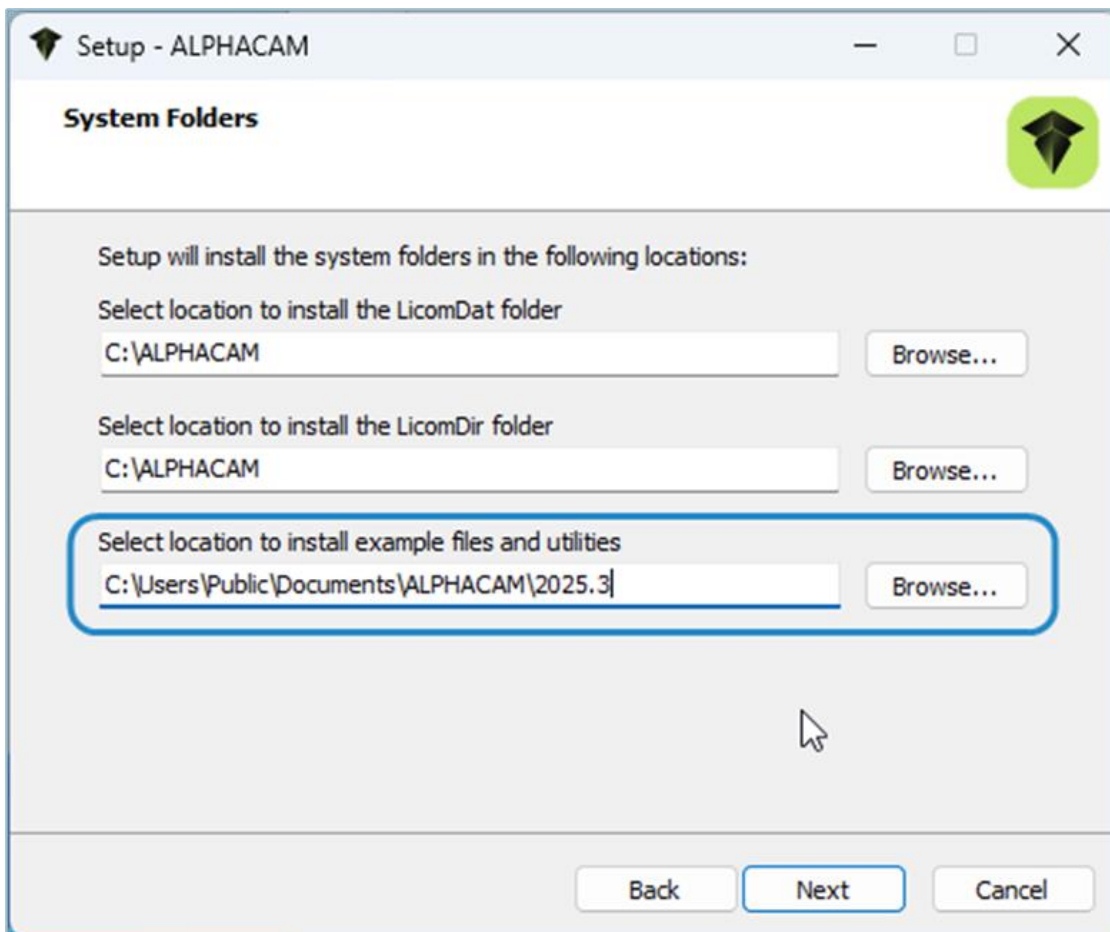

Installer – Warning about Microsoft Windows 10

Added a warning that appears during installation if ALPHACAM 2025.3 is installed on a computer running Microsoft Windows 10, as Microsoft no longer supports this operating system.



Release Notes 2025.2

Maintenance Report

The following is a list of bug fixes and enhancements implemented in ALPHACAM 2025.2:

ID	Description	Closing Notes
28386	Z Contour Roughing - Max Plunge depth on Entry settings does not appear to have any effect.	Fixed.
33444	Edit - Array - If dimensions are included in the Array, extras are created.	Fixed.
37798	Automation Manager - CV Materials Library - Alert User if database configuration file is missing.	Fixed.
42206	Nesting - Selection of Parts - Grouped Toolpaths not being selected correctly.	Fixed.
42288	Automation Manager - Layer Mapping – Multi-select delete styles.	Implemented.
42475	API - Hatching - Hatched Paths are always created on the Active Drawing.	Fixed.
42613	Solid Simulation - Material transfer happens too many times.	Fixed.
43299	Portuguese Language update.	Implemented.
43302	Solid Simulation - Move Material - Clamps and Material not synced.	Fixed.
43322	Simulation - Quickshade Simulation much slower at full speed than 2024.4.	Improved.
43361	Reports - Sample Scripting Report contains error.	Fixed.
43362	Automation Manager - Alphabetical Ordering - Copied Jobs are not ordered correctly when Alphabetical sorting is active.	Fixed.
43431	Simulation - Operation by Operation in old simulator no longer works in 2025.1.	Fixed.
43496	Solid Simulation - Improve Cancel Automatic Material Creation.	Implemented.
43596	ModuleWorks 2024.12 Chinese Traditional Resource DLLs.	Added.
43624	Sheet Database - Materials - Ordering reverts back and user defined order is not remembered.	Fixed.
43625	Automation Manager - Failing to Apply Toolpaths since ACAM-39571 when xPositional is not Present.	Fixed.
43648	NestPart.PlacePart crashes or fails to place the part.	Fixed.
43784	Update SolidLink 2025.2.	Implemented.
43785	Update NCSIMUL 2025.2.	Implemented.
43898	Update Parasolid to v37.0.185.1.	Implemented.
44110	Reports - Filled Colour in Reports does not populate Duplicate Part Pictures.	Fixed.

Whats New

Lathe

Lathe - Part off Cycle - Pick Buttons Added

A further enhancement has been made to the **Part-Off** cycle. It is now possible to pick the Z and Diameter levels from the drawing using the newly implemented **Pick buttons (...)** located next to each manual entry box.

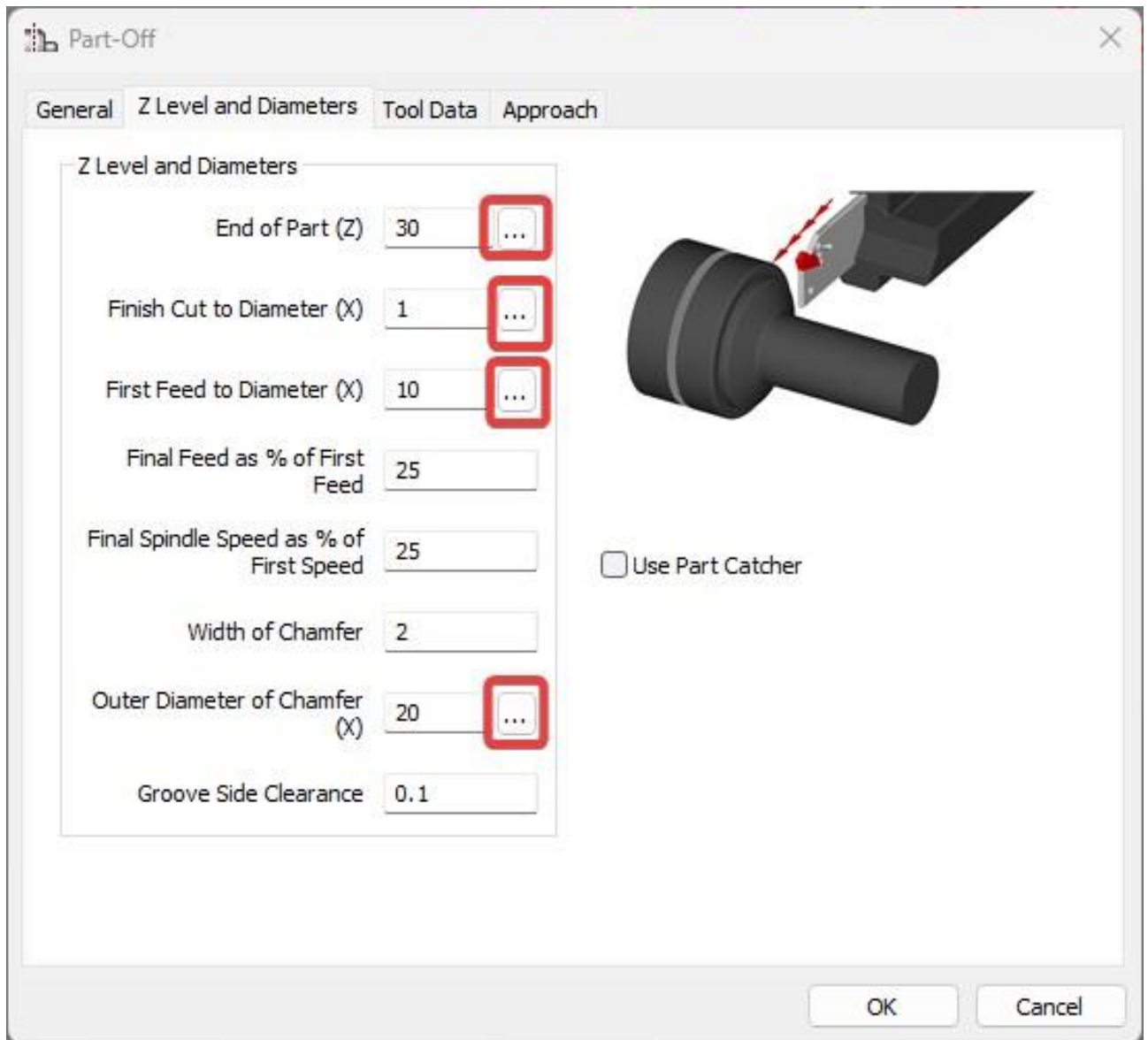

Lathe - Facing - Pick Button Added

A further enhancement has been made to the **Facing** cycle. It is now possible to pick the **Diameter** value from the drawing using the newly implemented **Pick button (...)** located next to the manual entry box.

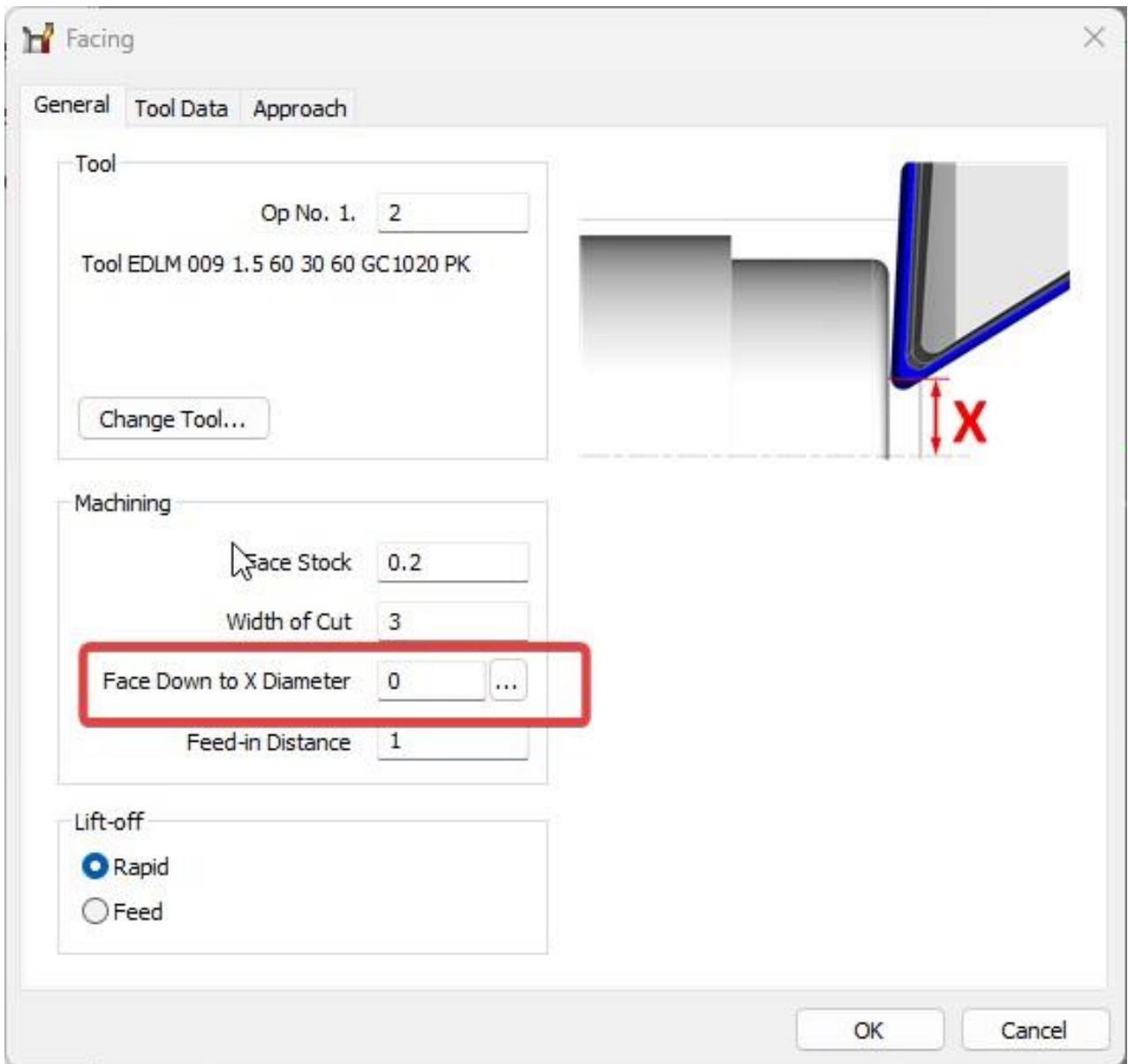

Lathe - Turning Cycles Approach Tab - Pick Button Added

The **Approach** tab of the lathe cycles now allows picking of the Z positioning value from the drawing using the newly implemented **Pick button (...)** located next to the manual entry box.

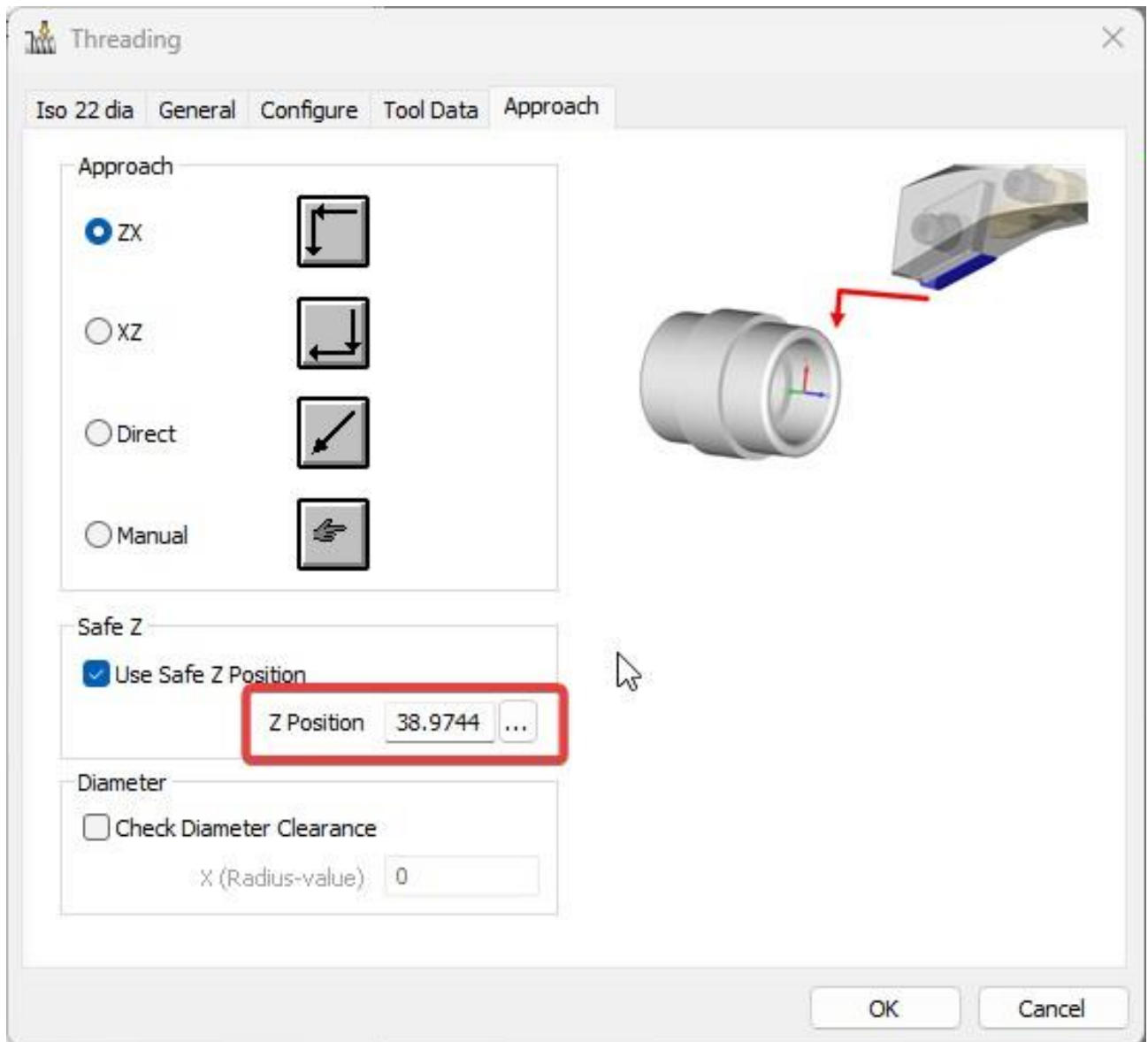

Lathe - Define Tool - Include Coolant options in Lathe Tooling Definition and Editing

The ability to set the **Coolant** options such as **Flood** and **Mist** has been added to the Lathe Tool Definition as seen in Mill, Router or Stone.

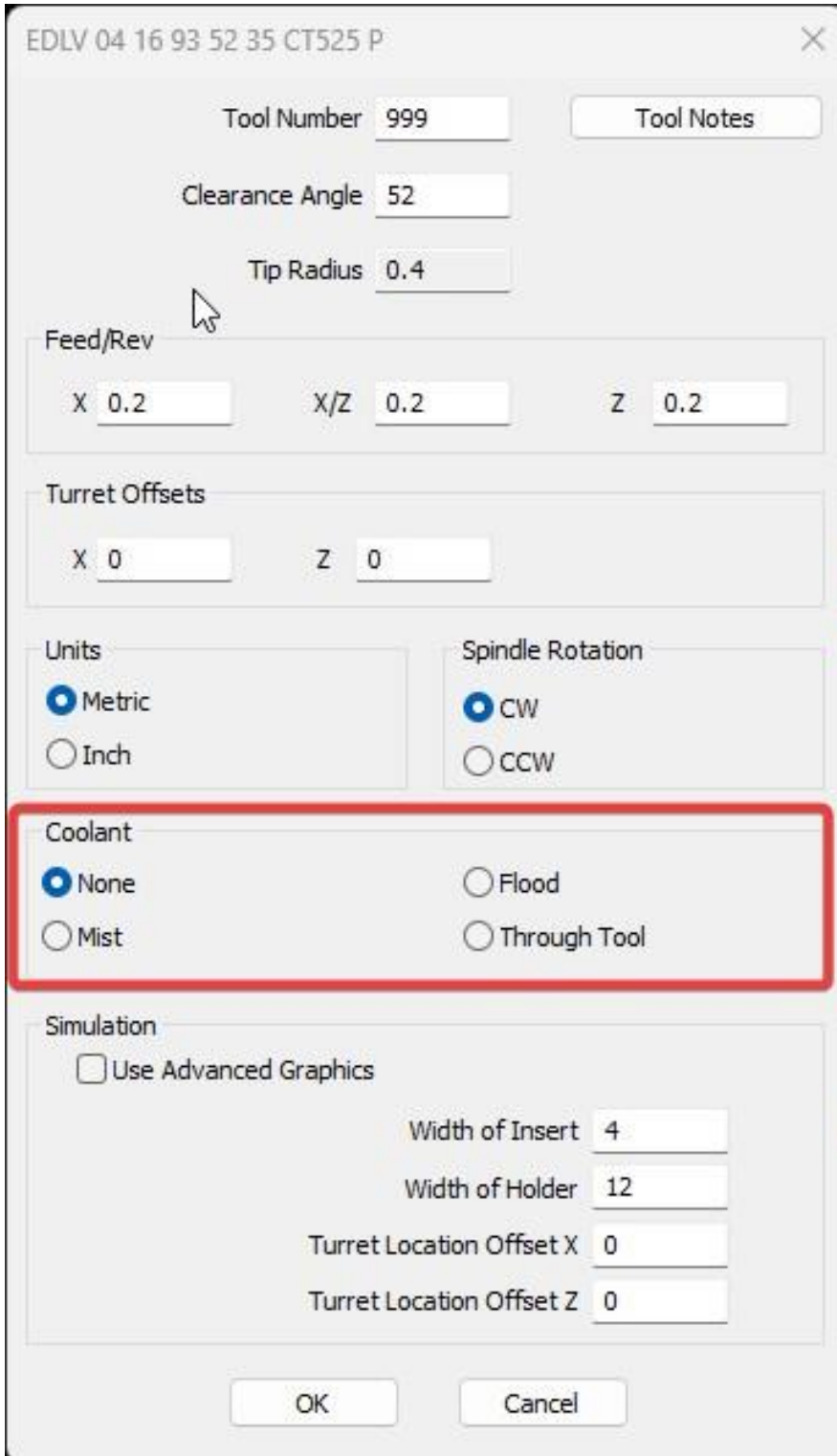

EDLV 04 16 93 52 35 CT525 P

Tool Number

Clearance Angle

Tip Radius

Feed/Rev

X X/Z Z

Turret Offsets

X Z

Units

Metric
 Inch

Spindle Rotation

CW
 CCW

Coolant

None
 Flood
 Mist
 Through Tool

Simulation

Use Advanced Graphics

Width of Insert

Width of Holder

Turret Location Offset X

Turret Location Offset Z

When creating turning Operations, the setting for the coolant is now read from the tool setting:

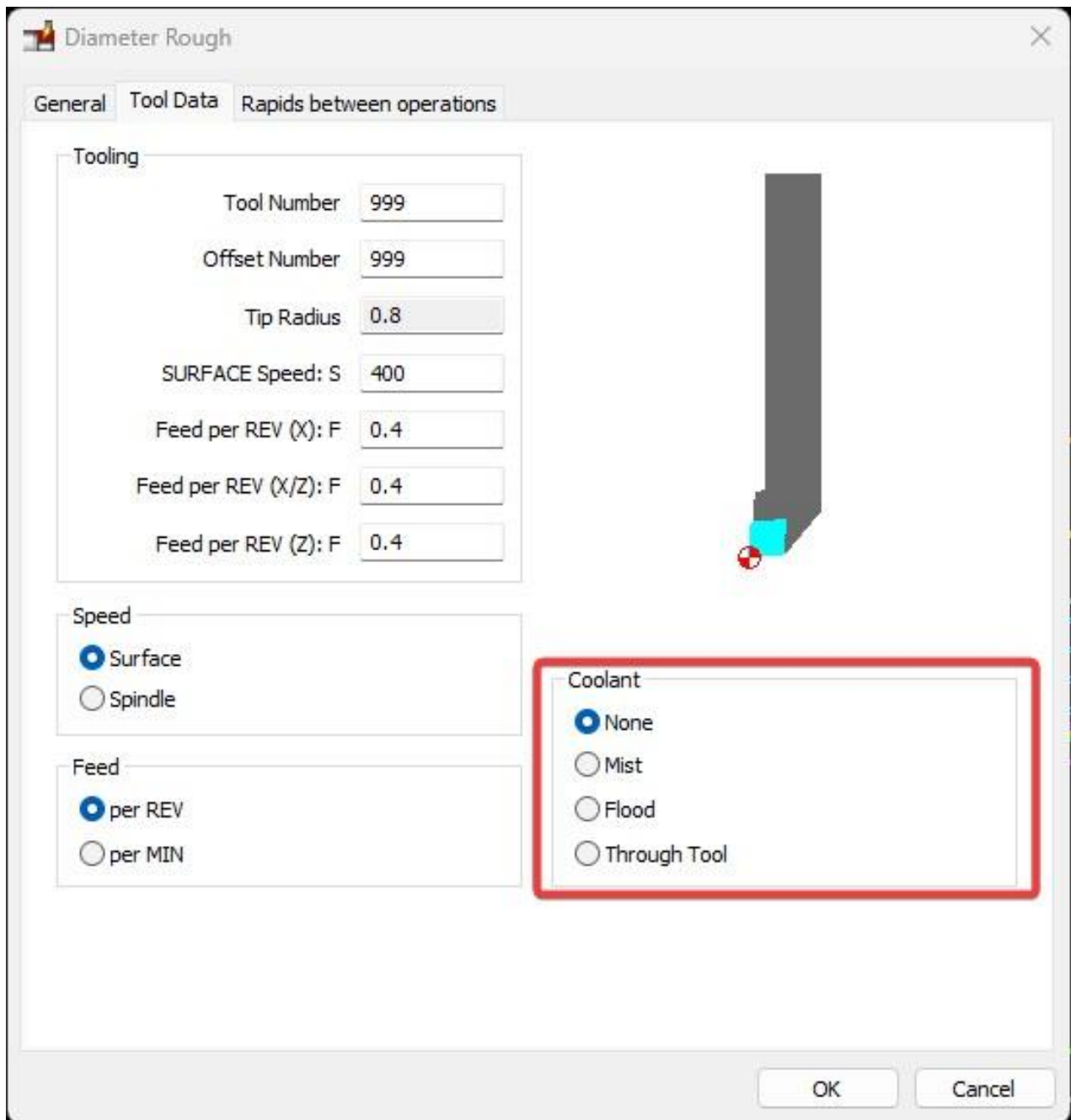

Lathe - Solid Simulation - New Simulator available for preview

If a user turns on the new Solid Simulator in the Lathe module, from the Configuration dialog within the **Simulation** tab of the Project Manager, the following message will be displayed:

The new Lathe simulation feature is currently a work in progress and is available for testing purposes only. Please note that its functionality is not yet complete.

If you have any feedback about the new Solid Simulation, please share it with us via a support case or on the Nexus Community Forums.

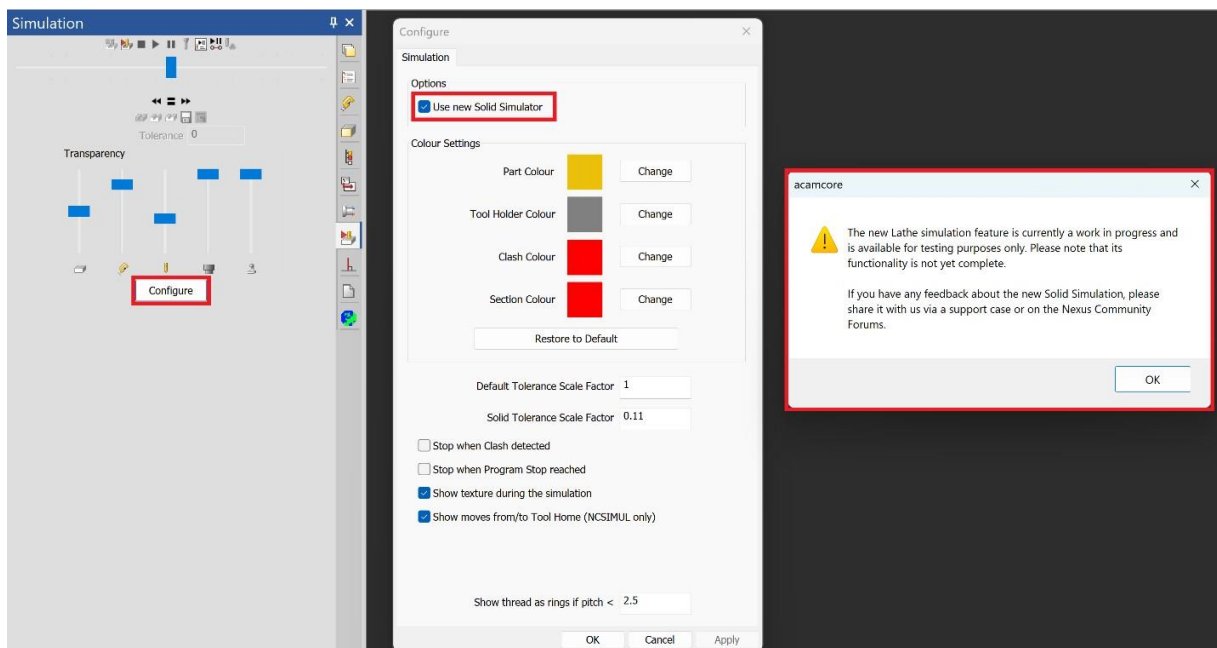

When users attempt to simulate a drawing that contains features that are not yet supported, a warning will be displayed.

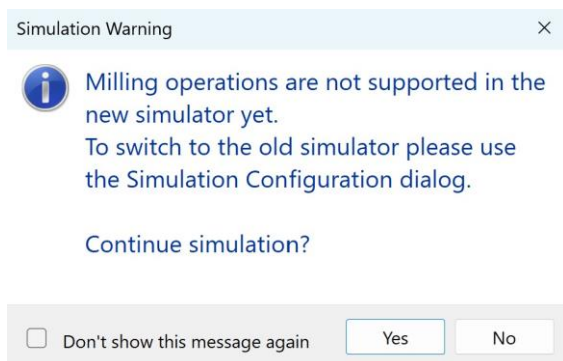

Unsupported features:

- Turret Operations.
- Milling Operations.
- Multi-Channel Machining.

2D Leads

2D Leads - Start and End at Circle Centres

A new **Start and End at Circle Centres** 2D leads option has been added to the **Leads** tab. When selected and applied to a circular toolpath, the centre of that circle is used as the start and end point for the leads. If the toolpath is not a circle, the leads are applied using the other parameters as previously.

The new options are available in 2D operations such as **Cut Path**, **Machine Holes**, and **Chamfering**.

When the new **Start and End at Circle Centres** mode is active on a circular tool path:

- **Line** – Ignores the given line length and angle. A line is added that goes straight to/from circle centre. With an overlap, the lead-in and lead-out will overlap each other.

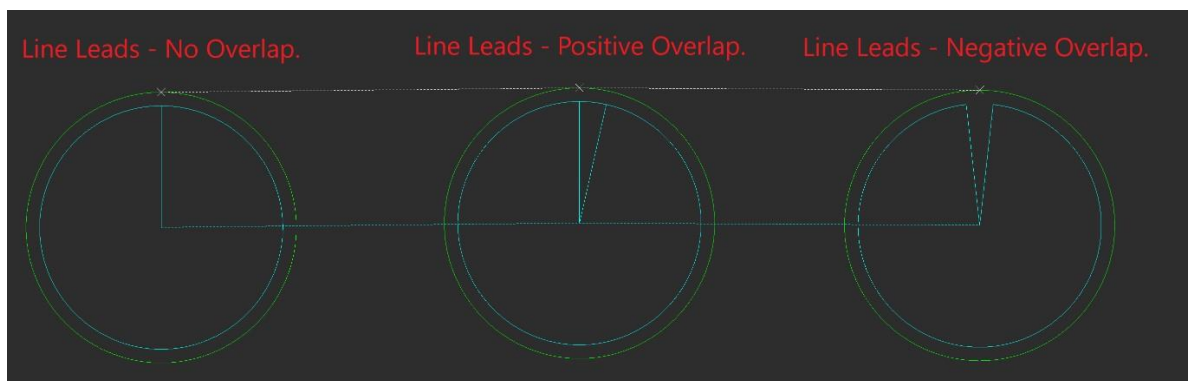

- **Arc** - Ignores radius and direction. A 180 degree arc is added that starts/end at circle centre.

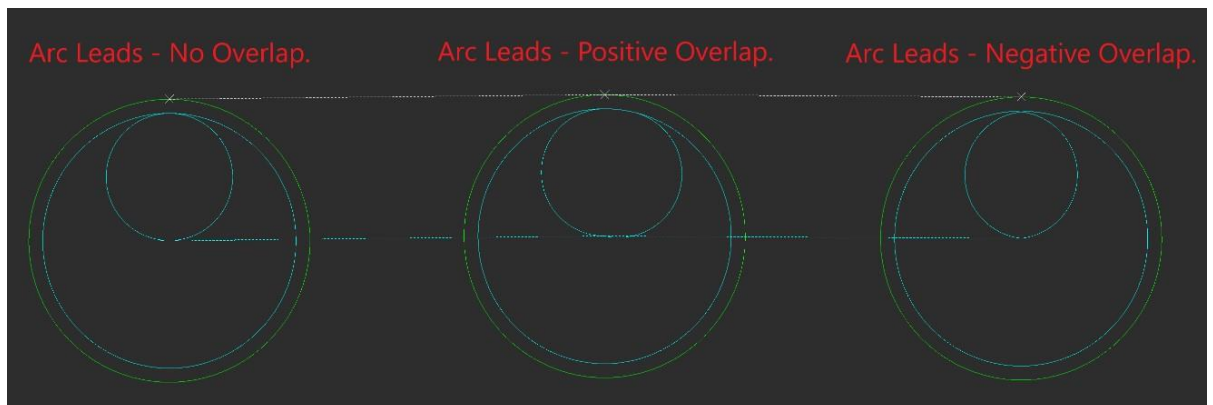

- **Line + Arc not tangential** – Uses the given arc radius to create a 90 degree arc and a line to/from circle centre.

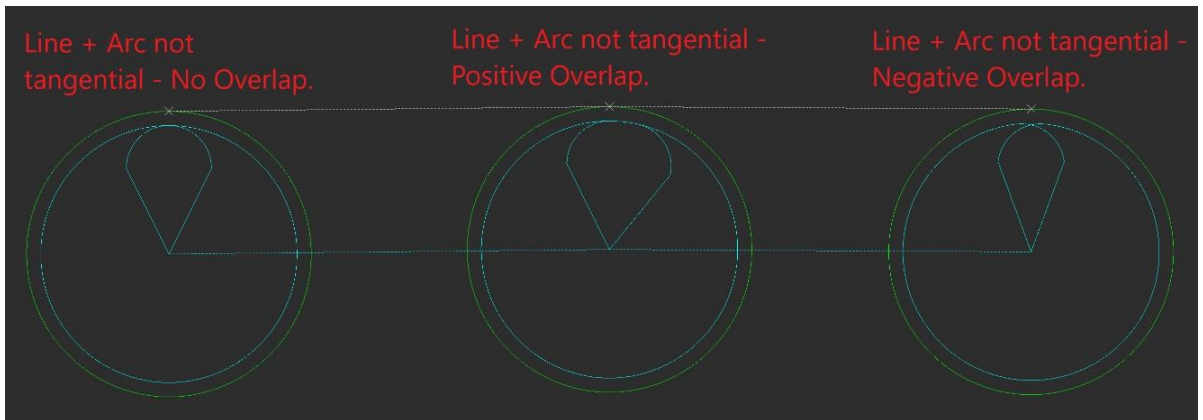

- **Line + Arc tangential** – Uses the given arc radius but ignores line length and angle. If the radius is too big, it will be automatically replaced with a line-only lead. When it fits, only the included angle of the arc is computed which means that the user will see a tangential line to/from circle centre.

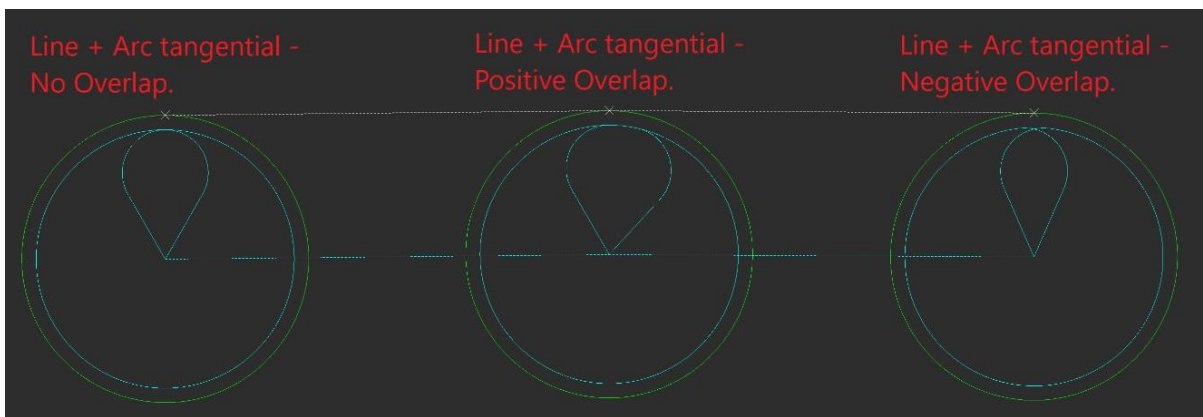

3D Machining

3D Machining - Improved toolpath processing times of large models

3D Machining performance has been improved for complex models which have features outside of the specified Z limits for machining.

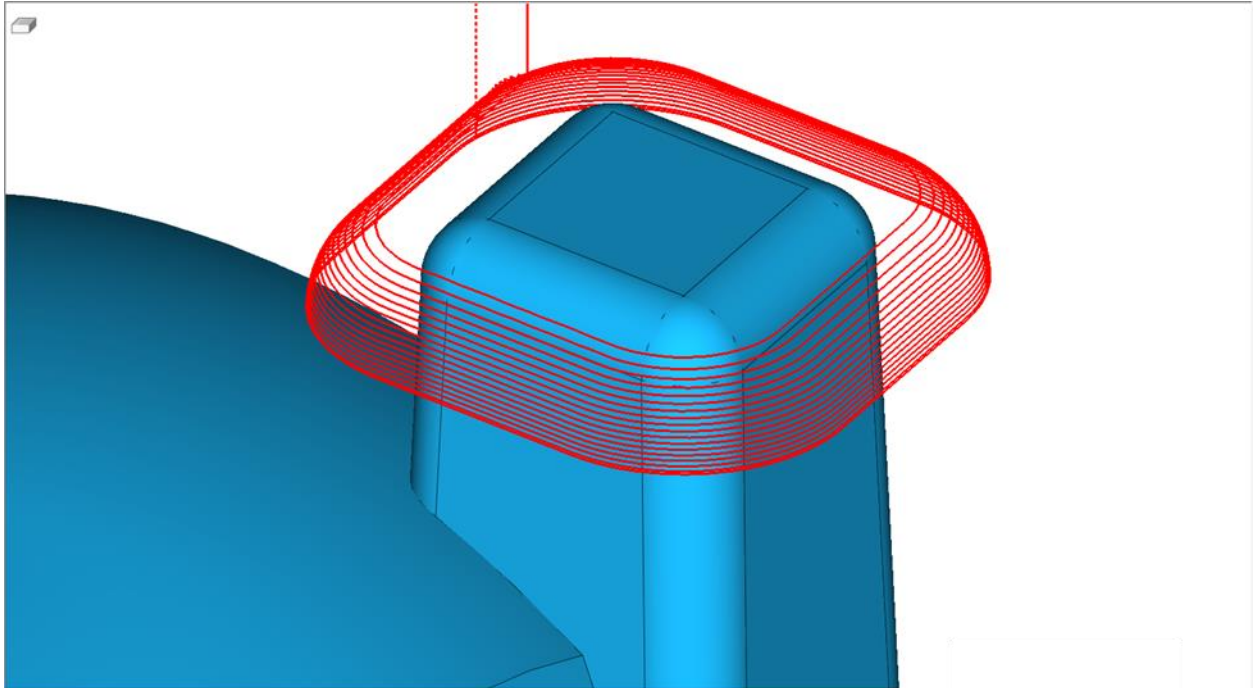

Tool Definition

Tool Definition - New Material Entry Settings - Centre Cutting Tool and Maximum Plunge Depth

The Tool Definition dialog has been enhanced to support some settings required for the Material Entry options in the Z Contour Roughing and Pocketing cycles. The new parameters are a **Centre Cutting Tool** checkbox and a **Maximum Plunge Depth** value.

These values will populate through to the machining cycles to control the tool plunge/entry criteria.

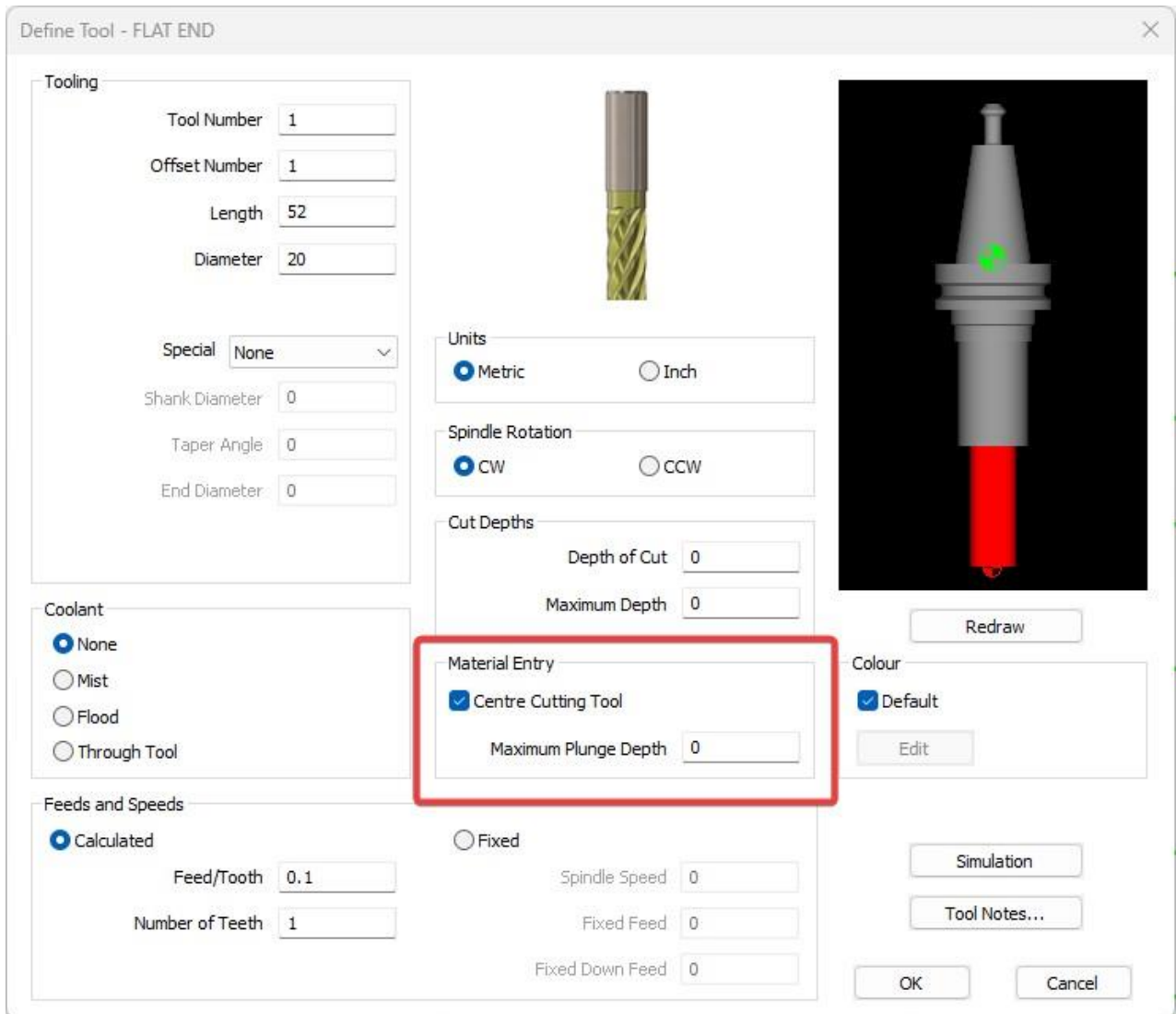

The screenshot shows the 'Define Tool - FLAT END' dialog box with the following settings:

- Tooling:** Tool Number: 1, Offset Number: 1, Length: 52, Diameter: 20, Special: None, Shank Diameter: 0, Taper Angle: 0, End Diameter: 0.
- Coolant:** None, Mist, Flood, Through Tool.
- Feeds and Speeds:** Calculated, Fixed. Feed/Tooth: 0.1, Number of Teeth: 1, Spindle Speed: 0, Fixed Feed: 0, Fixed Down Feed: 0.
- Units:** Metric, Inch.
- Spindle Rotation:** CW, CCW.
- Cut Depths:** Depth of Cut: 0, Maximum Depth: 0.
- Material Entry (highlighted):** Centre Cutting Tool, Maximum Plunge Depth: 0.
- Colour:** Default, Edit button.

Buttons: Redraw, Simulation, Tool Notes..., OK, Cancel.

Pocketing and Z Contour Roughing

Pocketing and Z Contour Roughing - Improved Ramp Entry Approach Type

When creating a new Pocketing or Z Contour Roughing cycle, the **Centre Cutting** and **Maximum Plunge Depth** parameters will be populated using the values stored with the tool:

- If **Centre Cutting Tool** is checked and the **Maximum Plunge Depth** is zero, ALPHACAM will assume that the tool can plunge to the required cutting depth and will not modify the ramp angle.
- If **Centre Cutting Tool** is unchecked and the **Maximum Plunge Depth** is zero, the tool cannot plunge into the material at all. It must approach from outside, if possible, or use a pre-drilled hole for the starting point.
- If a non-zero value is specified for the **Maximum Plunge Depth** that is less than the thickness of cut, ALPHACAM will calculate a maximum ramp angle that ensures that the maximum plunge depth of the tool is not exceeded. If this computed ramp angle is lower than the operation parameter, the computed value will be used instead.
- To achieve a Vertical Plunge (90 degree), you will need to use a Centre Cutting tool with a **Maximum Plunge Depth** greater than the cutting depth.

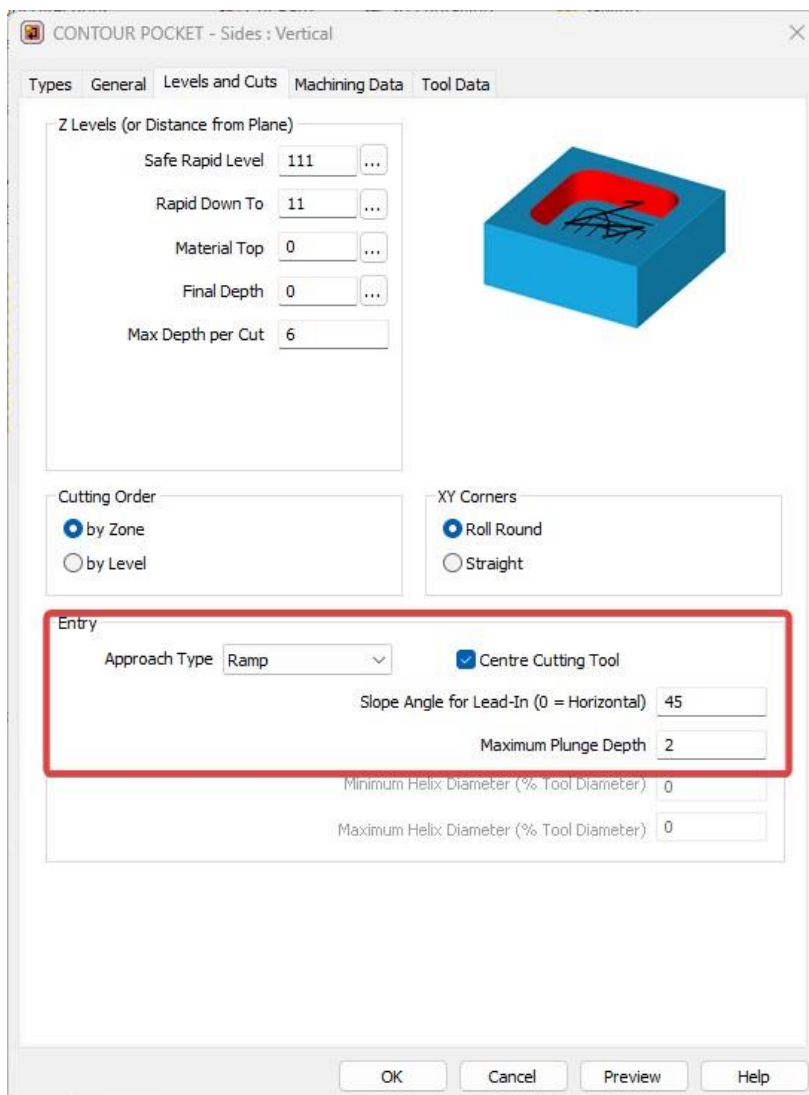

Pocketing

Pocketing - G41/G42 compensation Support for Finish Passes

Pocketing has been greatly improved to add advanced control over the Finish Pass. Users can now opt between the historic added Finish Pass Full Operation (**Add Cut Path Operation**) and new **Add Simple Finish Pass** and **No Finish Pass**:

- **Linear** Pocket can optionally have simple pass with comp and user-defined leads.
- **Contour** Pocket can optionally have simple pass with comp and user-defined leads.
- **Spiral** Pocket can optionally have simple pass with comp and user-defined leads.
- **Waveform** Pocket simple (silent) pass can now have comp and user-defined leads or Tool Centre.
- **Waveform** Pocket can now have no simple (silent) pass.

i

This control is not available for Profiled Sides Pocketing.

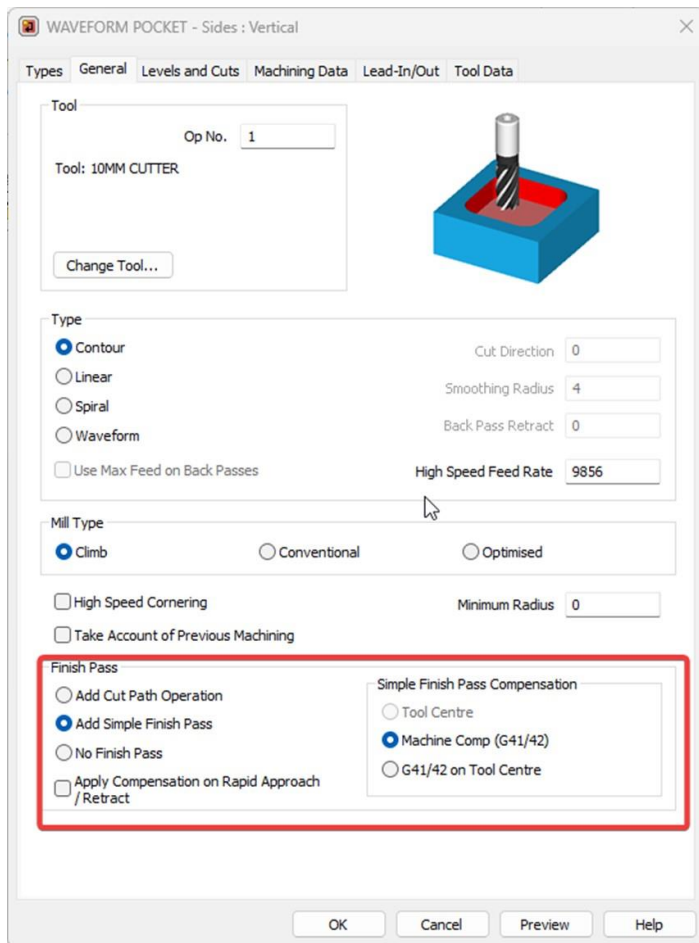

Tool Library

Tool Library - Addition of Centre Cutting and Max Plunge Depth fields

The Tool Library has been enhanced with the addition of **Centre Cutting** and **Max Plunge Depth** fields. The visibility of each can be toggled by right-clicking on the header-bar. By default, all Flat, Bull and Ball tools will be set to **Centre Cutting** and have a **Max Plunge Depth** of 0. The tool can be edited to change these parameters.



Name	Number	Type	Offset	5 Axis	Diameter	Radius / Cone Angle (Drill)	Maximum Plunge Depth	Centre Cutting	Length	Teeth	Fixed Feed	Fixed Speed	Note [TXT]
Flat - 10mm - Long	1	Flat	1		10.0	0.0	80.0	Yes	100.0	1	1000.0	18000	
Flat - 15 mm + holder	15	Flat	15		15.0	0.0	60.0	Yes	100.0	1	6000.0	18000	
Flat - 10mm - Copy	10	Flat	10		10.0	0.0	50.0	No	100.0	2	5000.0	18000	
Flat - 12 mm + holder	12	Flat	12		12.0	0.0	15.0	Yes	25.0	6	8000.0	10000	
12mm 5Axis Tool	999	Ball	998	****	12.0	6.0	0.0	Yes	50.0	1	6000.0	18000	

A further change has been implemented where any changes that are made to column ordering and widths within the Tool Library in ALPHACAM 2025.2 will be remembered in 2025.2 onwards and will not affect the Tool Library in older versions of ALPHACAM. Once there is a saved setup from ALPHACAM 2025.2, changes made to the Tool Library in older ALPHACAM versions will no longer affect ALPHACAM 2025.2.

Solid Simulation

Solid Simulation - The addition of stock comparison

The ability to compare the Simulation result to the original solid model has been implemented into Solid Simulation. The new **Part Compare** command is in the **Commands** section of the **Simulation** tab.

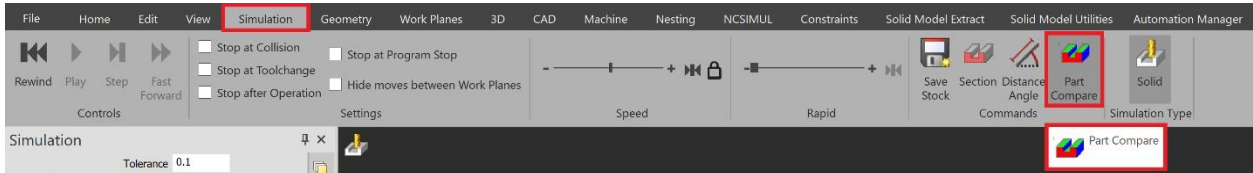

For the Part Comparison to work, it requires a solid model or STL which has the **Set as Simulator**

Part option set in the layers tree. This option can be found in the right click context menu of the Solid Model or STL. If the **Set as Simulator Part** option has not been set in a target part, the command will be disabled.



Clicking the plus or minus buttons will increase or decrease the number of ranges and colours used for the part comparison.

Solid Simulation - Improved Part visibility

When **Set as Simulator Part** is used to send a model to SIMNC, the part is no longer shown during simulation. The **Section** command now has a new **Show Simulator Part** checkbox that is OFF, by default. The target solid model will only be visible when the **Show Simulator Part** checkbox is selected and the **Section** command dialog is open; once the dialog is closed, the target solid model will be hidden.

Show Simulator Part – Off:

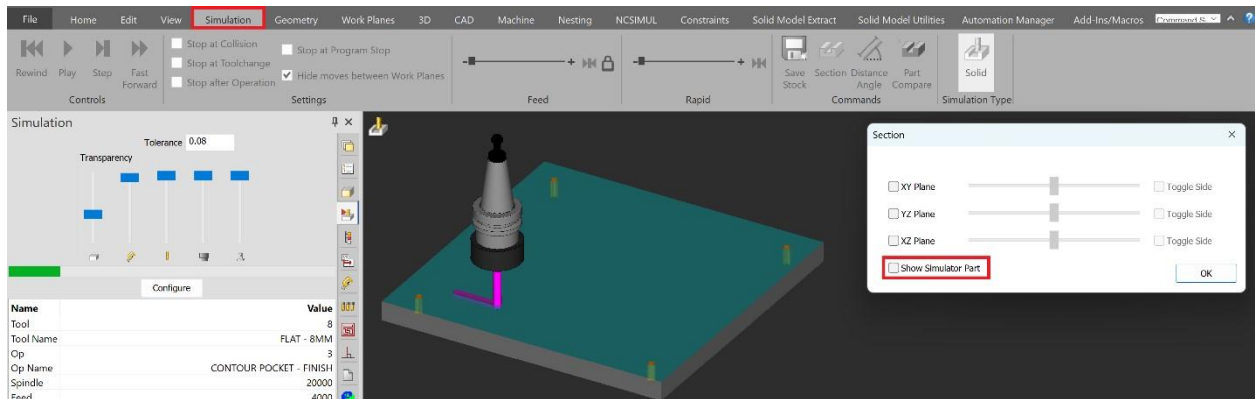

Show Simulator Part – On:

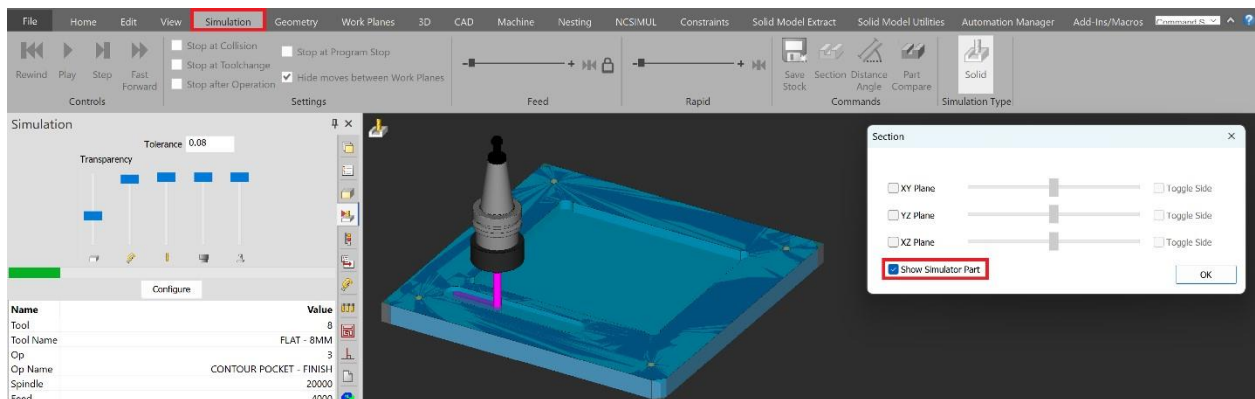

Simulation

Simulation - Sectioning - Include Part

When creating a sectioned view in simulation, if the Part has been included, then the Part will be sectioned and shown in a darker shade of the Material colour.

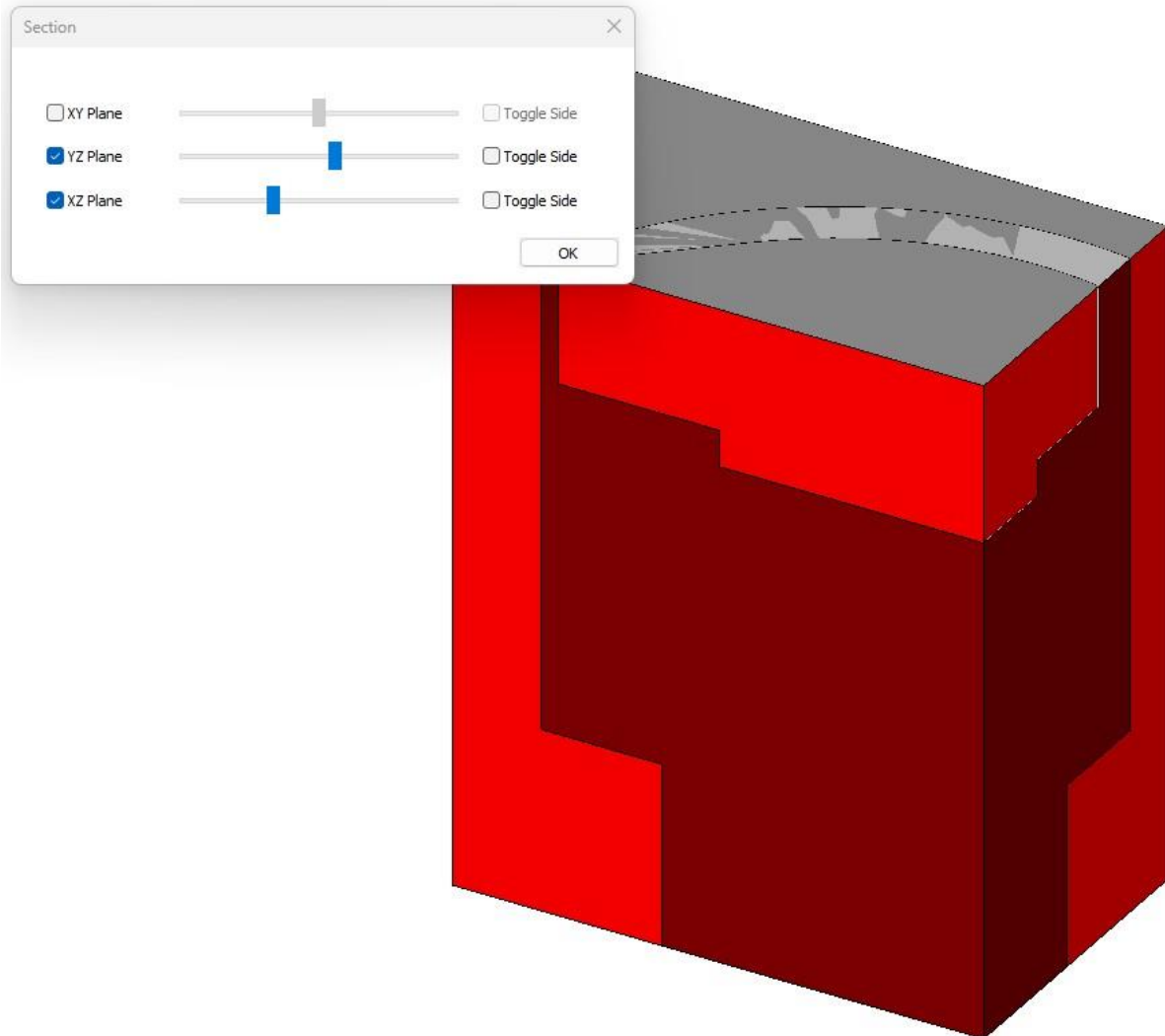

Radial Menu

Radial Menu - Improved defaults

The default commands contained within the Radial menu have been updated.

Newly added commands:

- Tool Directions.
- Tool Data Sync.
- Dimensions.
- Text.
- Simulation View (Solid Simulation).
- Play Simulation.

	<p>Some defaults are module specific i.e. Simulation and Tool Data Sync.</p>
---	--

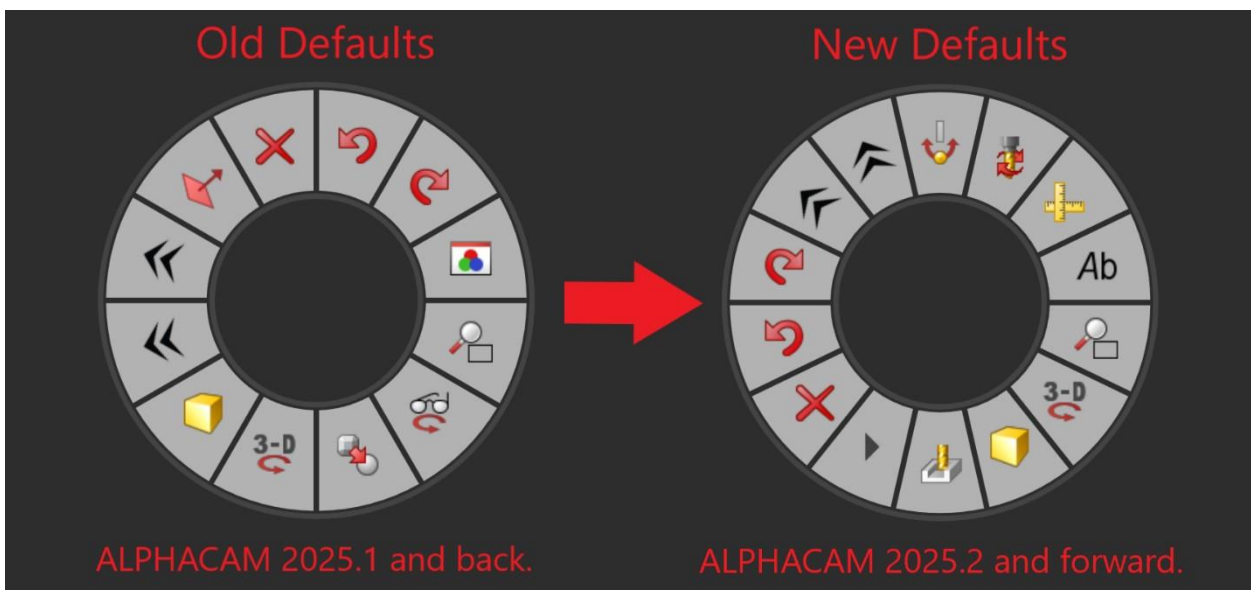

Feature Extraction

Feature Extraction - Minimum Bounding Box alignment

A new **Use Minimal Bounding** Box alignment checkbox has been added to Feature Configuration. The new option is switched on by default. When this option is used, a minimal bounding box will be constructed, and the longest edge of that box used instead of evaluating the solid edges, to decide which edge should be aligned with the X or Y axis.

This is particularly useful when trying to align nonlinear parts.

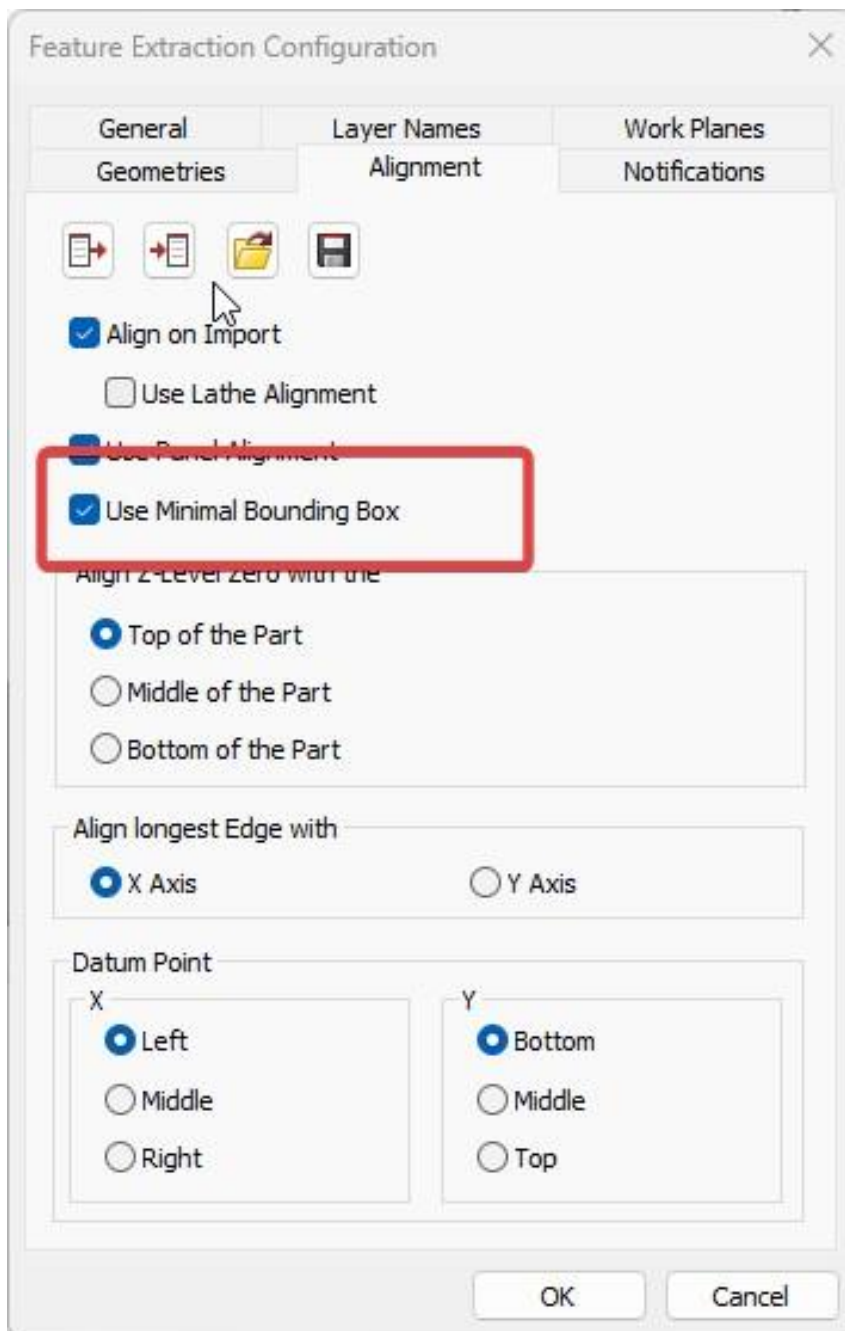

Parametric Sketcher

Parametric Sketcher - The addition of a local Undo to work with Run

Three new buttons have been added to the **Run** section of the Parametric Sketch dialog ribbon bar: **Undo**, **Redo** and **Clear Drawing**.



After running a sketch:

- **Undo** can be used to remove it from the drawing.
- **Redo** can be used to restore it to the drawing.
- If several sketches are added, pressing **Undo** several times will remove them one at a time until they are all gone; the **Undo** button will be disabled at this point. The **Redo** button has the same behaviour; pressing **Redo** several times will bring the sketches back one at a time.

The **Clear Drawing** button is a toggle button. When highlighted, running a sketch will empty the drawing first. When it is not highlighted, running a sketch will add to the drawing.

Run Parametric Sketch

Within the **Run Parametric Sketch** command dialog, a **Clear Drawing** checkbox has been added under the preview window:

- If **Clear Drawing** is checked, when **OK** is pressed, the drawing will be cleared before the sketch is inserted.
- If **Clear Drawing** is unchecked, a new sketch will be added to the drawing.

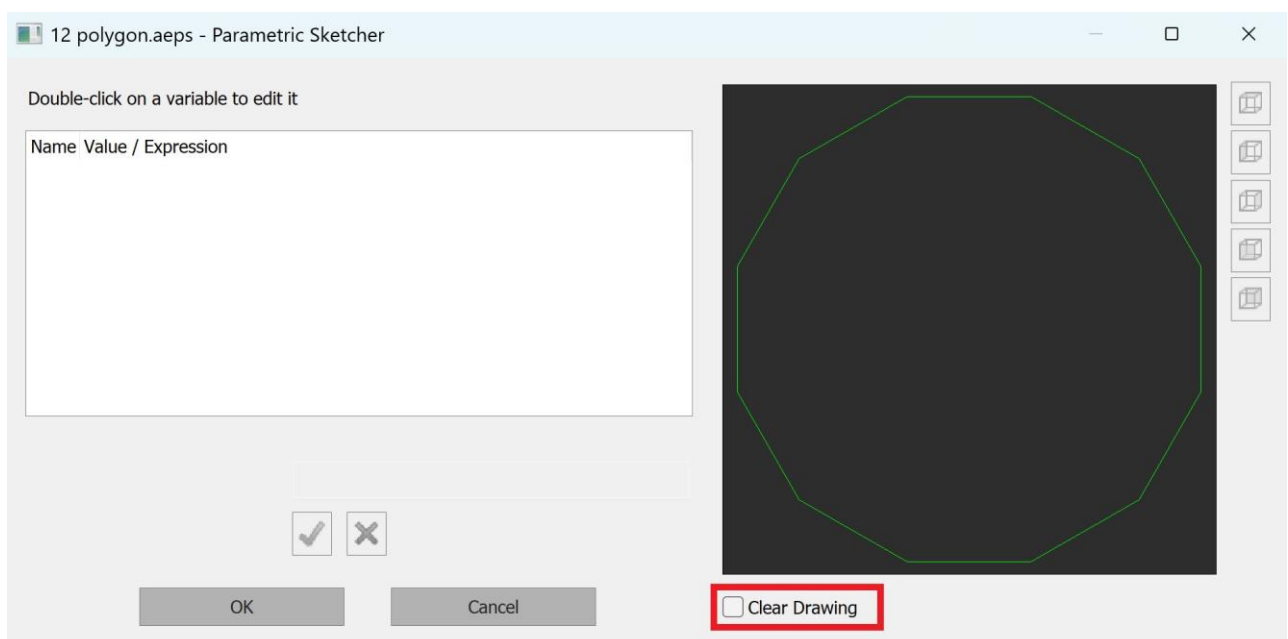

Parametric Sketcher – Increased number of Variables available

Previously, you could only create a maximum of 16 variables but, in this version, you can create as many variables as required:

- A single variable expression or command parameter expression can reference, at most, 20 variables and constants in total. Warning messages will be displayed if you exceed this value.

If you ever encounter this variable limit in an expression, it is possible that creating another variable to store a partial calculation result would allow you to work around this limitation.

- Existing sketches behave as in previous versions.

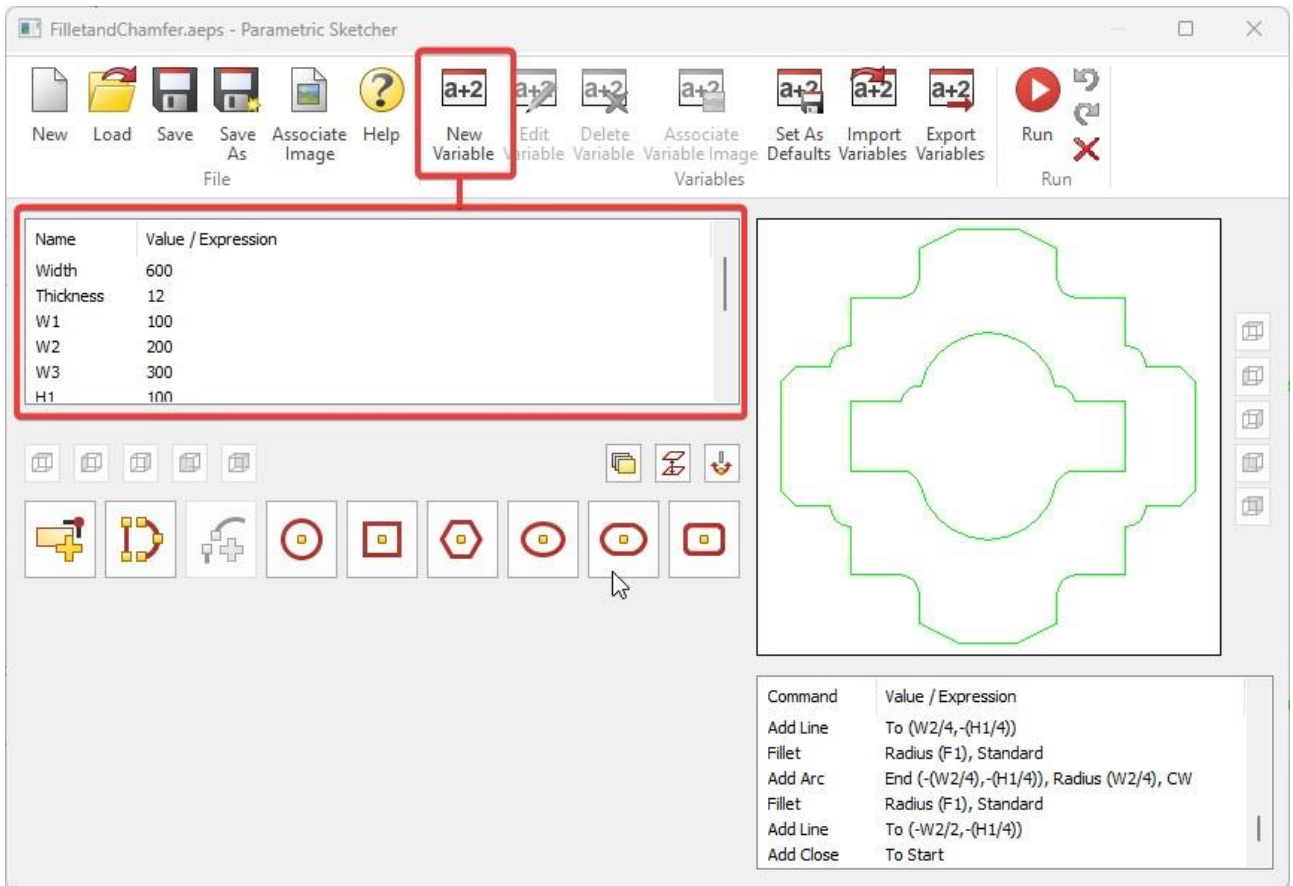

Parametric Sketcher - Fillet creation – T-Bone Fillet support added

The Parametric Sketcher has been updated to include the new **T-Bone** Fillet type. The Fillet is defined by radius and direction parameters. The direction can match the line going into the corner or the line coming out of the corner.

	<p>T-Bone Fillets can only be applied between two Line Elements.</p>
---	--

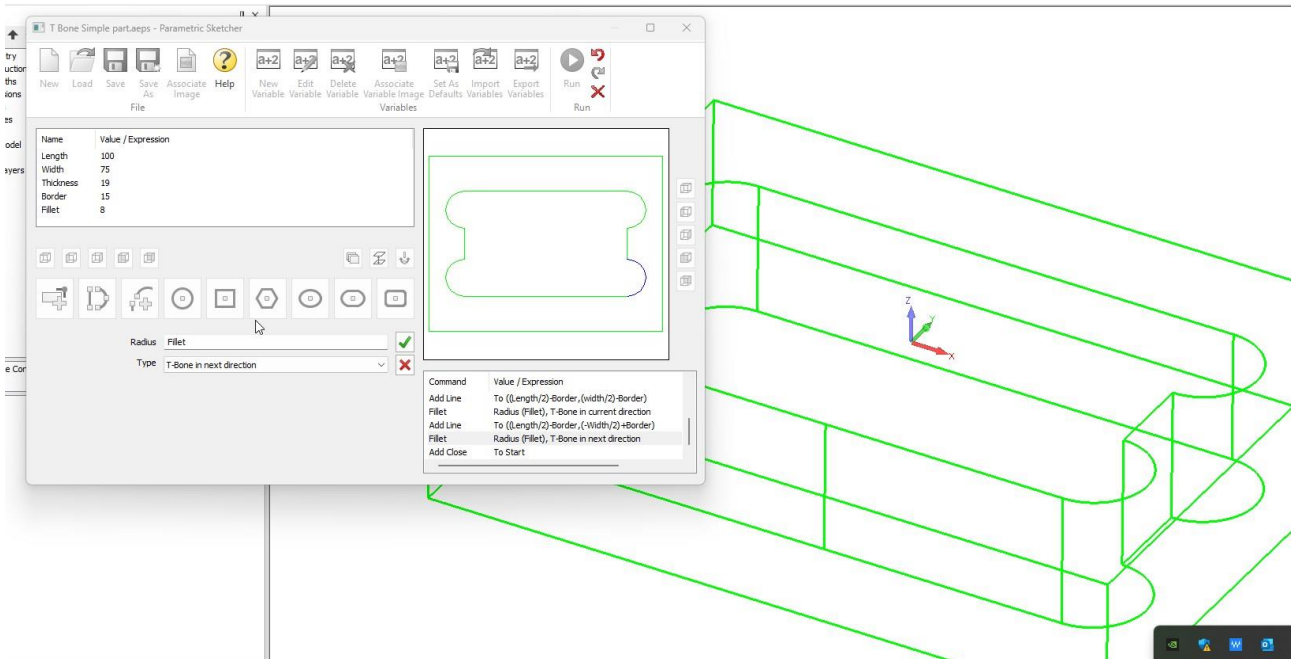

Parametric Sketcher- Ability to add comments to the command list

A new **Comment** command type has been added for this release. These comments include descriptive text for user information and can be added, inserted, edited, and deleted from the command listing.

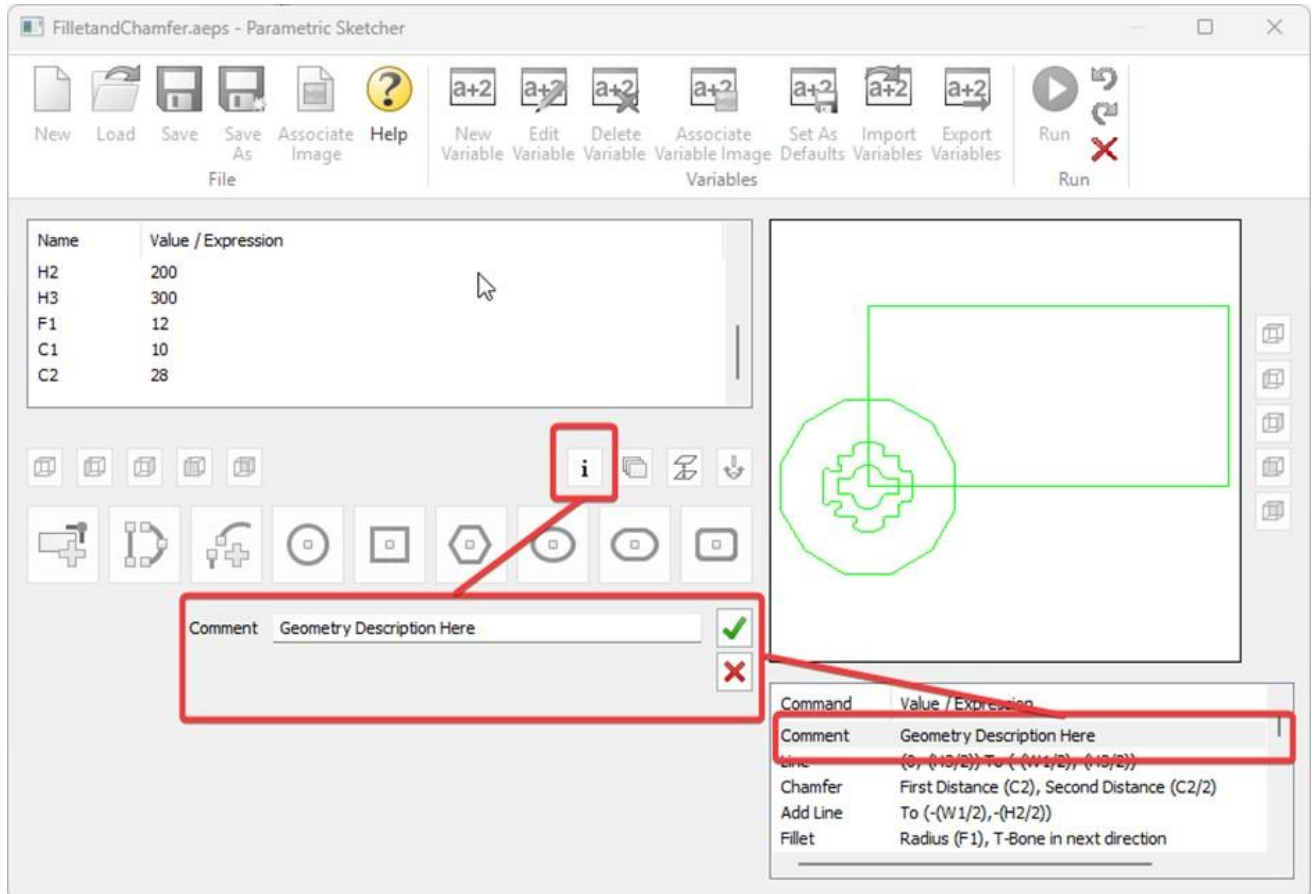

Geometry

Geometry - Open Elements - Support element colour for transparent Rendering

The Graphical Display of Open Elements with Z Levels has been improved to support the colour of the element.

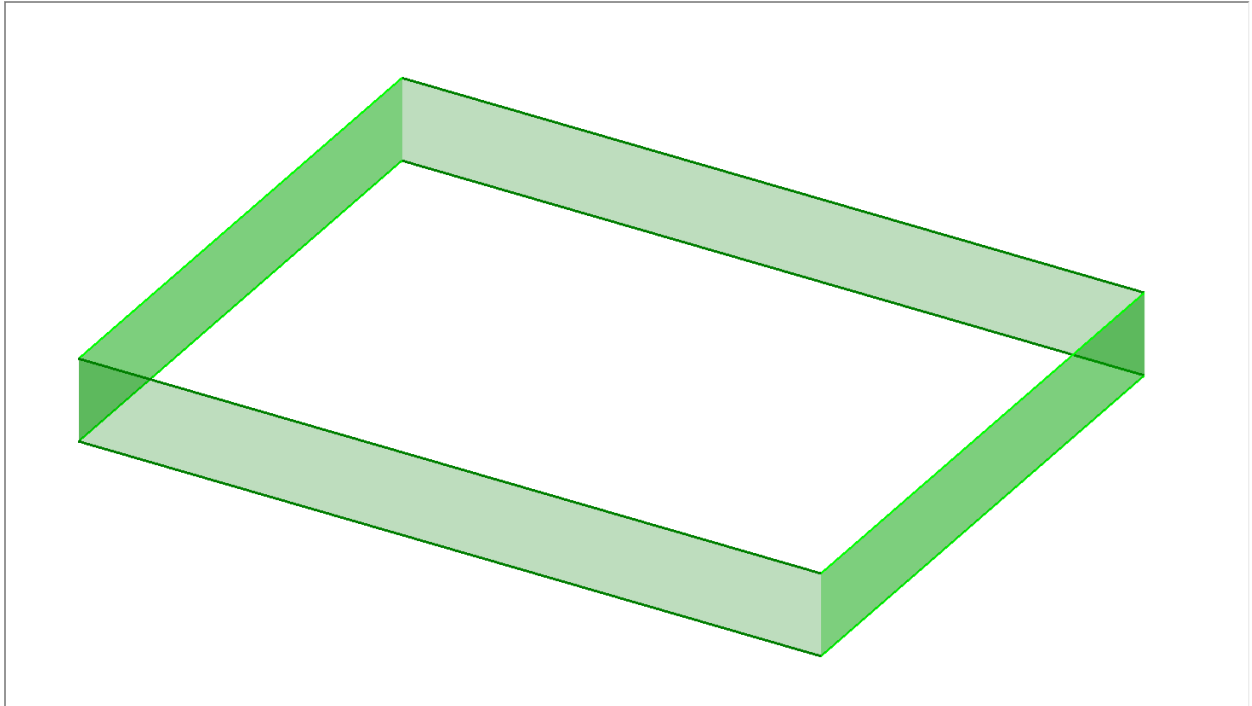

Dimension

Dimension - Alternate Units - Unit Multiplier - Increase Decimal Places

It is now possible to set the **Unit Multiplier** to 10 decimal places in the **Alternate Units** tab of the **Dimensions** dialog. The value entered will be stored within the **Alternate Units** tab and will be used whenever dimensions are applied with the **Show Alternate Units** option active.

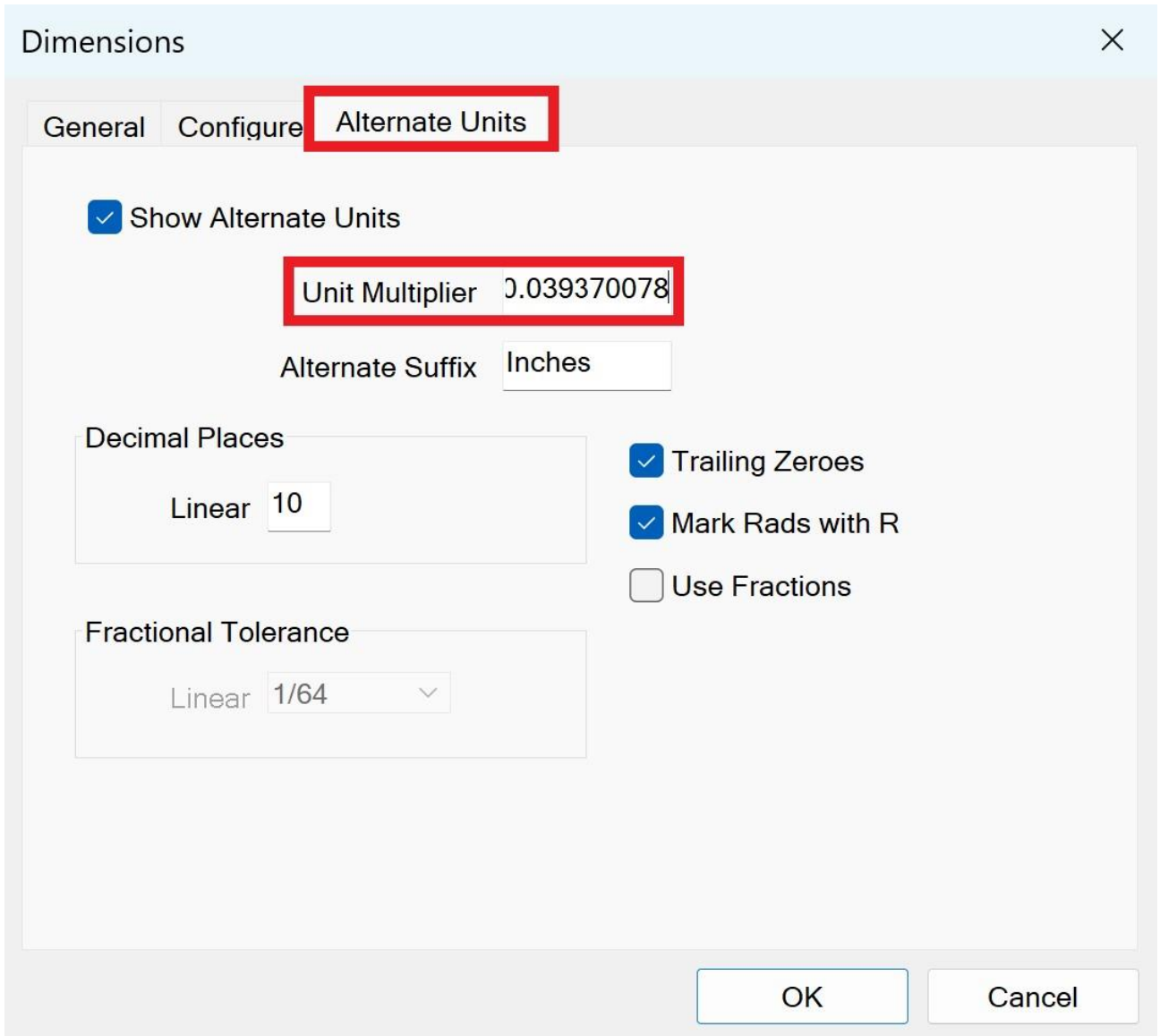

Dimensions ×

General Configure **Alternate Units**

Show Alternate Units

Unit Multiplier 0.039370078

Alternate Suffix Inches

Decimal Places

Linear 10

Fractional Tolerance

Linear 1/64

Trailing Zeroes

Mark Rads with R

Use Fractions

OK Cancel

Solid Models

Solid Models - Face Selector - New 'Cylindrical Faces of same Diameter' option

For this release, we have added a new **Cylinders with same diameter** button to the **Face Selector**.

If the last picked face is a cylinder, the new button will be enabled. Pressing it will toggle selecting all of the other cylinders with the same radius which exist on that same solid body.

For example, if you use the **Set Face Colour** command and then pick a cylinder, pressing **Cylinders with same diameter** will find all cylinders of the same radius regardless of direction and hollowness.

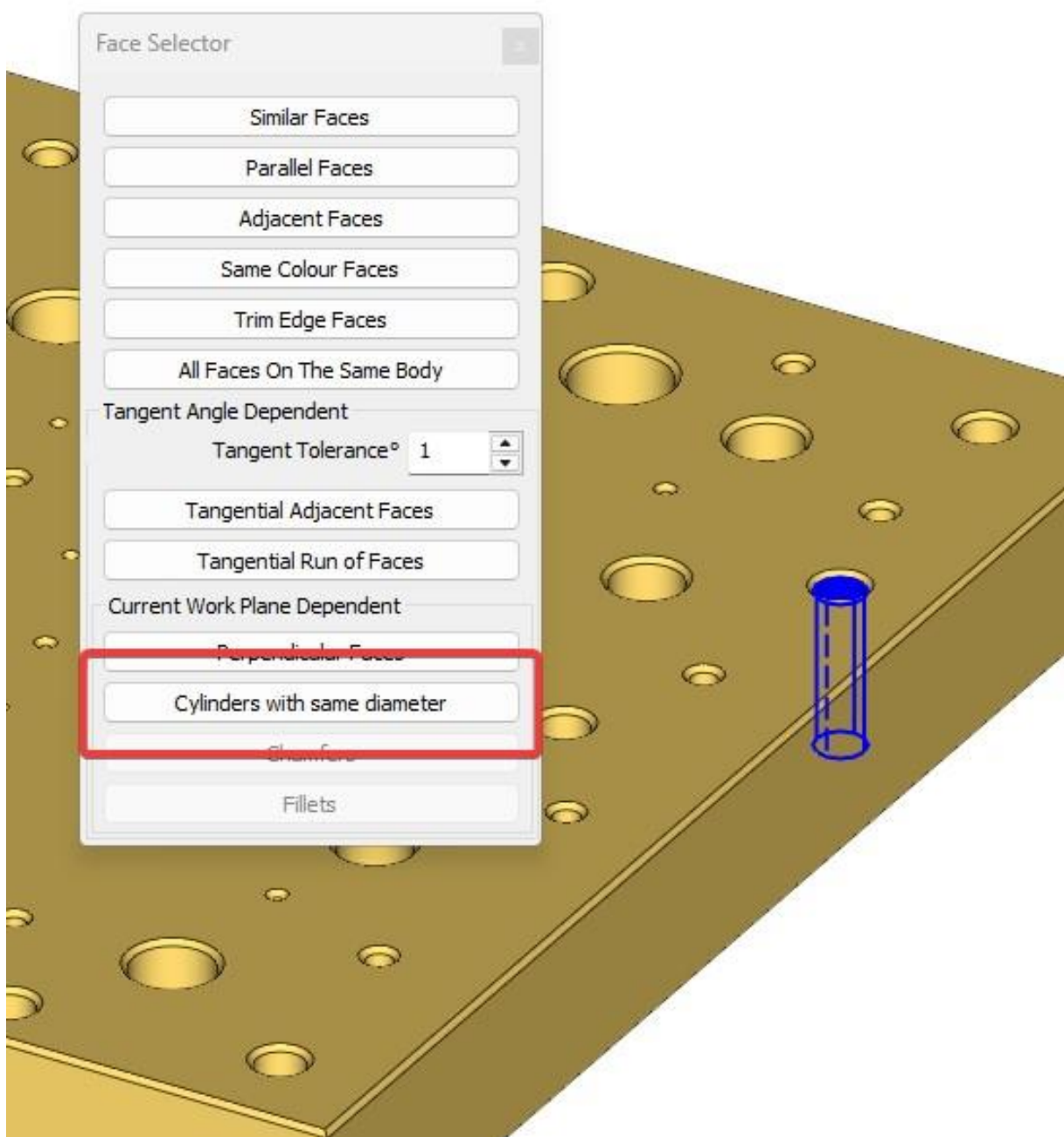

Automation Manager

Automation Manager - Layer Mapping – Multi-selection support of Tool Directions

It is now possible to multi-select Machining Styles within a **Layer Mapping Setup** and apply the same **Tool Direction Settings** and **Start Point Settings** to all selected items. When multiple Machining Styles are selected, the property grid is changed to only display **Tool Direction Settings** and **Start Point Settings**.

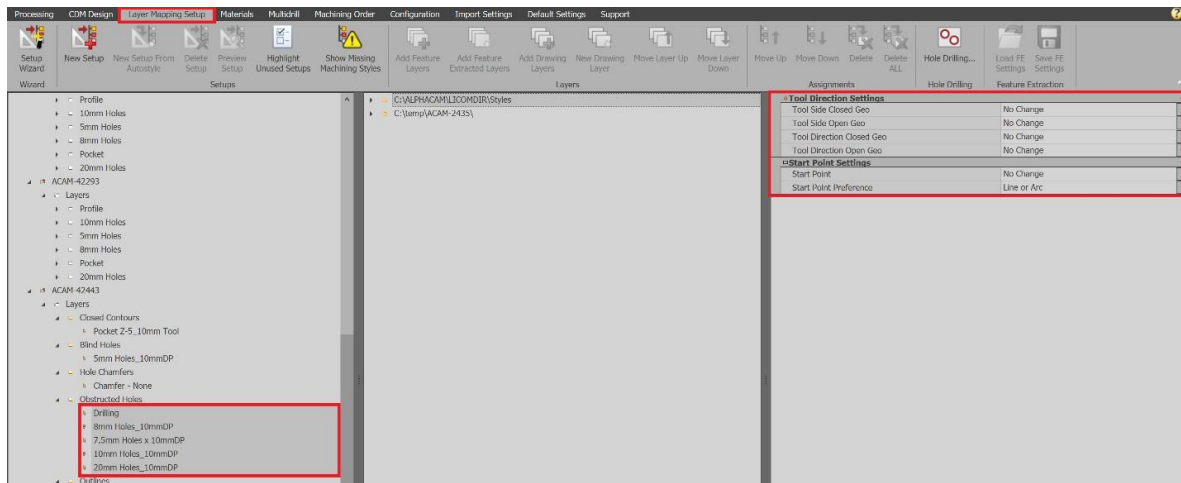

If multiple Machining Styles are selected which have different parameters defined, an additional **[Different Tool Side Closed Geos Selected]** drop-down option is added.

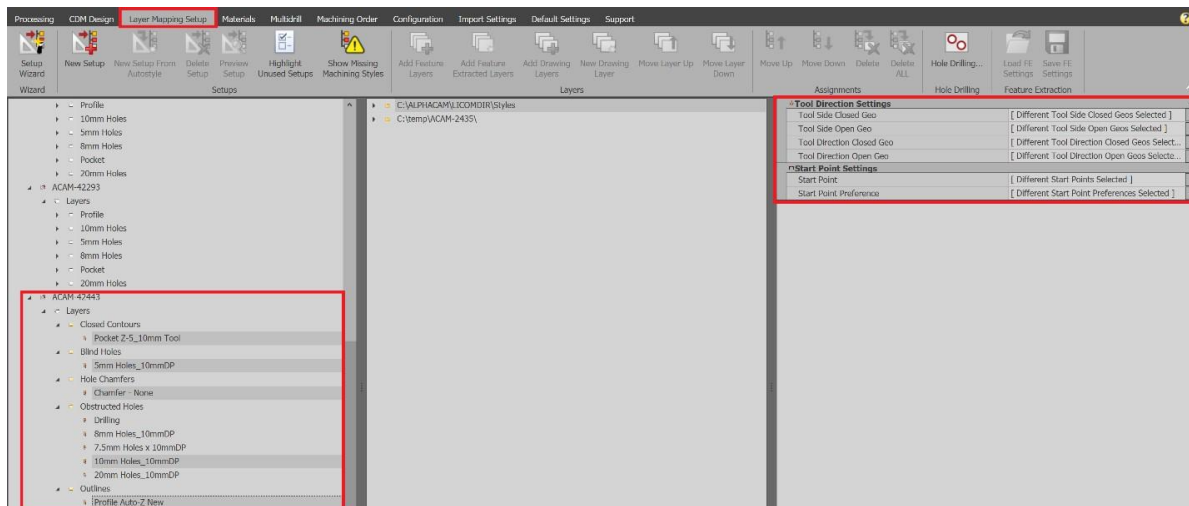

- When multiple Machining Styles are selected, the **Move Up** and **Move Down** ribbon buttons will be disabled.
- It is not possible to select Styles within different Layer Mapping Setups.
- Drag and drop for rearranging Styles will not work when multiple Styles are selected.
- It is not possible to use the **Shift** key and select all the Machining Styles which are present in different layers within a Layer Mapping Setup due to the Layers being in between. The only way to do this is using **Ctrl** + mouse click.

Automation Manager - Initial Rotation Angle Alignment

A new **Initial Alignment Angle** option has been added to the **Part Settings** within the **Processing** tab of **Job Files**. When checked, it allows the manual entry of a numeric value or allows the user to pick an entity to set an angle. The nest rotation method is hidden when this option is active:

- The selection process is different for a solid model because the user is asked to pick an edge for alignment rather than a 2D geometry. It is only possible to pick straight line entities to determine the angle.
- When processing a job, the file is rotated by the amount specified and locked to prevent any rotation being applied from nesting. The **Initial Alignment Angle** is applied after any auto-align settings defined in the layer mapping setup. This will allow panel alignment to be used where needed and will allow the part datum to be shifted to the user requirements.

Part Settings	
Item Number	1
Length (Along Y)	500
Width (Along X)	500
Default Material Thickness	0
Part Origin	No Change
Turn Part Over For Machining	<input type="checkbox"/>
Part Alignment Method	Initial Rotation Angle
Initial Alignment Angle	45
Drilling Configurations	Select Drilling Configurations

Automation Manager - Align by Minimum Bounding Box - Support in Layer Mapping

The **Use Minimum Bounding Box Alignment** option has been added to the **Solid Alignment Settings** within the **Layer Mapping Setup** tab. When active, the option will apply to all parts within a job that has the Layer Mapping Setup selected. The option to apply **Use Minimum Bounding Box Alignment** at Job File level is still available if the user requires a different alignment direction for individual Job Files.

Main Settings		
Setup Name	Solids New	
What To Extract	Both	▼
Geometry Query		...
Geometry Auto Query		...
Retain Solid After Processing	<input checked="" type="checkbox"/>	
Create Work Volume	<input type="checkbox"/>	
File Import Settings		
Create Geometry Z Levels from Parallel Planes	<input type="checkbox"/>	
Convert Spline to Lines/Arcs	<input type="checkbox"/>	
Project 3D to 2D	<input type="checkbox"/>	
Common Line Removal	<input type="checkbox"/>	
Solid Alignment Settings		
Auto Align Part	<input checked="" type="checkbox"/>	
Datum Point X	Left	▼
Datum Point Y	Bottom	▼
Datum Point Z	Bottom	▼
Use Panel Alignment	<input checked="" type="checkbox"/>	
Align Longest Edge With	Align Longest Edge With Y-Axis	▼
Align Vector With	X-Axis	▼
Use Minimum Bounding Box Alignment	<input checked="" type="checkbox"/>	
Align Longest Edge With	Align Longest Edge With Y-Axis	▼

Automation Manager - Layer Mapping – Multi-select Delete Layers and Styles

To further improve workflow within Automation Manager, the ability to multi-select and delete Layers has been implemented. The **Shift** key cannot be used to multi-select Layers as each of the different Layer nodes is separated by Styles. It is only possible to multi-select multiple Layers by using the **Ctrl** key and clicking on each Layer. It is not possible to multi-select Layers across multiple setups:

- When Layers are multi selected, the property grid on the right side will not show any information except the regular message that there are no editable items.
- When multiple Layers are selected, a **Delete Layer(s)** right click context menu option is available. The same option is active in the ribbon bar, but all other options related to Layers and assignments will be disabled.
- Deleting multiple layers together will also delete the assignments, if any, within them.

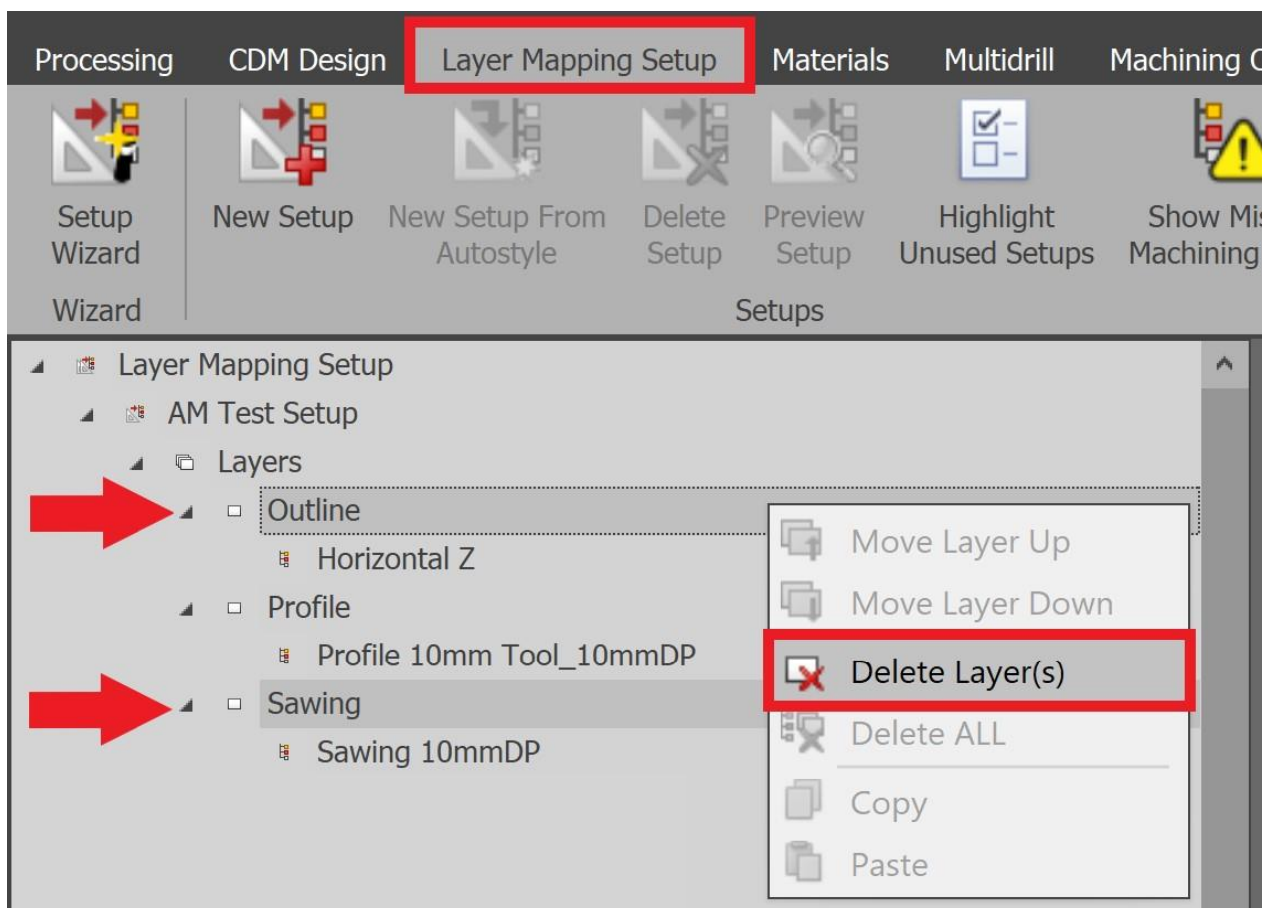
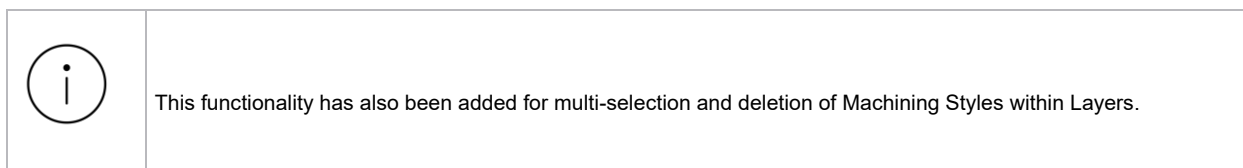

Automation Manager - Consolidate Alignment Methods

The **Use Vector Alignment**, **Use Minimum Bounding Box Alignment** and **Use Initial Rotation Angle Alignment** checkbox fields have been removed and replaced with a consolidated **Part Alignment Method** drop-down menu which contains the alignment methods for solid parts. Selecting the different methods here will show the relevant alignment options as child rows.

Job File	Length (Along Y)	Width (Along X)	Quantity Required	Cu...
150x200.VDF	150	200	1	ABC
200x200 W_Pocket.VDF	200	200	1	ABC
250x250 W_Pocket.VDF	250	250	1	ABC
250x500 W_Pocket.VDF	250	500	1	ABC

Main Settings	
Filename	C:\Users\matthew.diggens\OneDrive...
Part Name	150x200.VDF
Layer Mapping Setup	
Machining Order	From Job
Materials	
Material	From Job
Part Settings	
Item Number	1
Length (Along Y)	150
Width (Along X)	200
Default Material Thickness	10
Part Origin	No Change
Turn Part Over For Machining	<input type="checkbox"/>
Part Alignment Method	None
Drilling Configurations	None
Nested Part Settings	
Nest Part	Vector Alignment
	Minimum Bounding Box
Quantity Required	Initial Rotation Angle

Automation Manager - Option to Sort Layer Mappings by alphabetical order

For this release, the ability to sort Layer Mapping Setups alphabetically has been added. A new **Order Setups Alphabetically** button has been added to the **Layer Mapping Setup** tab. When active, all setups will be ordered alphanumerically but no ordering will be applied to the child nodes (Layers or Machining Styles).

Processing	CDM Design	Layer Mapping Setup	Materials	Multidrill	Machining Order	Configuration	Import Settings
Setup Wizard	New Setup	New Setup From Autostyle	Delete Setup	Preview Setup	Highlight Unused Setups	Show Missing Machining Styles	Add Feature Layers
							Order Setups Alphabetically

Layer Mapping Setup
Order Setups Alphabetically

Automation Manager - Machining Order – Display items in use by Jobs

If a user deletes a **Machining Order** which is in use by Automation Manager, CDM jobs or is currently set as the default setting in **Job Defaults** within the **Default Settings** tab, Automation Manager will display a message confirming whether the user wants to delete the **Machining Order**. If the user chooses **Yes** and the **Machining Order** is in use, a dialog will open displaying which jobs are using this ordering and whether it is set as a default setting.

Pressing **OK** on the feedback dialog will proceed with deleting the **Machining Order**; otherwise, the user can press **Cancel** and it will not be deleted.

	<p>Any jobs that were using the now deleted Machining Order will display the default message of No Machining Order Selected within the Machining Order section in the Processing tab; this is the same for default settings.</p>
---	--

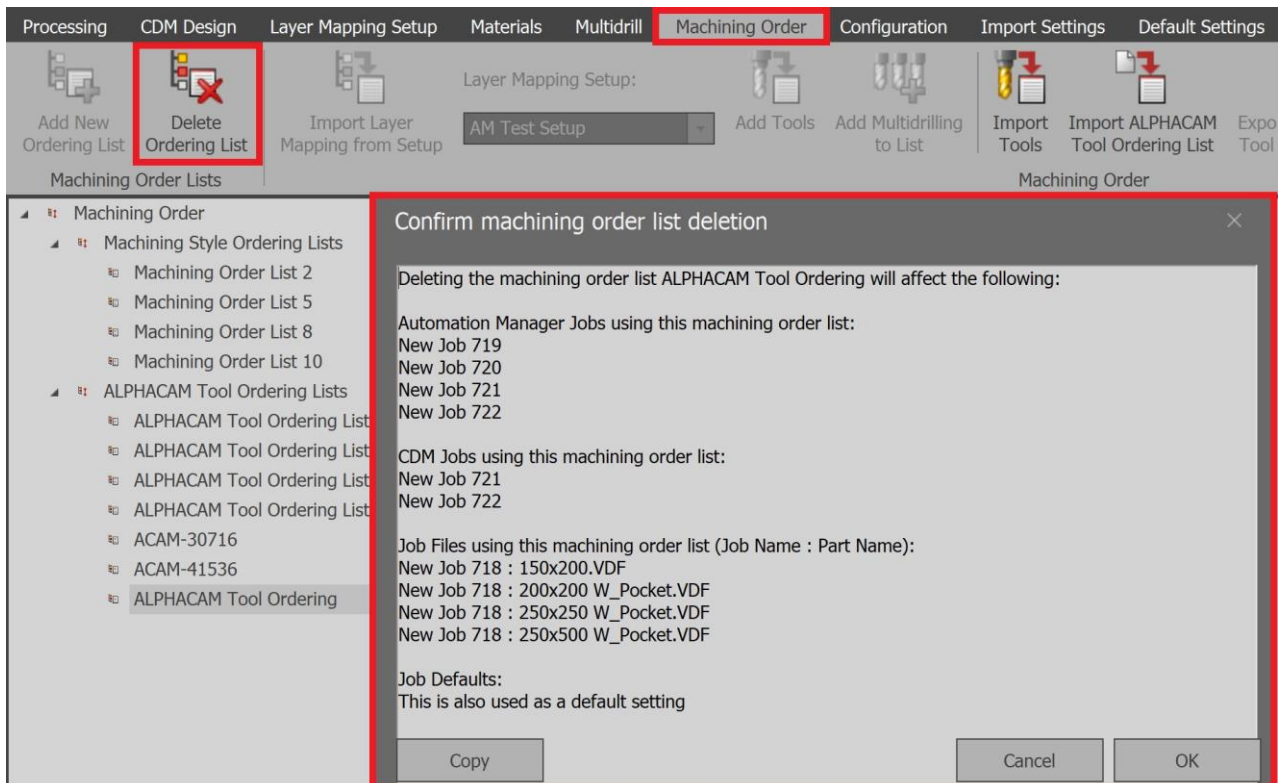

The screenshot shows the 'Machining Order' tab in the software interface. A dialog box is open, titled 'Confirm machining order list deletion'. The dialog contains the following text:

Deleting the machining order list ALPHACAM Tool Ordering will affect the following:

Automation Manager Jobs using this machining order list:
 New Job 719
 New Job 720
 New Job 721
 New Job 722

CDM Jobs using this machining order list:
 New Job 721
 New Job 722

Job Files using this machining order list (Job Name : Part Name):
 New Job 718 : 150x200.VDF
 New Job 718 : 200x200 W_Pocket.VDF
 New Job 718 : 250x250 W_Pocket.VDF
 New Job 718 : 250x500 W_Pocket.VDF

Job Defaults:
 This is also used as a default setting

Buttons: Copy, Cancel, OK

Automation Manager - Layer Mapping Setups - Expand/Collapse All Layers

For this release, **Expand Layers** and **Collapse Layers** options have been added to the right click context menu of each **Layer Mapping Setup**. The new **Expand Layers** option will expand all the child nodes of the selected setup and **Collapse Layers** will collapse all child nodes.

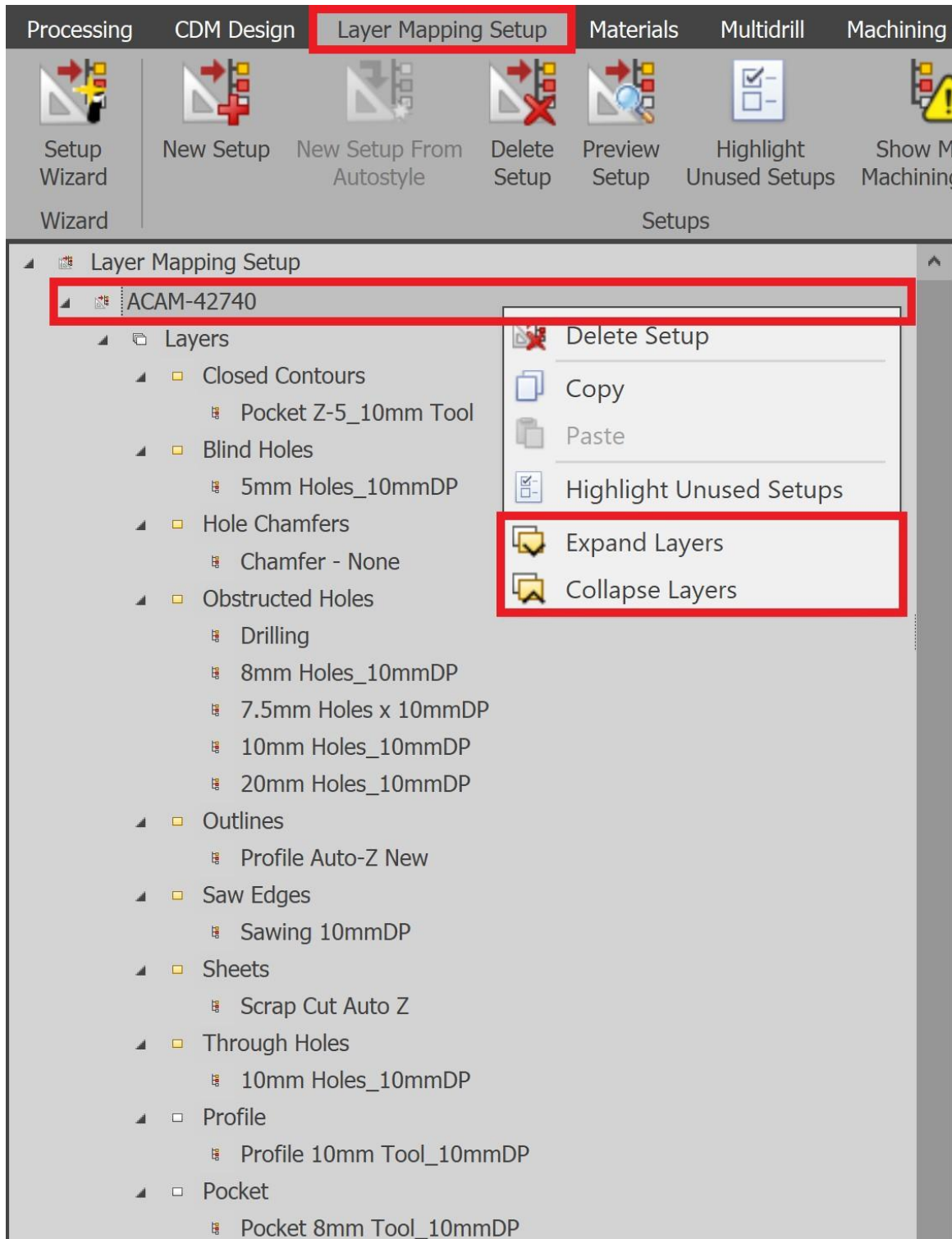

Automation Manager - Nest Part Rotation to be active with Initial Part Angle

When Custom Alignments (Vector Alignment, Minimum Bounding Box Alignment or Initial Alignment Angle) are in use, **Any Angle** rotation is not available from Nest Part Rotation Method within the Nested Part Settings for part files.

If a part is defined with no custom rotations and Nest Part Rotation is set to **Any Angle** (either from the part nesting options or from Configuration – Job File Defaults), then selecting a Custom Part Alignment Method will display an information message advising that the Nest Part Rotation Method has been changed to **Fixed**.

ALPHACAM



Nest Part Rotation Method has been changed to Fixed as a result of a change in Part Alignment Method

OK

Automation Manager - A ribbon button to highlight unused Machining Orders

To assist users in distinguishing unused Machining Orders in Automation Manager, a new **Highlight unused Ordering Lists** option has been added to the **Machining Order** tab and the right click context menu of the main Machining Order node and of each Ordering.

Once clicked, it will highlight all of the unused Machining Orders that are currently not in use by any of the jobs/job files in Automation Manager or not set as the Default Machining Order in Job defaults within the Default settings tab.

Any unused Machining Orders will be highlighted in yellow and hovering over the highlighted node will display a tooltip stating **This Ordering List is not in use**. Switching to another tab and back to **Machining Order** will remove the highlights.

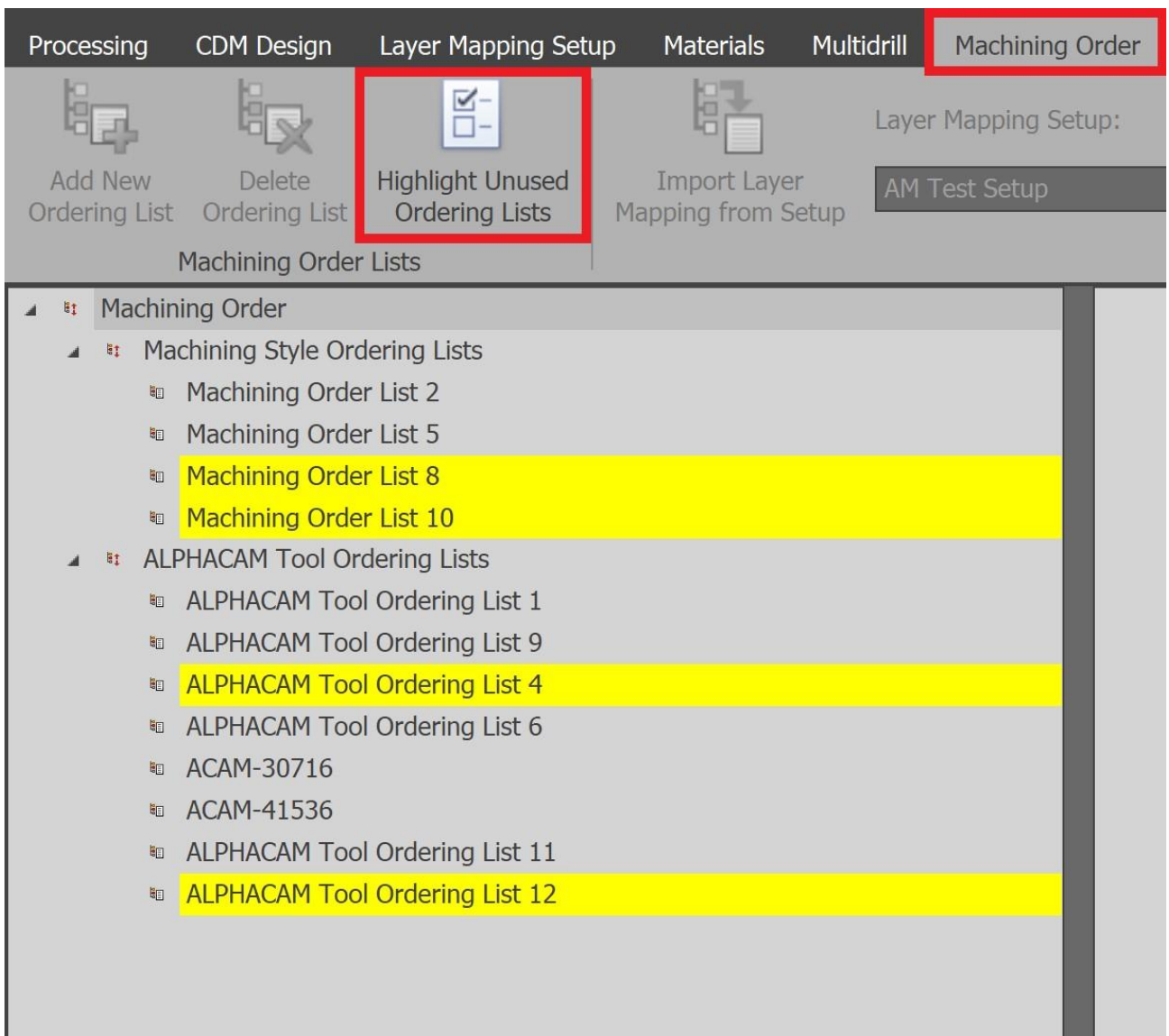

The screenshot displays the Automation Manager interface. The ribbon is set to the **Machining Order** tab, which is highlighted with a red box. The ribbon contains several buttons: **Add New Ordering List**, **Delete Ordering List**, **Highlight Unused Ordering Lists** (highlighted with a red box), and **Import Layer Mapping from Setup**. Below the ribbon, the **Machining Order Lists** section is visible, showing a tree view of the **Machining Order** node. The tree view includes **Machining Style Ordering Lists** and **ALPHACAM Tool Ordering Lists**. Several items are highlighted in yellow, indicating they are unused: **Machining Order List 8**, **ALPHACAM Tool Ordering List 4**, and **ALPHACAM Tool Ordering List 12**. The **AM Test Setup** button is also visible in the ribbon.

Automation Manager - Layer Mapping Setups - Support manual drag and drop ordering

To further improve workflow within the **Layer Mapping Setup** tab of Automation Manager, the ability to manually drag and drop to sort Layer Mapping Setups has been implemented.

	If alphabetical sorting is active, drag and drop sorting will be disabled.
---	--

Automation Manager - Option to Apply Machining to Each Layer Entity One by One

A new **Apply To Each Geometry Individually** option has been added to Layer Mapping Setups. When active, machining is applied to each geometry within the layer, one by one, resulting in overlapping geometries being fully machined.

Main Settings	
Layer Name	POCKET
Machining Style Name	LICOMDIR\Styles\ACAM-43234\Contour... ...
Z level Settings	
Use Geometry Z Levels If Present	<input checked="" type="checkbox"/>
Auto Z Level Top	0
Auto Z Level Bottom	0
Tool Direction Settings	
Tool Side Closed Geo	Auto Pocket ▼
Tool Side Open Geo	No Change ▼
Tool Direction Closed Geo	No Change ▼
Tool Direction Open Geo	No Change ▼
Start Point Settings	
Start Point	No Change ▼
Start Point Preference	Line or Arc ▼
Machining Specific Settings	
Apply To Each Geometry Individually	<input checked="" type="checkbox"/>

Apply To Each Geometry Individually

If checked, the machining style will be applied to each geometry within the layer individually, preventing unwanted results from overlapping geometries

If the new **Apply To Each Geometry Individually** option is deactivated, the behaviour will remain unchanged, and machining will only be applied to the intersecting space.

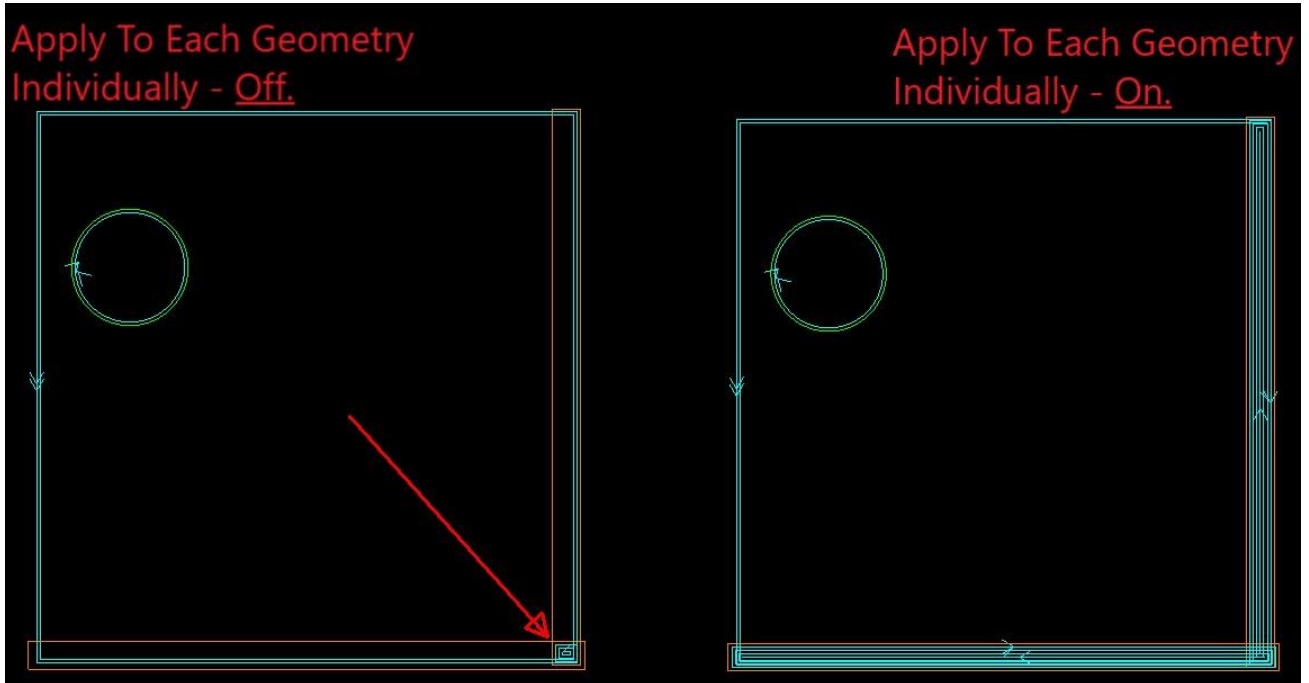

The new option has also been added to AutoStyles:

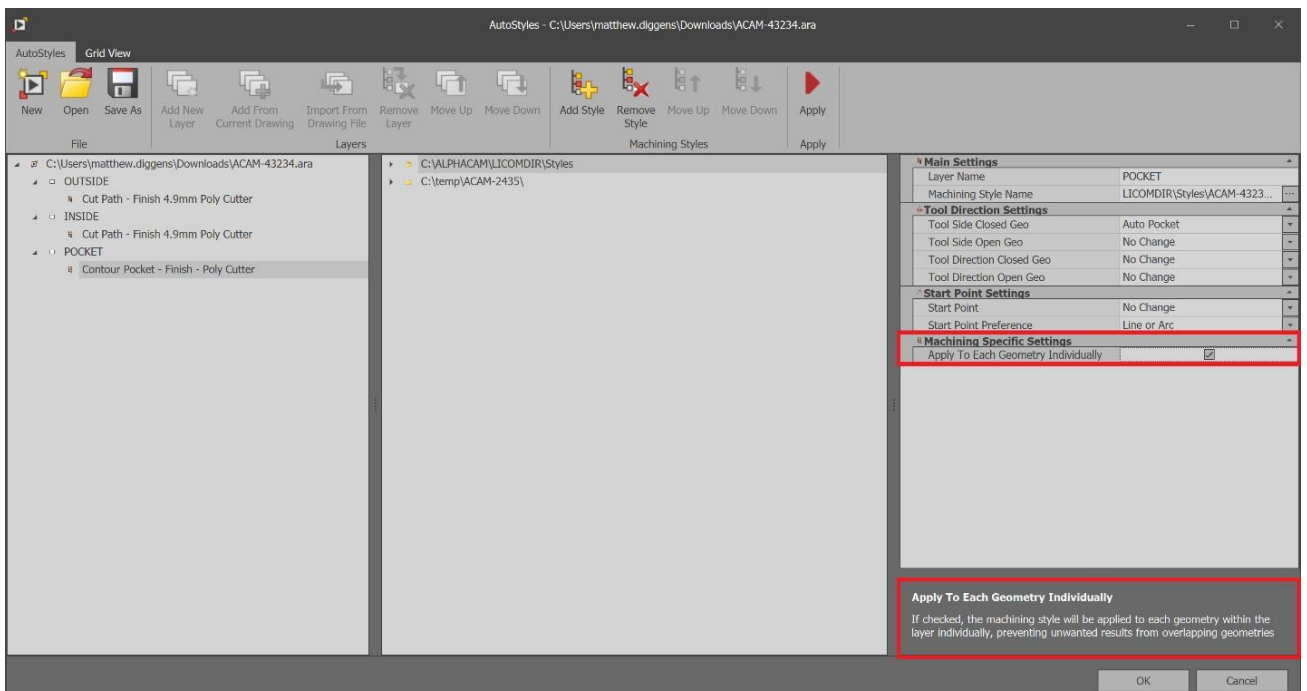

Automation Manager - New Job Commands to always be Active

To further improve workflow within Automation Manager, it is now possible to create Jobs and

Multi-Process Jobs at any time within the **Processing** tab, without having the main Automation Manager node selected as the new job buttons are now always active. The new functionality has been added to both tree lists (processing and contents).

If a customer node is selected, the new job will be created for that customer; otherwise, the job will be created at the end of the tree.

Old Behaviour:

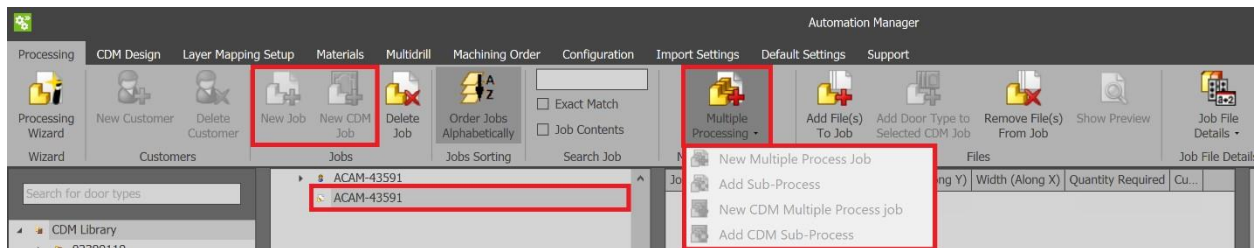

New Behaviour:

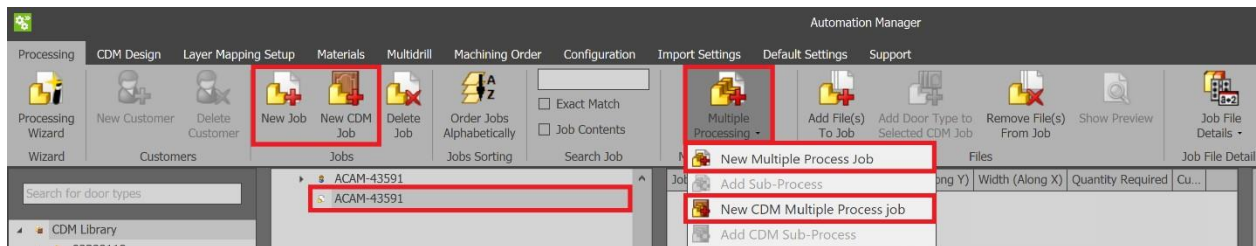

Automation Manager - Longest Edge and Vector Alignment - Improve UI with drop-down menus

The **Align Longest Edge With X Axis** and **Align Vector With X Axis** check box fields have been renamed and replaced with drop-down menus. These options become visible when the **Auto Alignment** option is active within the **Solid Alignment Settings** of a Layer Mapping Setup.

- **Align Longest Edge With X Axis** has been renamed to **Align Longest Edge With** and the checkbox has been replaced with a drop-down menu containing the **Align Longest Edge With X-Axis** and **Align Longest Edge With Y-Axis** options.
- **Align Vector With X Axis** has been renamed to **Align Vector With** and now has a dropdown menu with the **X-Axis** and **Y-Axis** options.

The default option for any new setup will remain as the **Y-Axis**.

Solid Alignment Settings	
Auto Align Part	<input checked="" type="checkbox"/>
Datum Point X	Left
Datum Point Y	Bottom
Datum Point Z	Bottom
Use Panel Alignment	<input checked="" type="checkbox"/>
Align Longest Edge With	Align Longest Edge With Y-Axis
Align Vector With	Y-Axis
Use Minimum Bounding Box Alignment	<input type="checkbox"/>

Nesting

Nesting - Support for Saving Sheets in Nest Lists

Nest List data files (*.anl) can now, optionally, include sheet information. A new **Save NestList with Sheets** option has been added to the right-click menu in the Nesting project manager page.

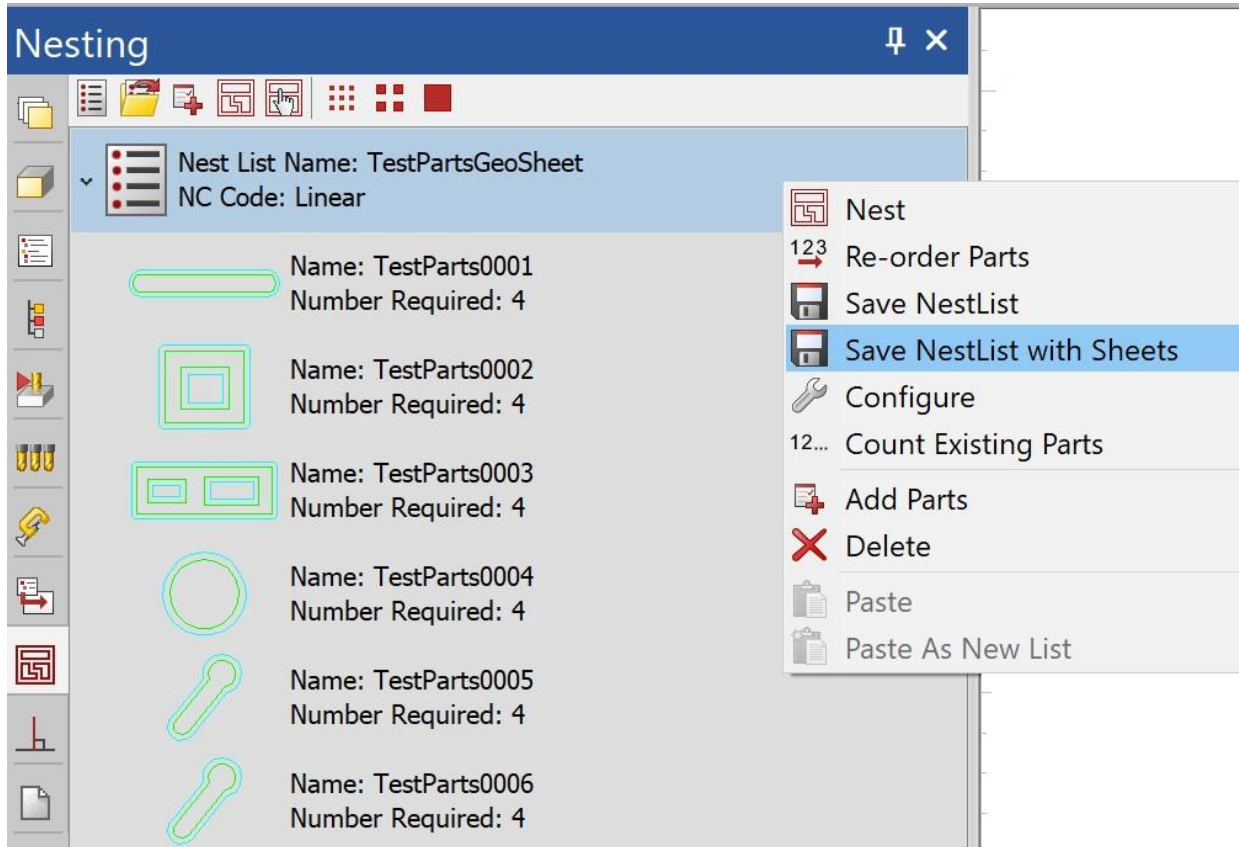

The **Save NestList with Sheets** option becomes available when the Nest List has been assigned one or more sheets. The sheets can be picked from a Sheet Database or from geometry in the Drawing:

- For sheets picked from a Database, the ID of the sheet is saved in the Nest List. When the Nest List is loaded into ALPHACAM later, that sheet must exist in the Sheet Database; otherwise, a warning message will be displayed.
- For sheets picked from the Drawing, the profile of the sheet and the profiles of any Small Part or No Nest Zones are saved into the Nest List file. When the Nest List is loaded into ALPHACAM later, the sheets and zones will be constructed from their profiles.

The ability to save sheets has also been added for Nest Lists which are using parts selected from the Drawing. A new **Export NestList, Parts and Sheets** right-click menu option has been added in addition to the existing **Export NestList and Parts** option.

Nesting - Quick Nest Geometries - Support for the Advanced Nesting Engine

The **Quick Nest** add-in has been updated to use the **Advanced Nesting** engine instead of the **Trueshape** or **Original Nester** engines which have both been removed. The **Rectangular Nesting** engine is still available:

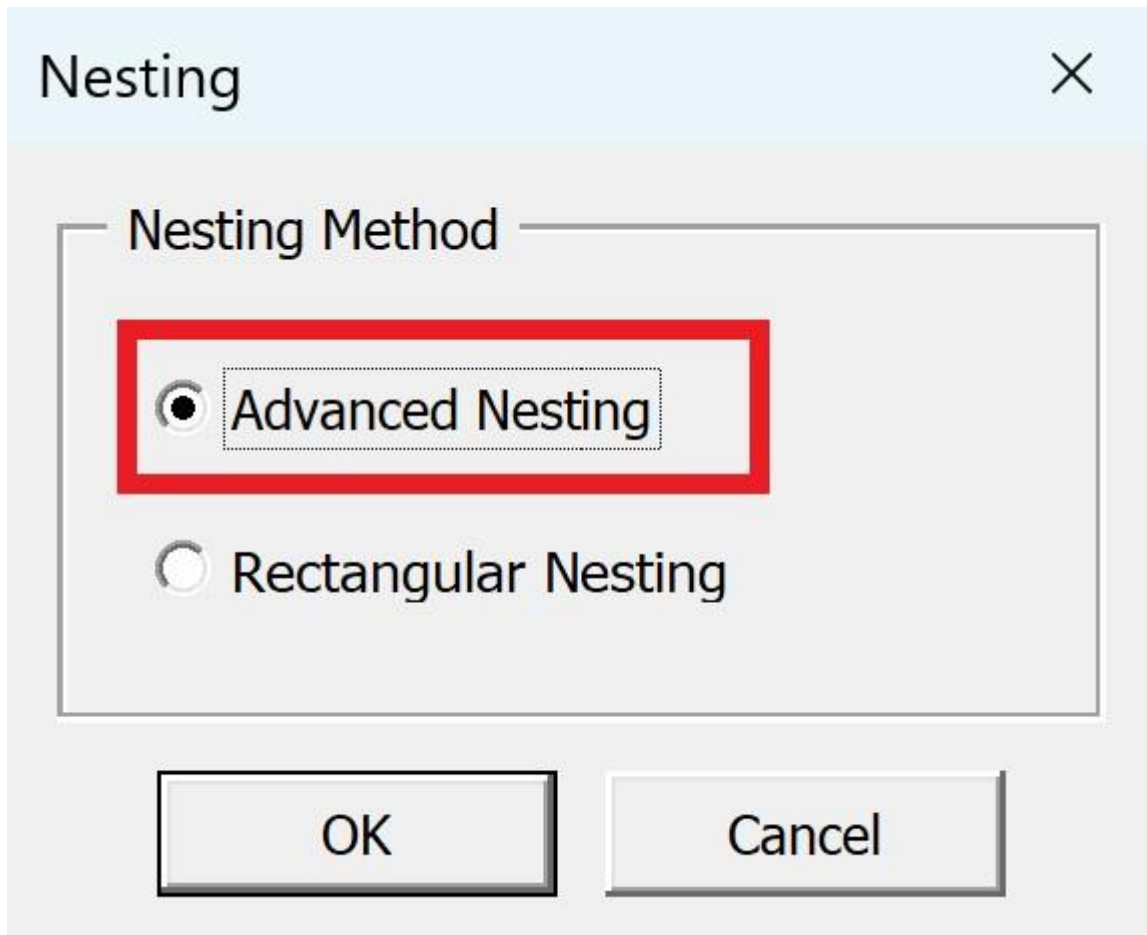

After following the prompts to select closed Geometries and selecting the Sheet Geometry from on screen, an updated **Nesting Parameters** dialog will open. A new **Maximum Possible** option has been added to the **Number Required** selection and **Kit Number** support has also been added:

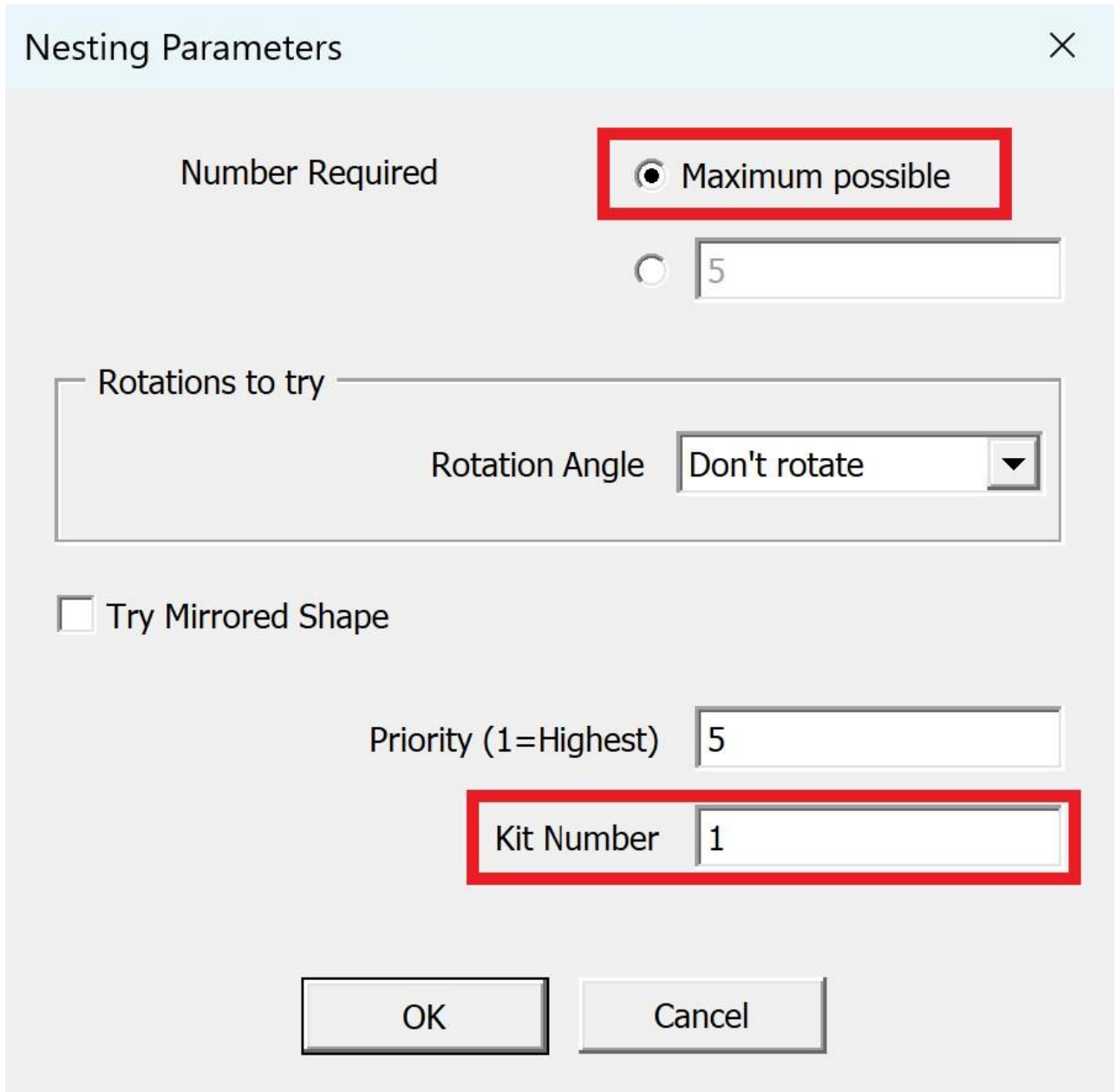

Nesting Parameters

Number Required

Maximum possible

5

Rotations to try

Rotation Angle Don't rotate

Try Mirrored Shape

Priority (1=Highest) 5

Kit Number 1

OK Cancel

After the number of required parts etc. has been defined and **OK** is pressed, a new dialog is displayed where the nesting settings can be applied. Once **OK** is pressed on this dialog, nesting will start:

Nesting Parameters ✕

Pack to

Top-Left Top-Right

Bottom-Left Bottom-Right

Offcut Preference

Vertical Offcut Horizontal Offcut

Spacing

Minimum Gap between Paths

Gap at Sheet Edge

Evenly Spaced Parts

Processing Time

Total Computation Time

Inactivity Timeout

Options

Suppress Drawing of Duplicate Sheets

Force strict Part priorities

Configuration

Configuration - Customisable default colour for Clamp/Fixture Layers

The **Colours** property dialog in **General** settings, which is accessed using the **Configure** button in the **Home** tab of the ribbon, has been expanded to include a default colour for **Clamps and Fixtures**. The new colour is used whenever a new Clamp/Fixtures layer is added to the Drawing (or a Machine). The new colour will be saved in the registry and can be exported into a settings file.

The new colour defaults to Grey (RGB 192,192,192) but can be modified by the user.

i

Any existing drawings with clamps or fixtures will not adopt the new colour; only newly created Clamp/Fixture layers will use the new default.

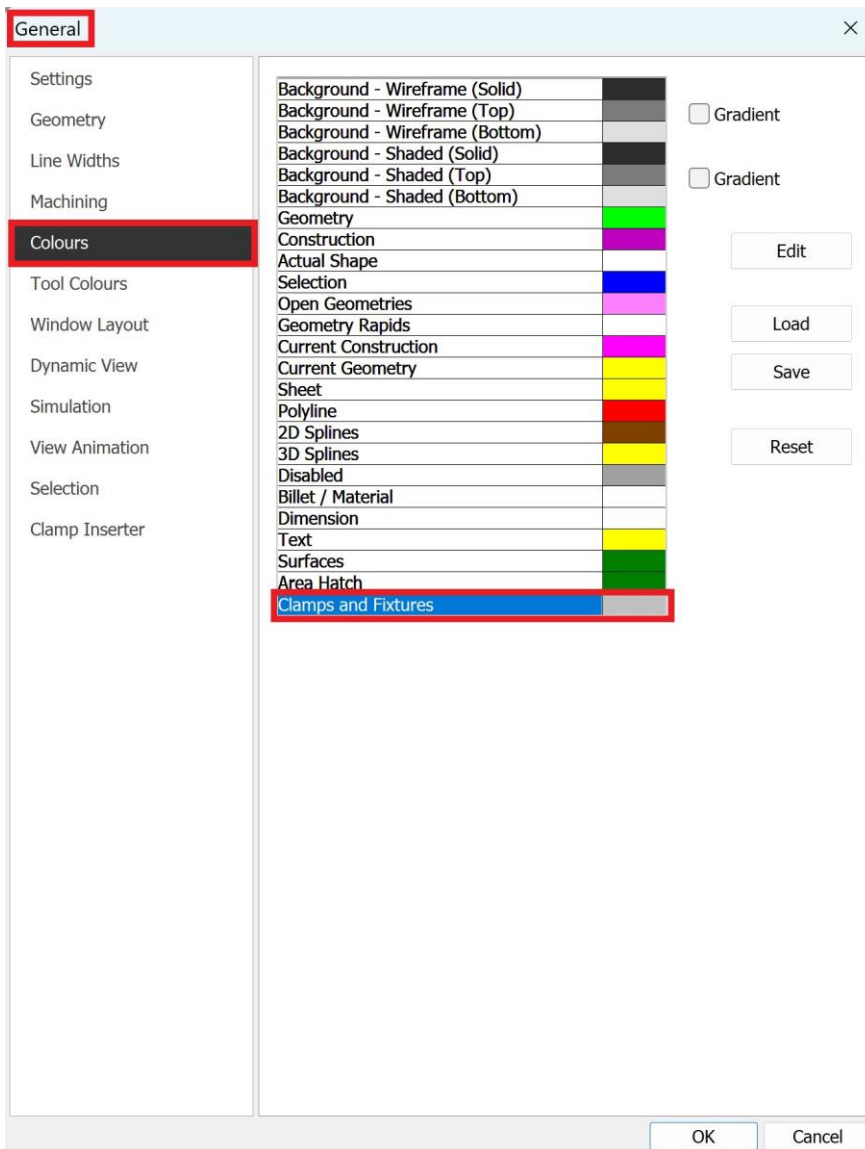

The screenshot shows the 'General' settings dialog box with the 'Colours' tab selected. The 'Clamps and Fixtures' color is highlighted in blue. The dialog box contains a list of settings with corresponding color swatches and checkboxes for 'Gradient'.

Setting	Color	Gradient
Background - Wireframe (Solid)	Dark Grey	<input type="checkbox"/>
Background - Wireframe (Top)	Light Grey	<input type="checkbox"/>
Background - Wireframe (Bottom)	Light Grey	<input type="checkbox"/>
Background - Shaded (Solid)	Dark Grey	<input type="checkbox"/>
Background - Shaded (Top)	Light Grey	<input type="checkbox"/>
Background - Shaded (Bottom)	Light Grey	<input type="checkbox"/>
Geometry	Green	
Construction	Purple	
Actual Shape	Blue	<input type="button" value="Edit"/>
Selection	Blue	
Open Geometries	Pink	<input type="button" value="Load"/>
Geometry Rapids	Pink	
Current Construction	Magenta	<input type="button" value="Save"/>
Current Geometry	Yellow	
Sheet	Yellow	
Polyline	Red	
2D Splines	Brown	<input type="button" value="Reset"/>
3D Splines	Yellow	
Disabled	Grey	
Billet / Material	White	
Dimension	White	
Text	Yellow	
Surfaces	Green	
Area Hatch	Green	
Clamps and Fixtures	Blue	

Reports

Reports - Nested Part Position Image

A new **Nested Part Placement Images** option has been added in the **Report Data Settings** dialog to assist in locating the correct part to which a label is to be applied.

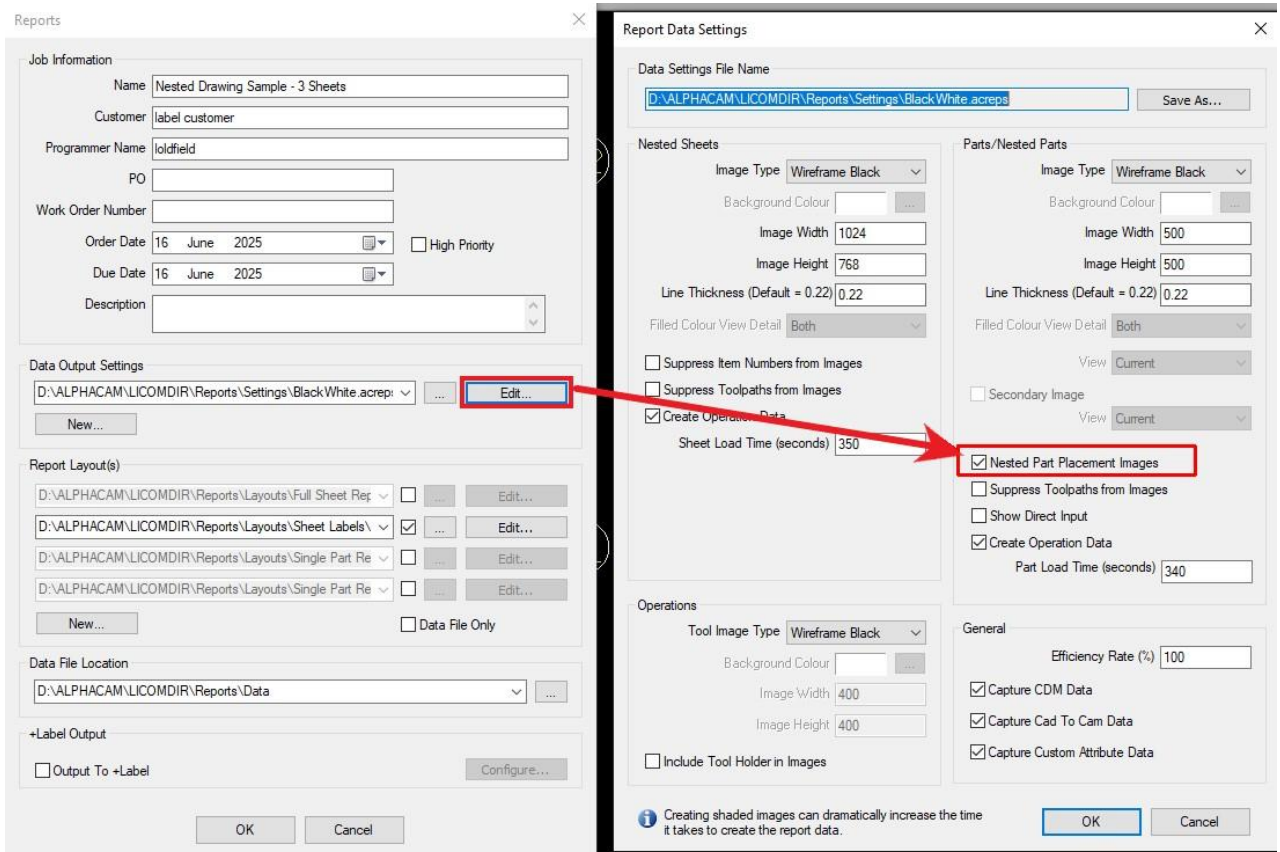

A new **Nested Part Placement Image** field has been added within the Reports Designer (Nested Sheet Data – Parts in Nested Sheet). When checked, an image will be created for each part in the nested result, showing where the part is located on the sheet:

ALPHACAM by HEXAGON		Job: Nested Drawing Sample - 3 Sheets	
		Customer: label customer	
		PO:	Due: 06/16/2025
Sheet A1			
Material: MDF			
Width: 2440			
Length: 1220			
Thickness: 19			
CycleTime (H:M:S): 0:12:48			
Scrap %: 14		Control's boundaries are too small for the barcode	
Part Name:	Part Index:	Qty in Sheet:	Part Image:
AM_NestDoor_45Angled_1	1	1	
AM_NestDoor_DrillingTest_3	3	3	
AM_NestRect350x700_18	18	1	

Four new sample reports are now included in the ALPHACAM 2025.2 version and will be added to the LICOMDIR folder.

- LICOMDIR\Reports\Layouts\Full Sheet Reports\A4 (Metric)\Nested_Job_Sheet_Part_Report_BW_WithPartPlacementImage.acrepx
- LICOMDIR\Reports\Layouts\Full Sheet Reports\Letter (Imperial)\Nested_Job_Sheet_Part_Report_BW_WithPartPlacement.acrepx - New sheet labels reports:
- LICOMDIR\Reports\Layouts\Sheet Labels\A4 (Metric)\100x30_Sheet_Parts_wBarcode_PartPlacement.acrepx
- LICOMDIR\Reports\Layouts\Sheet Labels\Letter (Imperial)\4x1.33_Sheet_Parts_wBarcode_BW_WithPartPlacement.acrepx

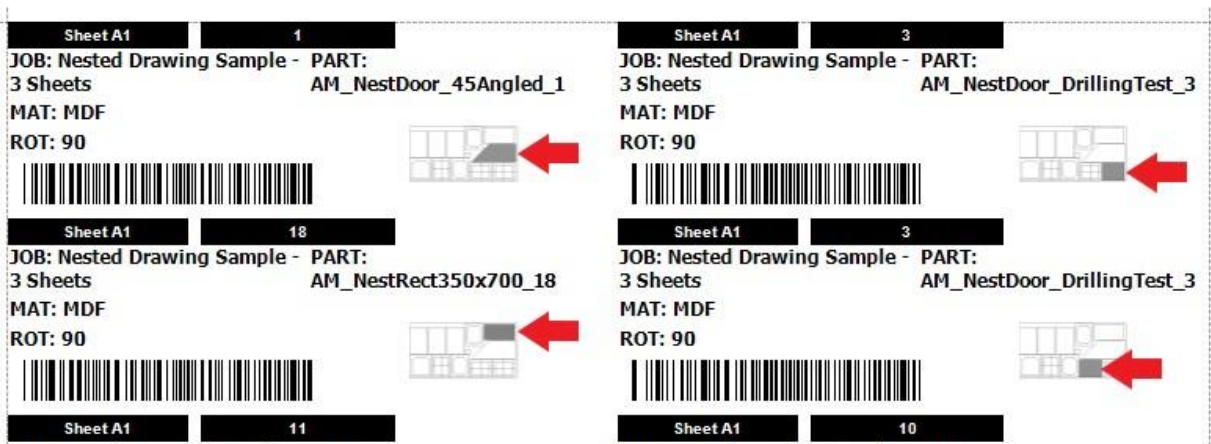

Release Notes 2025.1

Maintenance Report

The following is a list of bug fixes and enhancements implemented in ALPHACAM 2025.1:

ID	Description	Closing Notes
4959	Lathe - Move Developed Diameter from Solid Model Face from the 3D tab to the Work Planes tab.	Implemented.
5157	Automation Manager - Sheet Database - Order Sheets by Thickness.	Implemented.
6306	Edit - Join - When a box selection is made of geometries on multiple layers, the layers are lost.	Improved.
20824	Quick Edit - Advanced 5 Axis - Renamed operations revert after updating.	Fixed.
20835	Automation Manager - When a sheet has grain directions set to None, parts do not have free rotation.	Fixed.
20948	3D Machining - Work Planes - New plane created when operation is updated.	Fixed.
28111	Edit Text - True Type Font cannot be edited unless a change to the original text is made.	Fixed.
28993	Add-Ins - Inventor Input (Surfaces) – Remove.	Removed.
33069	Edit Text – True Type Font Paste / CTRL + V fails.	Fixed.
35211	Nesting - Renesting geometry-only parts creates a gap which is too small between new and old parts.	Fixed.
35708	Advanced 5 Axis - Gap/stock left when there should be none.	Fixed.
36951	Automation Manager - Layer Mapping Setup - Include Flat Areas as Additional Z-Levels is active even if Z level Step is set to 0.	Fixed.
38948	GUI - Machining Dialogs not releasing GDI objects.	Fixed.
39066	Project Manager - Operations - Find Next stopped working.	Fixed.
39182	GUI - Layers - Move Up / Down buttons deselect moved item.	Fixed.
39571	Automation Manager - Grain direction align problem.	Fixed.
40126	Solid Simulation - Improve export of machined stock back to ALPHACAM as material/STL.	Improved.
40839	Automation Manager - Deleting multiple files using Delete key asks to Process the Job.	Fixed.
41050	Automation Manager - Stop selecting Root Node when deleting entities.	Implemented.
41157	Aspire - Update to V12.	Implemented.
41203	Add-ins - BXF Translator – Remove.	Implemented.
41204	Add-Ins - Z Level Preview - Remove and place in examples folder.	Implemented.
41205	Add-Ins - CSV File Utility - Remove and place in API examples.	Implemented.
41206	Add-Ins - Move PolyLines To a User Layer - Remove and place in API examples.	Implemented.
41207	Add-Ins - Duplicate Surface finder - Remove and place in API examples.	Implemented.
41272	Display Options - Show Open Geometry should not affect Polylines.	Fixed.
41389	Solid Simulator - Different simulation speeds in different modes.	Fixed.
41510	Combined Pocketing - Attribute LicomUKDMBOperationNote is not set on the Cut Path toolpaths.	Fixed.
41527	Automation Manager – Unhandled Exception when clicking on Job Defaults if XNesting is disabled.	Fixed.

41538	Drawing Notes - Images are not saved if the note only contains an image.	Fixed.
41544	Solid Simulation - Some operations are not shown correctly when 'Safe Rapid' and 'Rapid down to' have the same values.	Fixed.
41558	Automation Manager - Nesting Settings visible without xNesting.	Fixed.
41559	Automation Manager - Assembly Handling Options visible when xSolids is not available.	Fixed.
41717	Automation Manager - Import Settings - Using Delete key to delete import setting fields causes Unhandled Exception.	Fixed.
41729	Folder Watcher - Processing more than one Assembly asks to clear Drawing.	Fixed.
41730	Drawing Notes - Unresponsive after drag and drop image.	Fixed.
41731	Solid Simulation/3D - Material creation to ignore Dimension and Construction geometry.	Implemented.
41732	Automation Manager - Search Job Contents - Disable search filter when no Job is selected.	Implemented.
41934	Automation Manager - Keyboard delete in drop-down menus causes Unhandled Exception.	Fixed.
42030	Solid Simulation - Rapid speed for Drill holes is not correct in Solid Simulation.	Fixed.
42064	Drawing Notes - Open with Drawing Notes if Found only works in the currently active session.	Fixed.
42077	Project Manager - Set Materials - Refresh does not apply.	Fixed.
42078	Advanced 5 Axis - Taper Mill with Corner Radius geometry profile is incorrect.	Fixed.
42094	Advanced 5 Axis - Barrel Mill - Taper tool geometry profile is incorrect.	Fixed.
42108	Add-ins - Input Fast Track – Remove.	Implemented.
42109	Add-in - Scale Z Levels - Remove and put in examples folder.	Implemented.
42110	Add-ins - Auto Geometry Bridge - Remove and put in examples.	Implemented.
42160	Automation Manager - CSV Import - Enforce Configuration is selected.	Fixed.
42175	Line Properties - Layers Manager does not refresh.	Fixed.
42201	Tool Data Sync - Slow to open when Machining Styles Manager is open.	Fixed.
42237	API - UserGet2DPointWithCallback - Missing geometry and toolpaths when zooming out.	Fixed.
42270	API - UserGet2DPointWithCallback - Not working when called from C# add-in custom operation functions.	Fixed.
42290	Advanced 5 Axis - Dove Mill with Corner Radius geometry profile is incorrect.	Fixed.
42291	Advanced 5 Axis - Chamfer Mill, Full Radius with Cylinder + Cone shaft geometry profile is incorrect.	Fixed.
42294	Integrate CLS 2025.1.	Implemented.
42297	Project Manager – Layers – Renaming Solids causes ALPHACAM to Crash.	Fixed.
42438	Solid Simulation - Black edges on Materials.	Fixed.
42440	Solid Simulation - Improve inactive Rapid speed slider.	Implemented.
42492	Integrate NCSIMUL 2025.1.	Implemented.
42585	GUI - Background colour of Machining dialogs is not white on Windows 11.	Fixed.
42602	Nesting - Preserve Frame.AllowModifyingCommands state.	Fixed.
42611	Solid Simulation - Incorrect Aggregate orientation.	Fixed.
42626	Path.TrimWithCuttingGeos change in behaviour for non-intersecting geometries.	Fixed.

42648	Operations Project Page - Change Tool appears in pop-up menu twice for add-in operations.	Fixed.
42788	Solid Simulation - Remember Speed slider lock state.	Implemented.
42789	Remove Sentinel System Driver from installer.	Implemented.
42909	Create Surface - Flat Surface creation improvement.	Fixed.
43075	Post Processor - WRZ Array Variable not working.	Fixed.
43198	Shop Floor Editor - Simulation - Incorrect icons used for commands.	Fixed.
43200	Installer - Korean language has question marks throughout the installation dialogs.	Fixed.

Whats New

Rough or Finish

Rough or Finish - Cycle renamed to Cut Path

For Router, Mill and Lathe: **Rough or Finish** is now **Cut Path**.

For Stone, **Cut Shape** is now **Cut Path**.

In the Operation tree and NC Output:

- **ROUGHING PASS** is now **CUT PATH - ROUGH**.
- **FINISH PASS** is now **CUT PATH - FINISH**.
- **HELICAL ROUGHING PASS** is now **HELICAL ROUGH PASS** for consistency.

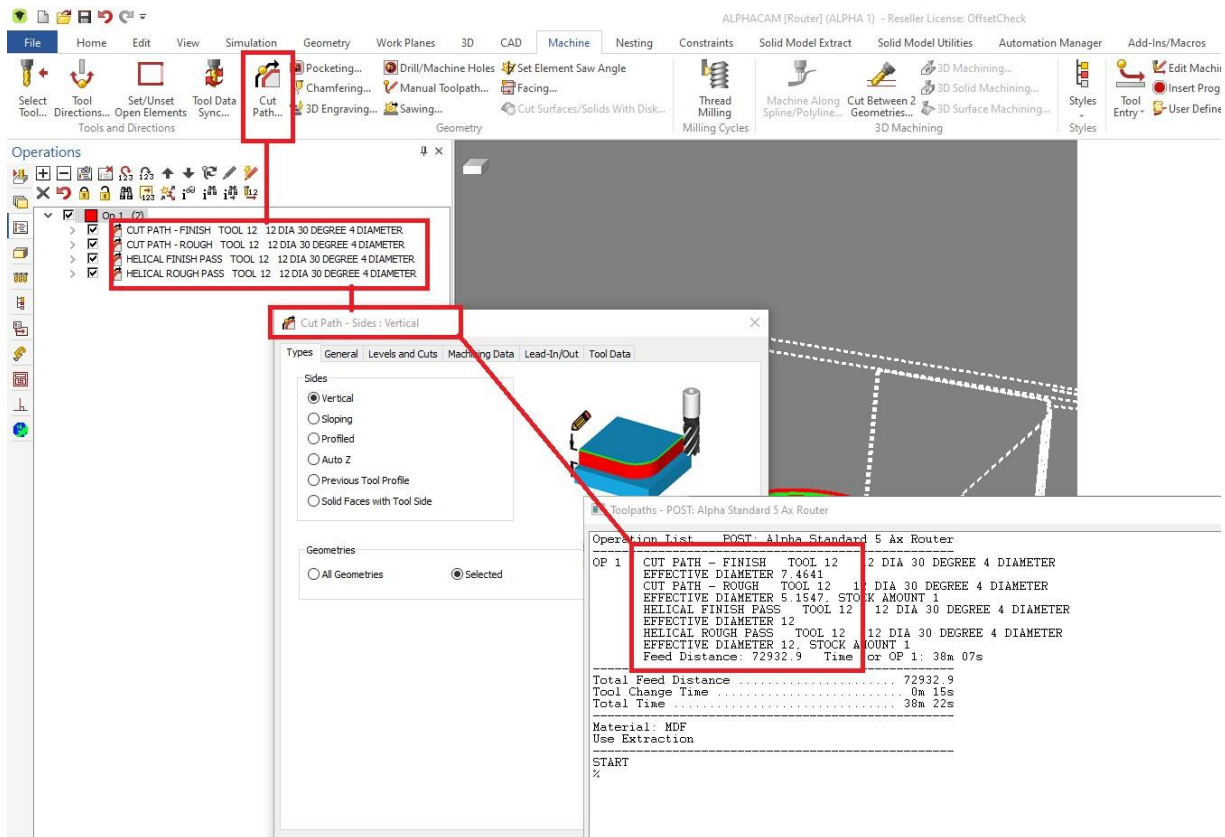

Advanced 5-Axis

Advanced 5-Axis – Updated to newest libraries

The Advanced 5-Axis machining software libraries have been updated to include new features, improvements and bug fixes, some of which are highlighted in the following sections.

	Some options have been relocated on the dialogs.
---	--

Tools

- New user-defined shaft profile allows the user to define the contour of the shaft.
- Slot Mill tools can now be defined with chamfered edges.
- Barrel Mill Tangent to conical shaft adds a flatness diameter parameter.
- Barrel Mill Tangent to shaft also adds a flatness diameter parameter.

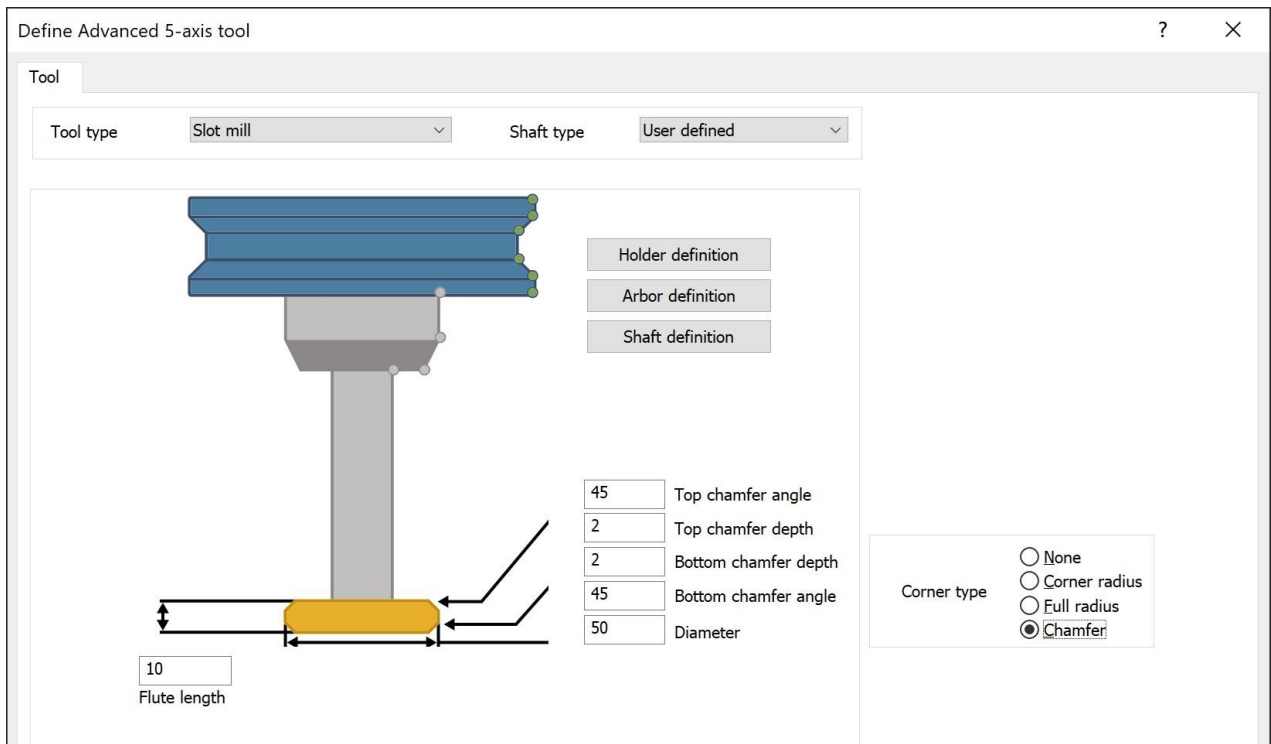

Define Advanced 5-axis tool

Tool type: Slot mill Shaft type: User defined

Holder definition
Arbor definition
Shaft definition

45 Top chamfer angle
2 Top chamfer depth
2 Bottom chamfer depth
45 Bottom chamfer angle
50 Diameter

10 Flute length

Corner type: None Corner radius Full radius Chamfer

Multi-Axis Roughing Cycle

- In the **Part Definition** tab, you can now pick surfaces or faces representing fixtures to avoid when machining the part.
- New Tool axis controls, including the ability to define a fixed tool axis.
- Ability to provide a user defined clearance surface.

Surface Machining

- Specify a user-defined tool orientation on Lead In/Out moves.
- New feed control zone blending parameter defines the blending distance around the Feed Control Zone. This ensures a smooth feed rate transition to avoid abrupt accelerations and decelerations.
- The Flowline pattern direction can now be set to the parametric directions (U of V) of the given surface.

Swarf Machining

- Tilting strategies use a new algorithm which ensures more consistent results even in difficult scenarios.
- Gouge checking against individual tool parts has been added to the **Gouge Check** tab in the **Avoid by relinking/retracting** sections.

Backwards compatibility removed

- Due to the increasing complexity of this machining library, ALPHACAM can no longer provide backwards compatibility for operations created using the Advanced 5-Axis cycles. This means that you cannot use the **Save As** command to save an ALPHACAM 2025 Drawing into an older Drawing file format if it contains Advanced 5-Axis cycles.
- Advanced 5-Axis tools using the new user-defined shaft type cannot be used in older versions of ALPHACAM. Tools using this shaft-type will not appear in the tool library for older versions of ALPHACAM.

Existing 5-Axis Advanced tools

- While integrating this latest set of libraries, some problems were identified with the geometry profile created with certain tools. The geometry profiles are used to visualise the tools inside ALPHACAM. The toolpaths themselves and the NC code generated were correct. The problem was that the shape of the tool, as seen in the ALPHACAM tool library, was incorrect. This also meant that simulation was inaccurate because the simulator also uses the geometry profile to define the tool.
- If you edit or update an Advanced 5-Axis operation using a tool with an incorrect geometry profile, a warning message will be displayed. A similar warning message will be displayed if you select a tool with an incorrect geometry profile from the tool library. To fix the problem, the tool should be edited and re-saved. There is no need to change any parameters, just re-save the tool and the geometry profile will be regenerated correctly. There are four tools with specific features which have this problem:
 - Taper Mill using a defined corner radius.
 - Dove Mill using a defined corner radius.
 - Chamfer Mill using a full radius corner type and a 'Cylinder + Cone' shaft type.
 - Barrel Mill Taper type.

Existing Barrel Mill tools using cylindrical shafts

- Another problem was identified relating to some Barrel Mill cutters where a 'Cylinder' shaft type was being saved as 'Cylinder + Cone' instead. Unfortunately, it is not possible to determine whether the intended shaft type was 'Cylinder' or 'Cylinder + Cone' and, therefore, no warning message can be displayed. Editing the tool and picking the correct shafttype, verifying the shaft diameter is correct and re-saving the tool will resolve the issue. It is highly recommended that you check any of the following Barrel Mill types to confirm whether the shaft-type is set correctly:
 - Barrel Mill Advanced.
 - Barrel Mill Lens.
 - Barrel Mill Taper.
 - Barrel Mill Double Profile.
 - Barrel Mill Section.

Lathe

Lathe - Add Face Milling / Facing to C Axis machining

The Face Milling cycle in Milling, Router and Stone Modules has now been added to the Lathe Module. C and Y axis are supported dependent on the xPositional add on.

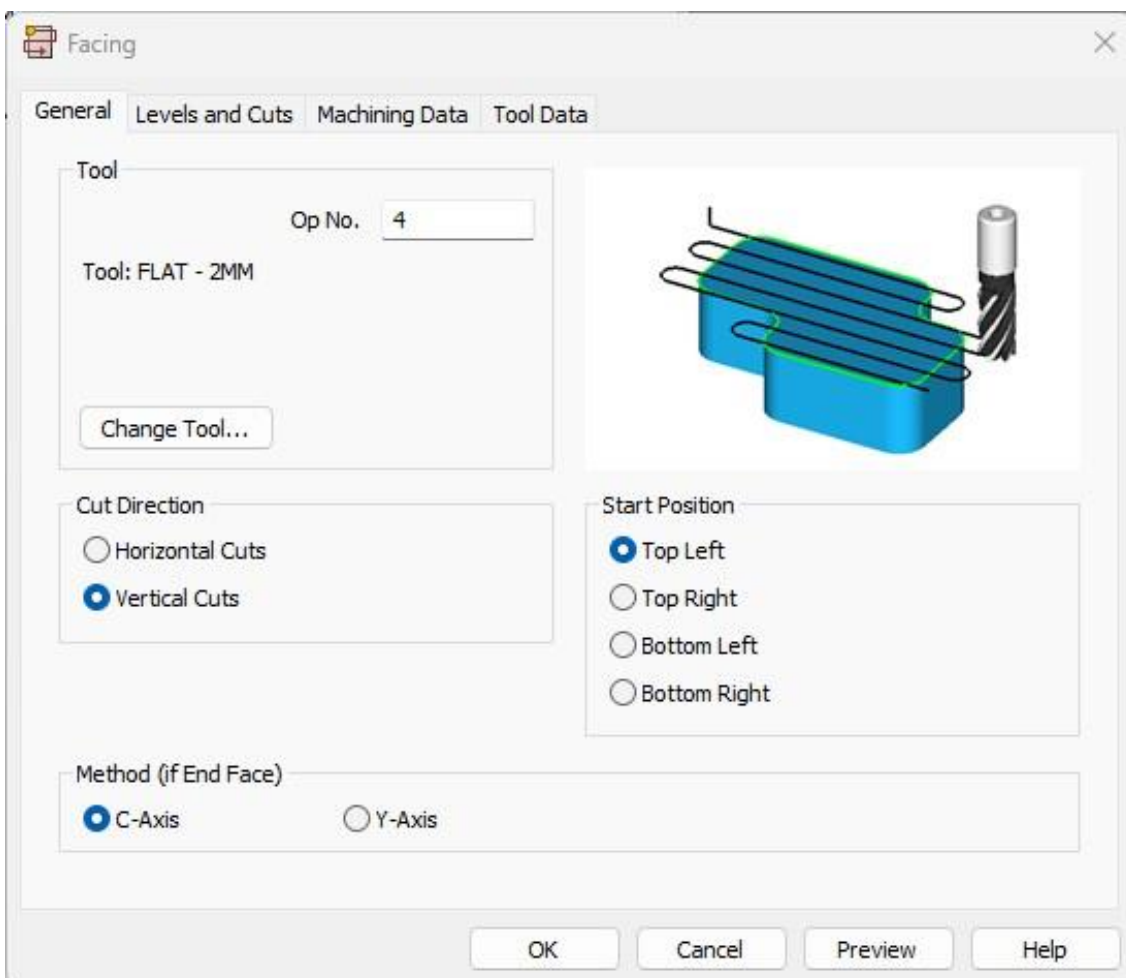
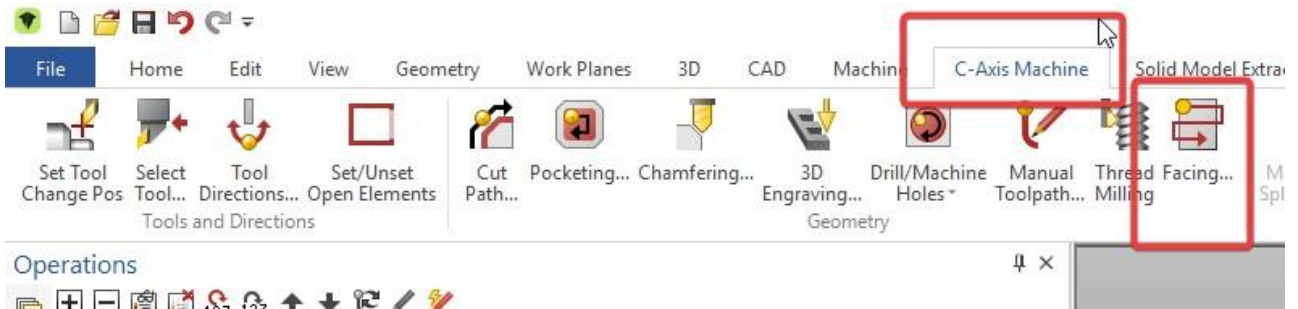

Lathe - Show tool tip radius in the Tool Data tab of the Machining Dialogs

The **Tool Data** tab for Lathe turning operations has been updated to include the Tool **Tip Radius** for Turn tools. For machining cycles such as Centre Line Drilling, the diameter of the tool will be displayed instead, because the tool is a Mill tool and not a Turning tool.

The Tool **Tip Radius**/Tool **Diameter** control is read-only so that the user can see a tool tip and copy the value from the edit box.

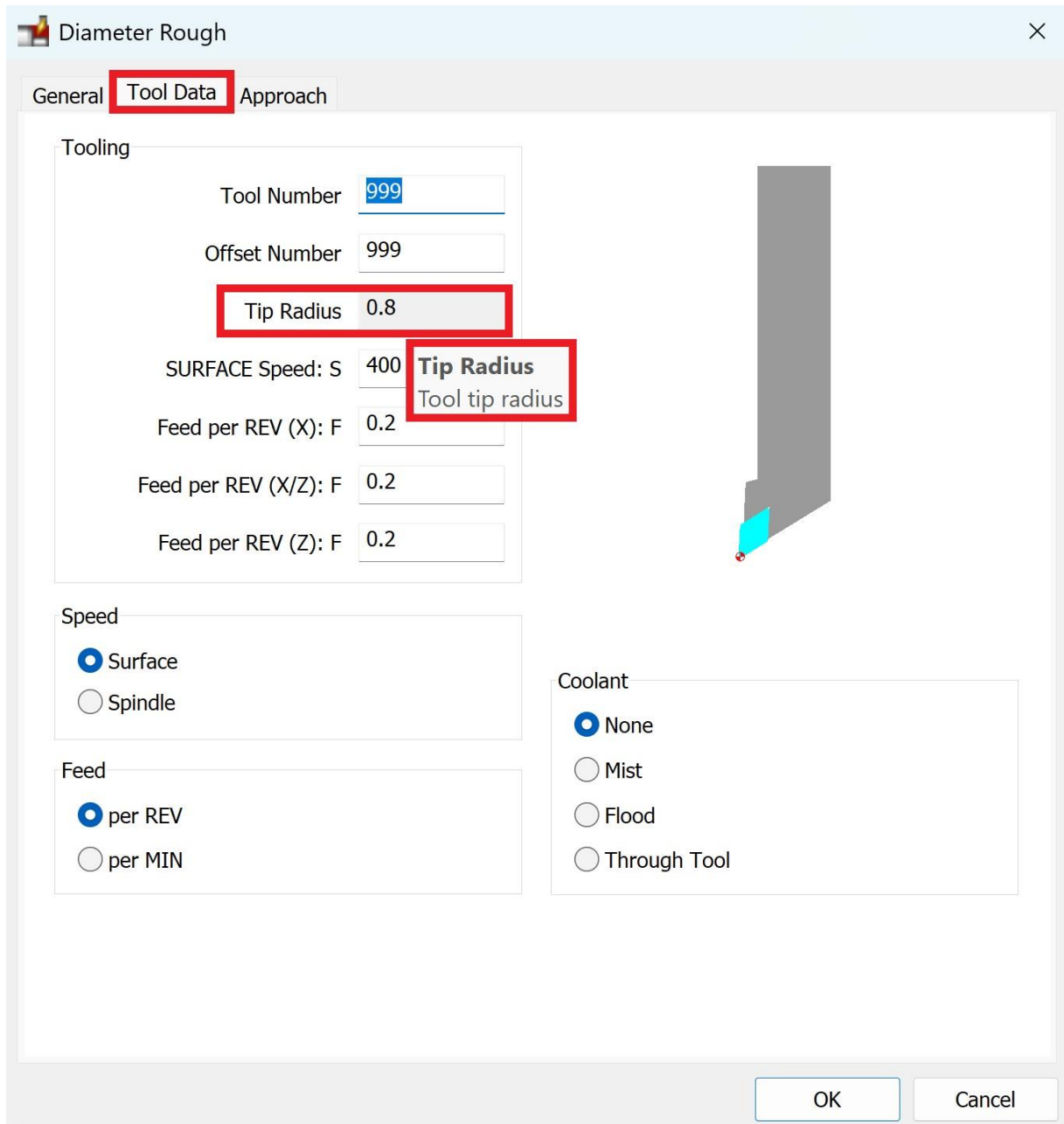

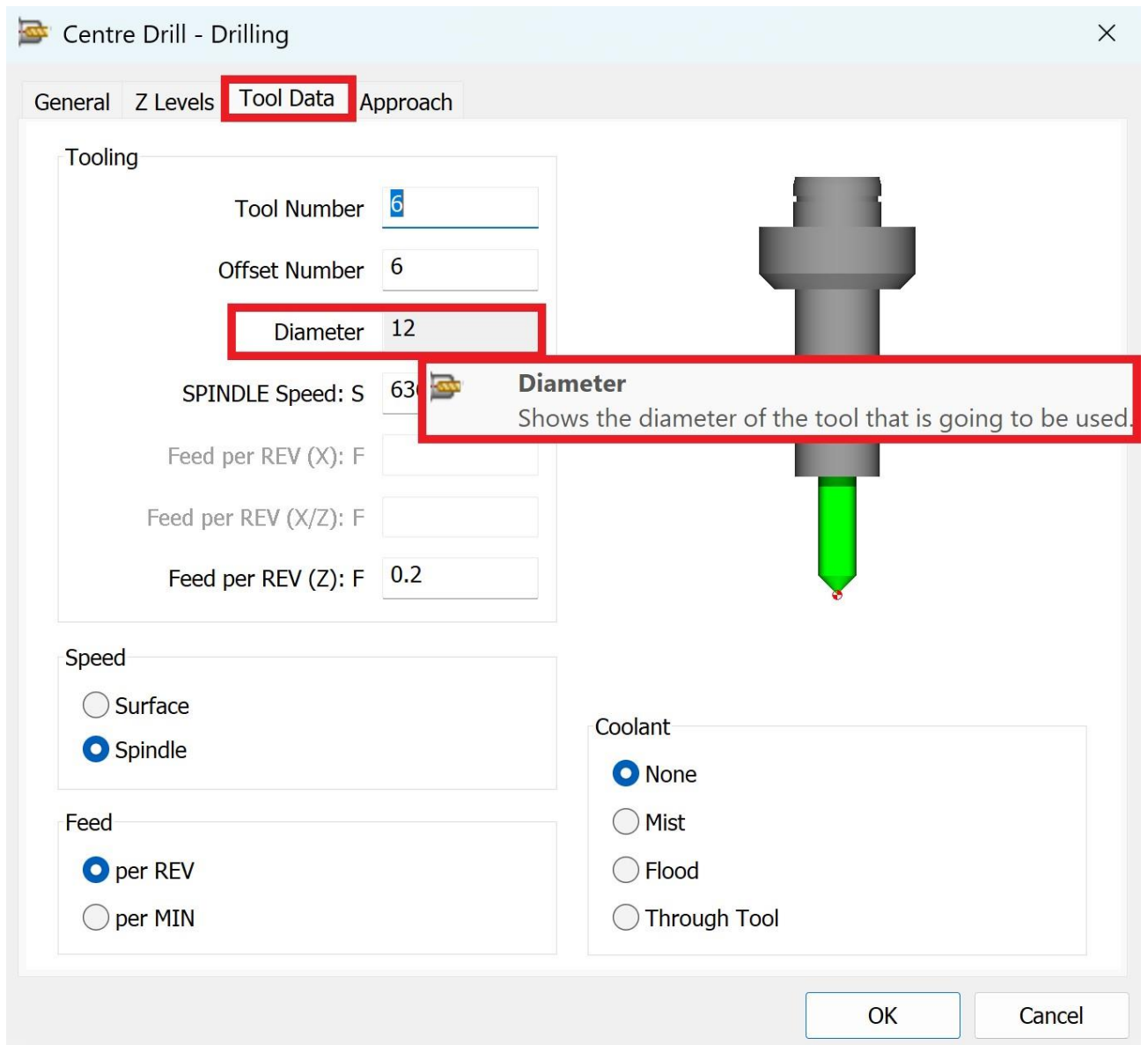

Sawing Toolpaths

Sawing Toolpaths - Display Options - Draw Saw Head Position

A new **Draw Saw Head Position** Display Option has been added for this release which is only visibly active in XY view with no active work plane:

- Shows a marker representing the saw with a motor/head on the correct side. The saw part of the marker is the actual size of the saw.
- Supports vertical, horizontal and angled saw toolpaths.
- Supports line-only, line and arc ('Include Arcs') and 'Internal Arc' sawing toolpaths.
- The marker is shown at the start of the first horizontal cut for each toolpath (i.e. after the initial down feed) and, in the case of angled saw-cuts, it is positioned to be where the saw intersects the Material Top.

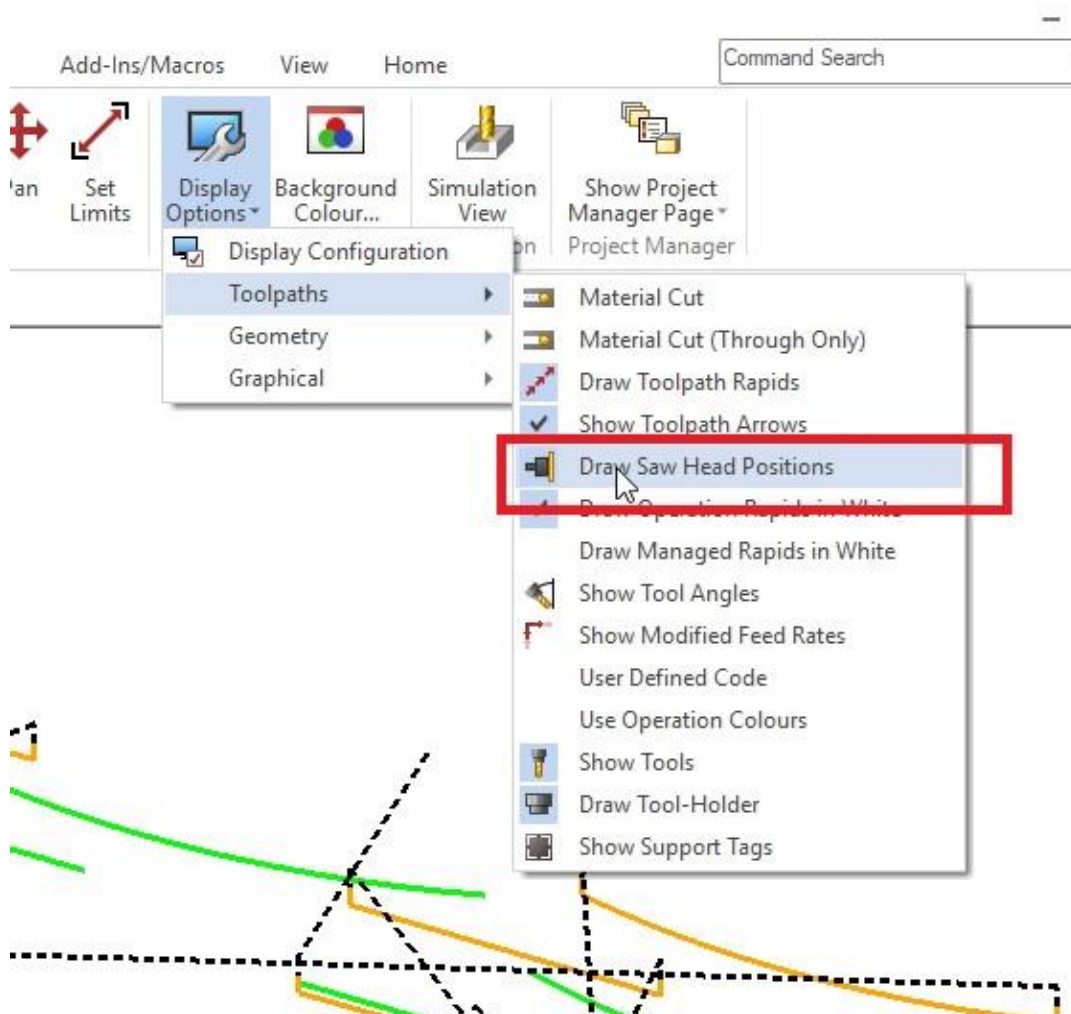
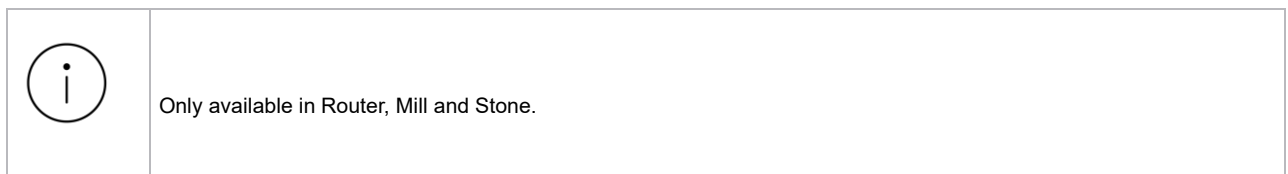

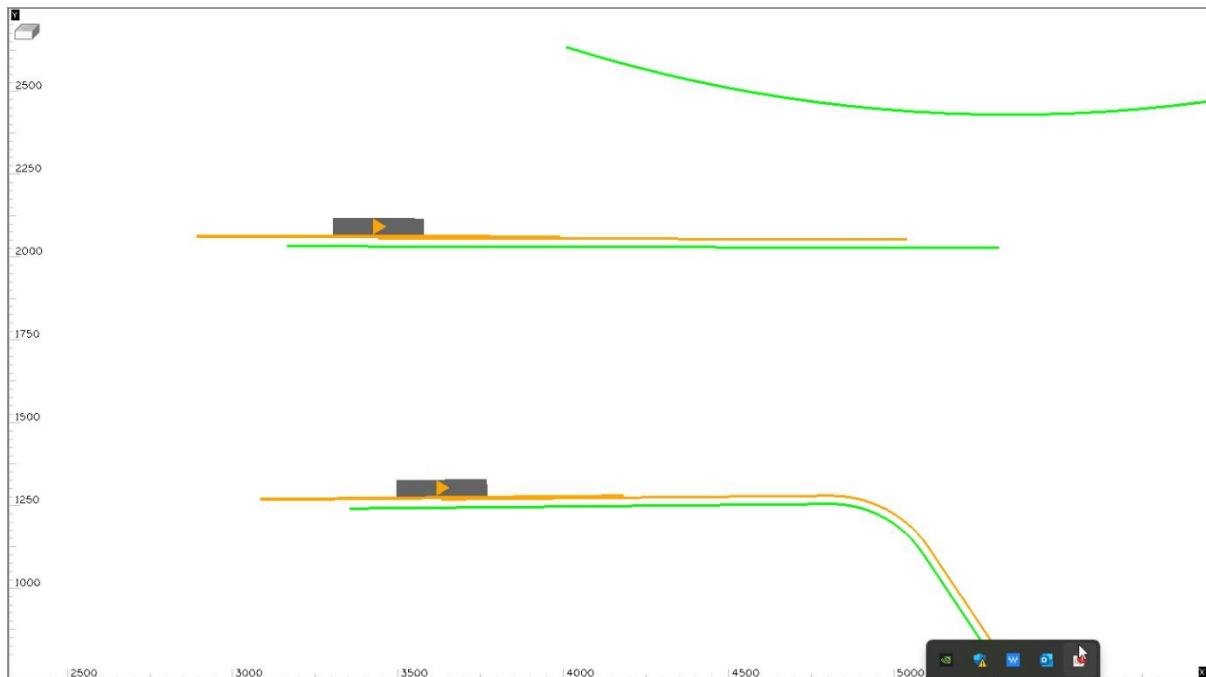

Solid Simulation

Solid Simulation - Use actual Tolerance

The tolerance displayed in the Simulation tab of the Project Manager is now the tolerance that is used by both the old Solid Simulator and the new Solid Simulator.

Additionally, the default tolerance calculation has been changed. Previously, if a tolerance of 0.1 was produced, it will now be 0.2.

The default tolerance is now the diameter of the smallest tool/100.

Solid Simulation - Stone - Guards - To be positioned relative to the Gauge Line

Guards are now fixed relative to the green gauge point at the top of the tool rather than the red point at the tip.

Changing the Tool length, holder type or holder length of an existing tool will now maintain the guard at a fixed distance from the top. This is the same for newly created tools with a guard defined.

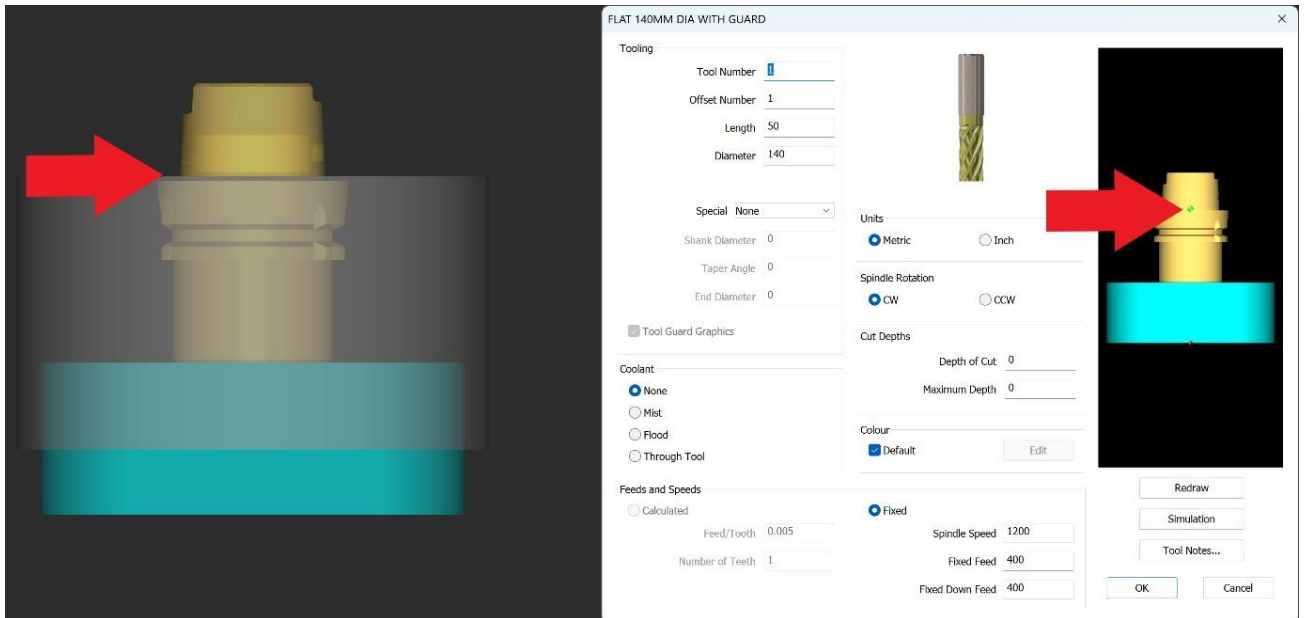

Solid Simulation - Support sending of parts

Any solid with the **Set as Simulator Part** flag set from the right click context menu of the Layers tab, will now appear in Solid Simulation. Selecting or deselecting the check box next to solid in the Layers tree will make the part visible or invisible in Solid Simulation.

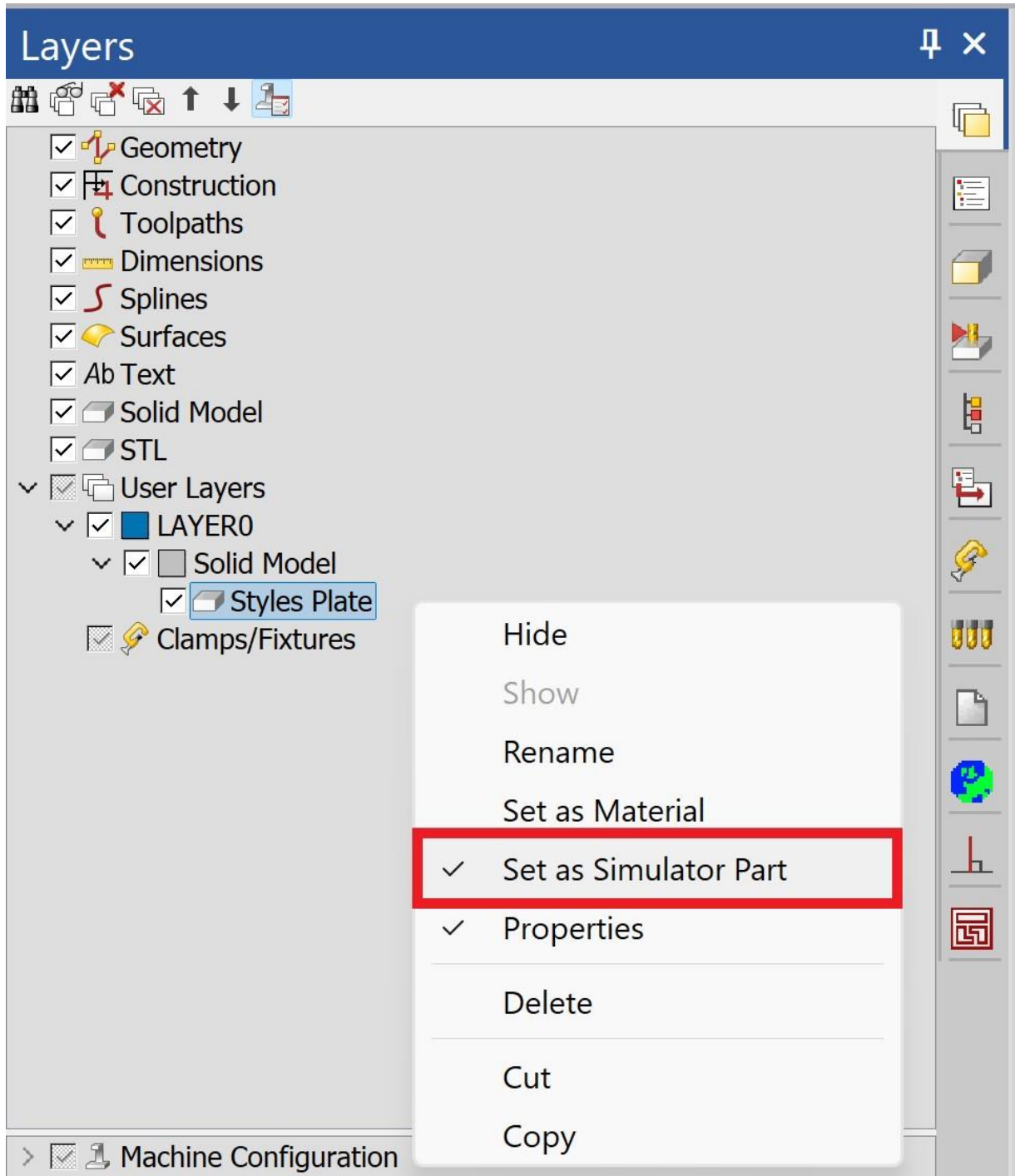

Solid Simulation - Speed Sliders - New Lock/Combine sliders Button

A new **Lock/Unlock** button has been added to the simulation sliders. When locked, the sliders for Feed and Rapid are combined into one **Speed** slider and the **Rapid** slider is disabled. The speeds for Feed and Rapid are, therefore, increased or decreased simultaneously. When unlocked, they behave independently as previously.

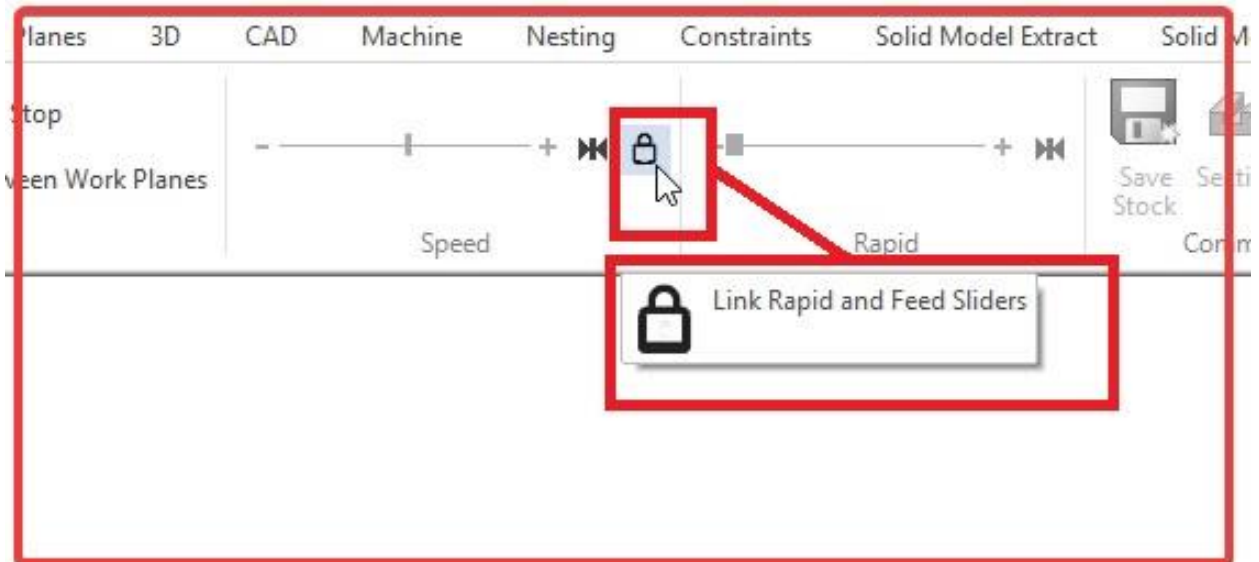

Solid Simulation - Report Distance/Angle

The **Distance/Angle** command has been added to the **Simulation** tab within the **Commands** group. The command works in the same way as the **Distance/Angle** command located in the **CAD** tab.

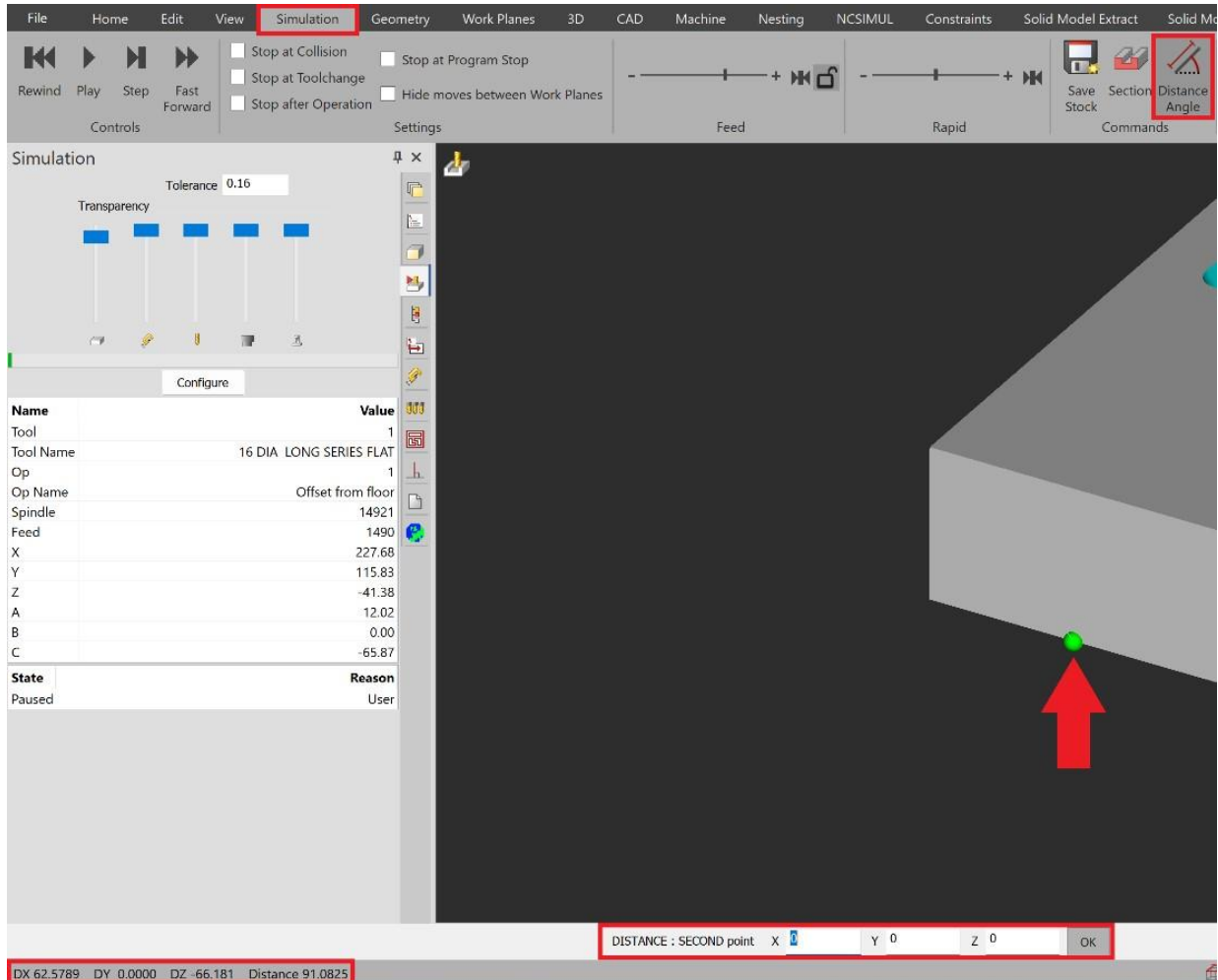

Configuration

Configuration - The addition of a Global Tolerance setting

On the **Home** tab, within **Configure > General > Settings**, a new **Use Global Tolerance** setting has been added with a check box and an edit control. By default, the new tolerance setting will be deselected and the edit control will be disabled but, when the check box is selected, the edit control will become active and a tolerance value can be entered. The tolerance value has been limited to eight decimal places.

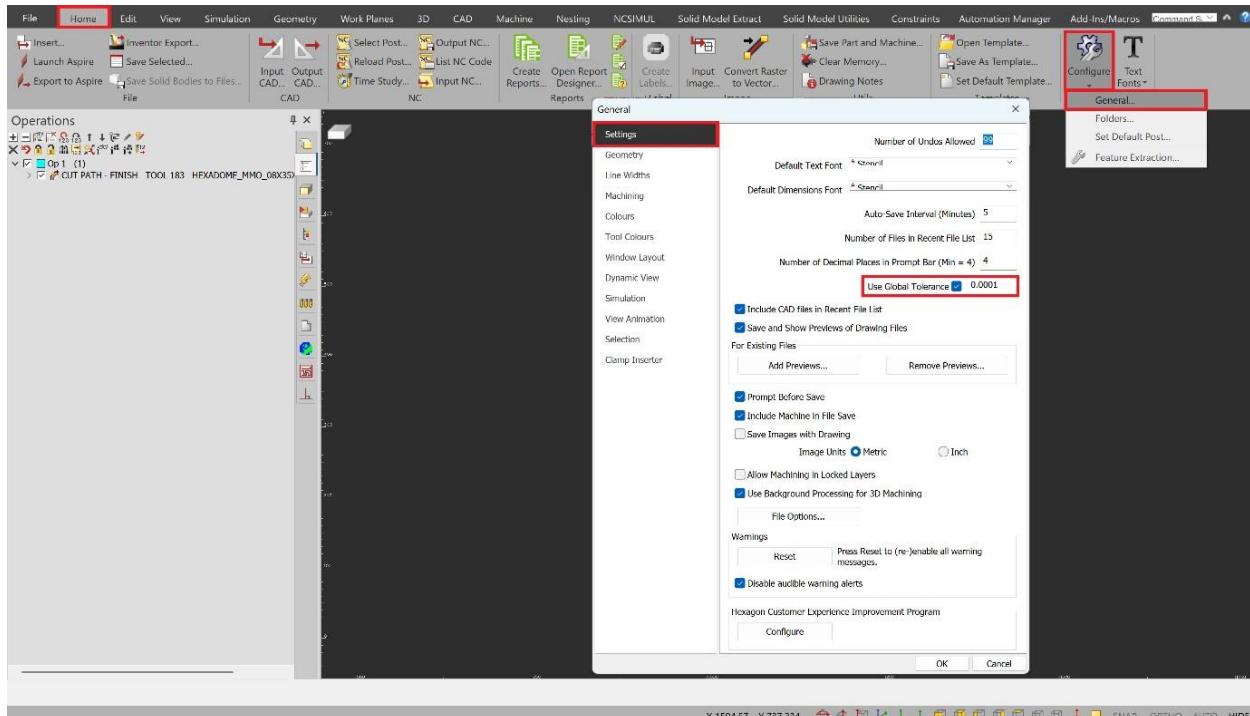

When **Use Global Tolerance** is selected, ALPHACAM will use the user defined value instead of the value that would have been derived from the Post . When the **Use Global Tolerance** setting is deselected, ALPHACAM will work as it did before using a tolerance based on the number of decimal digits set by the Post Processor for coordinate output (\$722).

When outputting NC, ALPHACAM reverts to using the tolerance setting defined in the Post Processor. When NC output is complete, the tolerance values revert to their previous values (i.e. user values if **Use Global Tolerance** is on).



The **Use Global Tolerance** setting and tolerance value are saved and loaded from the registry. There is only one setting for the whole of ALPHACAM which is used in all modules.

File

File - Save As 2024

File Save As will now list 2024, 2023 and 2022 as options. Each should save a file compatible with the appropriate version of ALPHACAM:

- If the drawing contains new 2025 Advanced 5-Axis operations, they cannot be saved into an older drawing file version. A warning message will be displayed, and the file will not be saved.
- If the drawing contains any of the new 2025 type attributes on any entities, a warning message will be displayed asking whether or not you wish to continue.

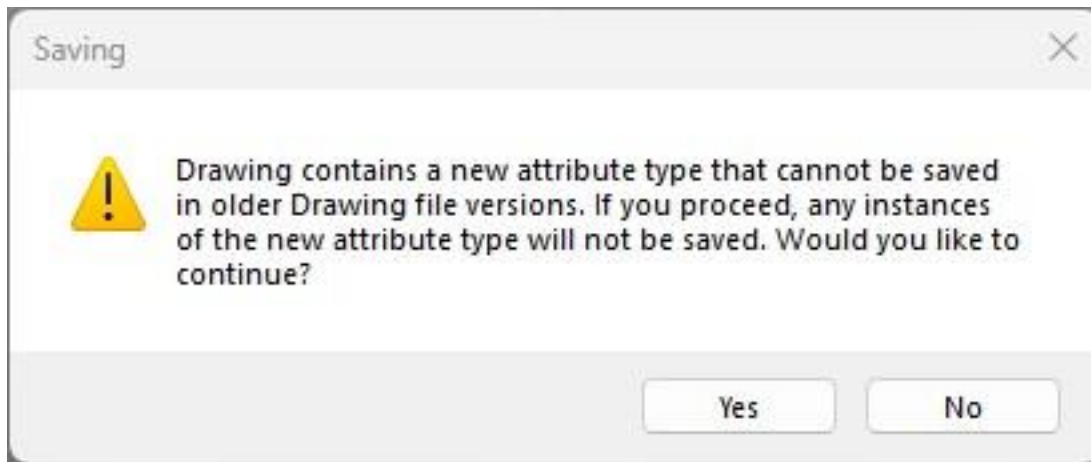

User Interface

User Interface - Improve Solid Model rendering

Parasolid solid models are now rendered at a higher quality. This increased accuracy means that details on the model can be seen more clearly and both surfaces and edges will look smoother. This reduces the need to manually refresh the display after zooming into the model using **Ctrl + R** or **Radial Menu - Refresh**.

Display Options

Display Options - Ghost Tools - Make same colour as associated Geometry

Ghost tools within a drawing are now rendered in the same colour as the entity with they are associated.

Certain commands that show ghost tools on an individual path basis, such as Saw Extensions and Tool Directions, will also colour the markers according to the Geometry/Toolpath with which they are associated.

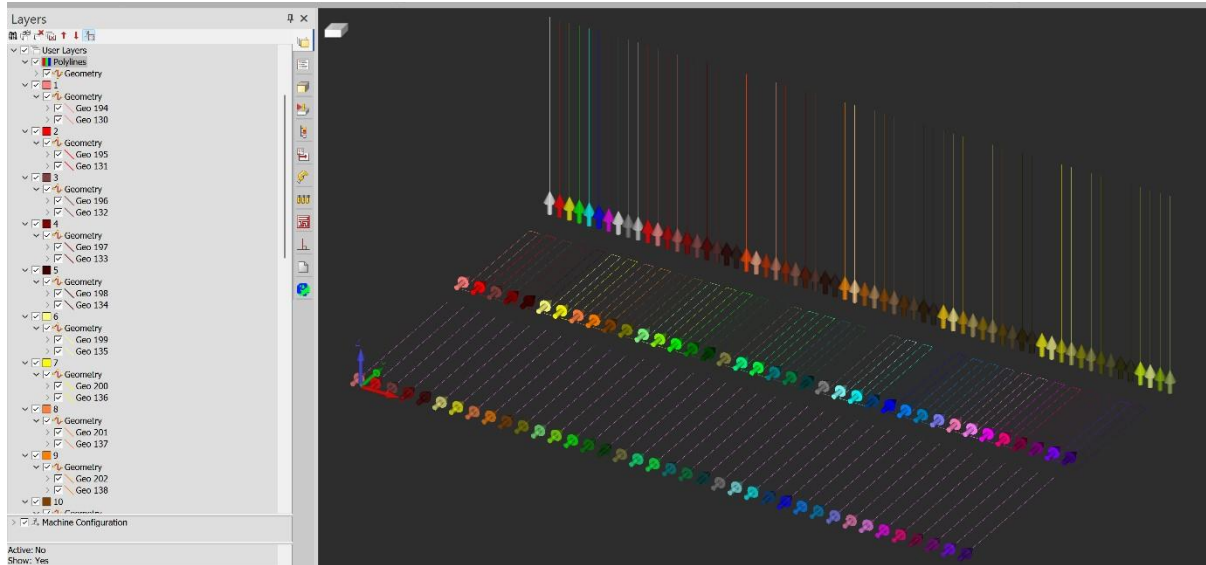

To restore the previous Ghost Tool behaviour, a **Draw Ghost Tools in white** option has been added to **View > Display Options > Display Configuration**.

Display Configuration ×

Draw Geometry Nodes

- Start
- End
- Connection
- Centre
- Arc

Marker Size



Marker Size can be adjusted by holding CTRL and moving the Mouse Scroll Wheel. Hold CTRL and press the Mouse Scroll Wheel to reset.

Options

- Show Markers on Locked Layers
- Draw Ghost Tools in white

Automation Manager

Automation Manager - CSV Import - Use Job Defaults when Create Jobs on Import option is active

The recently introduced Job Defaults are now available when importing a CSV with the **Create Job** option active.

If the **Create Jobs on Import** option is active and the CSV does not have the following fields defined, Automation Manager will take the default settings for these from the **Job Defaults** section of the **Default Settings** tab:

- Configuration.
- Layer Mapping Setup.
- Machining Order.
- Materials.



- If they are not defined in either the CSV or within the **Default Settings** tab, the fields will remain empty.
- If the CSV contains the fields, they will take priority over the defined **Default Settings**.

Automation Manager - Nesting - Improve usability of Angle settings

Additional 90° and 180° options have been added to the **Nest Part Rotation Method** of an Automation Manager job file and the **Free Rotation** option has been renamed to **Any Angle** for consistency with core Nesting. The **Nest Rotation Angle** job file property has also been removed.

Job File	Length (Along Y)	Width (Along X)	Quantity Required	Thickness	Nest Part Rotation Method
Panel_Holes_Pocket_1.ard	500	500	1	0	90 Rotation
Panel_Holes_Pocket_2.ard	200	500	1	0	90 Rotation
Panel_Holes_Pocket_3.ard	500	300	1	0	180 Rotation
Panel_Holes_Pocket_4.ard	150	200	1	0	180 Rotation
Panel_Holes_Pocket_5.ard	500	250	1	0	Any Angle
Rotation Test Part.ard	500	500	1	10	Any Angle

Main Settings

Filename: C:\Users\matthew.diggins\OneD...

Part Name: Panel_Holes_Pocket_1.ard

Layer Mapping Setup: From Job

Machining Order: From Job

Materials

Material: From Job

Part Settings

Item Number: 1

Length (Along Y): 500

Width (Along X): 500

Default Material Thickness: 0

Part Origin: No Change

Use Vector Alignment:

Turn Part Over For Machining:

Drilling Configurations: Select Drilling Configurations

Nested Part Settings

Nest Part:

Quantity Required: 1

Nest Part Rotation Method: 90 Rotation

Try Mirrored Shape: 90 Rotation

Nest Priority: 180 Rotation

Nest Kit Number: Any Angle

Small Nested Part: Fixed

Include Solid Parts: Grain In X

Ignore 3D Paths: Grain In Y

Ignore Paths on Work Planes (Exc...): Grain In X (Allow 180 Rotation)

Extra Part Gap: Grain In Y (Allow 180 Rotation)

Parametric Variables

Custom Fields

Nest Part Rotation Method

CSV Import

The **Nest Part Rotation Method** within **Import Settings** has been extended to accommodate the new settings; 90° Rotation and 180° Rotation are now recognised. **Free Rotation** has also been extended to accept the **Any Angle** value to match the new options.

Legacy CSV Import Settings will now write the new values for the Rotation method, for example, 'Free Rotation' and 'Nest Rotation Angle = 90' will now be imported as 'Rotate 90' in the 2025 version. The legacy 'Rotation Angle' import setting field will now be flagged with (OBSOLETE From 2025.1).

Nest Part Rotation Method (Field Position: 3 (C))

Specify a rotation method to be used when nesting.

Accepted Value(s):

Fixed: Fixed, 0.

Grain In X: Grain In X, GrainInX, 1.

Grain In Y: Grain In Y, GrainInY, 2.

Free Rotation: Any Angle, Free Rotation, Free, 3.

Grain In X (Allow 180 Rotation): Grain In X (Allow 180 Rotation), GrainInXAllow180Rotation, 4.

Grain In Y (Allow 180 Rotation): Grain In Y (Allow 180 Rotation), GrainInYAllow180Rotation, 5.

90 Rotation: 90 Rotation, 6.

180 Rotation: 180 Rotation, 7.

Compatibility with earlier versions of ALPHACAM

As far as is possible, the new work has been designed to work with previous versions of ALPHACAM.

The first time the 2025.1 version of Automation Manager is opened, all existing Job File data is processed and the new values populated, the affected areas are Job Files and Job File Defaults.

Changes made to Job Files in Automation Manager 2025 are visible and still work correctly in 2024 and earlier:

- 'Any Angle' in 2025 will be 'Free Rotation' and Nest Rotation Angle = 360 in 2024.
- 'Rotate 90' in 2025 will be 'Free Rotation' and Nest Rotation Angle = 90 in 2024.
- 'Rotate 180' in 2025 will be 'Free Rotation' and Nest Rotation Angle = 180 in 2024.



Changes made in 2024 will NOT be visible in the 2025 version.

Automation Manager - Layer Mapping - Inform the user what is unused/used and by what

If a user deletes a Layer Mapping Setup which is in use by Automation Manager jobs or is currently set as the default setting in Job Defaults within the Default Settings tab, Automation Manager will display a message confirming whether the user wants to delete this setup. If the user chooses **Yes** and the Layer Mapping Setup is in use, a dialog will open displaying which jobs are using this setup and whether it is set as a default setting.

Selecting **OK** on the feedback dialog will proceed with deleting the setup, otherwise, the user can select **Cancel** and the setup will not be deleted.

	Any jobs that were using the now deleted Layer Mapping Setup will show the default message of 'No Setup Selected' within the Layer Mapping Setup section in the Processing tab; this is the same for default settings.
---	--

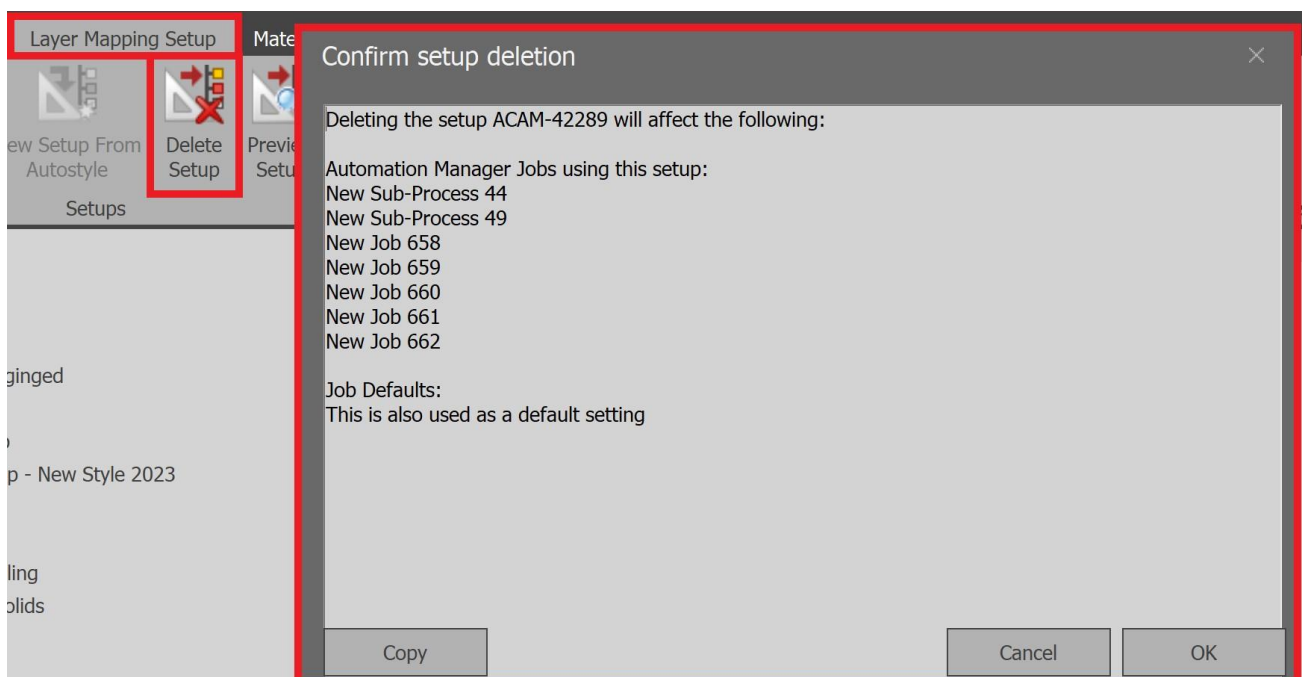











Automation Manager - Multi select Job Files to Process

It is now possible to select multiple Job Files or CDM doors using CTRL + Left Mouse Click and process only the selected files.

A new **Process Selected Item(s)** right click menu option has been added which will only process the current selected files. The user can also press the **Enter** key to process the selected files and, when doing so, a message will be displayed asking the user to confirm whether they wish to proceed.





This functionality is only supported for Automation Manager Job Files and CDM Doors and cannot be used for Subcomponents or Multiple Process Jobs.

Job File	Length (Along Y)	Width (Along X)	Quantity
  Panel_Holes_Pocket_1.ard	500	500	1
 Panel_Holes_Pocket_2.ard	200	500	1
  Panel_Holes_Pocket_3.ard	500	300	1
 Panel_Holes_Pocket_4.ard	150	200	1
  Panel_Holes_Pocket_5.ard	500	250	1
  Rotation Test Part.ard	500	500	1

-  Copy Job File(s)

-  Remove File(s) From Job

-  Update Parametric Variables

-  Remove Parametric Variables

-  Read File Information

-  Auto-Associate Sheets

-  **Process Selected Item(s)**

Automation Manager - Option to align by minimum 3D bounding box for irregular shaped parts

A new **Use Minimum Bounding Box Alignment** option has been added to the **Part Settings** within the **Processing** tab. When active, the longest edge of the part will align with either the X or Y-Axis. A new CSV import field has also been added and accepted values are displayed in the property grid of the field within the **Import Settings** tab.



The new functionality only supports Solid parts and will not work with Geometry drawings.

Automation Manager - A ribbon button to highlight unused Layer Mapping Setups

To assist users in distinguishing unused Layer Mapping Setups in Automation Manager, a new **Highlight Unused Setups** option has been added to the **Layer Mapping Setup** ribbon and the right click context menu of the main Layer Mapping Setup node and of each Setup.

Once clicked, it will highlight all the unused Layer Mapping Setups that are currently not in use by any of the jobs/job files in Automation Manager or not set as the Default Configuration in Job defaults within the Default settings tab.

Any unused Layer Mapping Setups will be highlighted in yellow and hovering over the highlighted node will display a 'This Setup is not in use' tooltip. Switching to another tab and back to Layer Mapping Setup will remove the highlights.



Automation Manager - Layer Mapping – Improve feedback on missing Styles

A new **Show Missing Machining Styles** ribbon button has been added to the **Layer Mapping Setup** tab and the right click context menu of the main Layer Mapping Setup node. Clicking this button will expand the layer mapping setups which contain missing machining styles that have been either deleted or moved from their specified file location. Nodes with missing styles will be highlighted in yellow and, when hovered over, a 'Missing Machining Style' tooltip will be displayed.

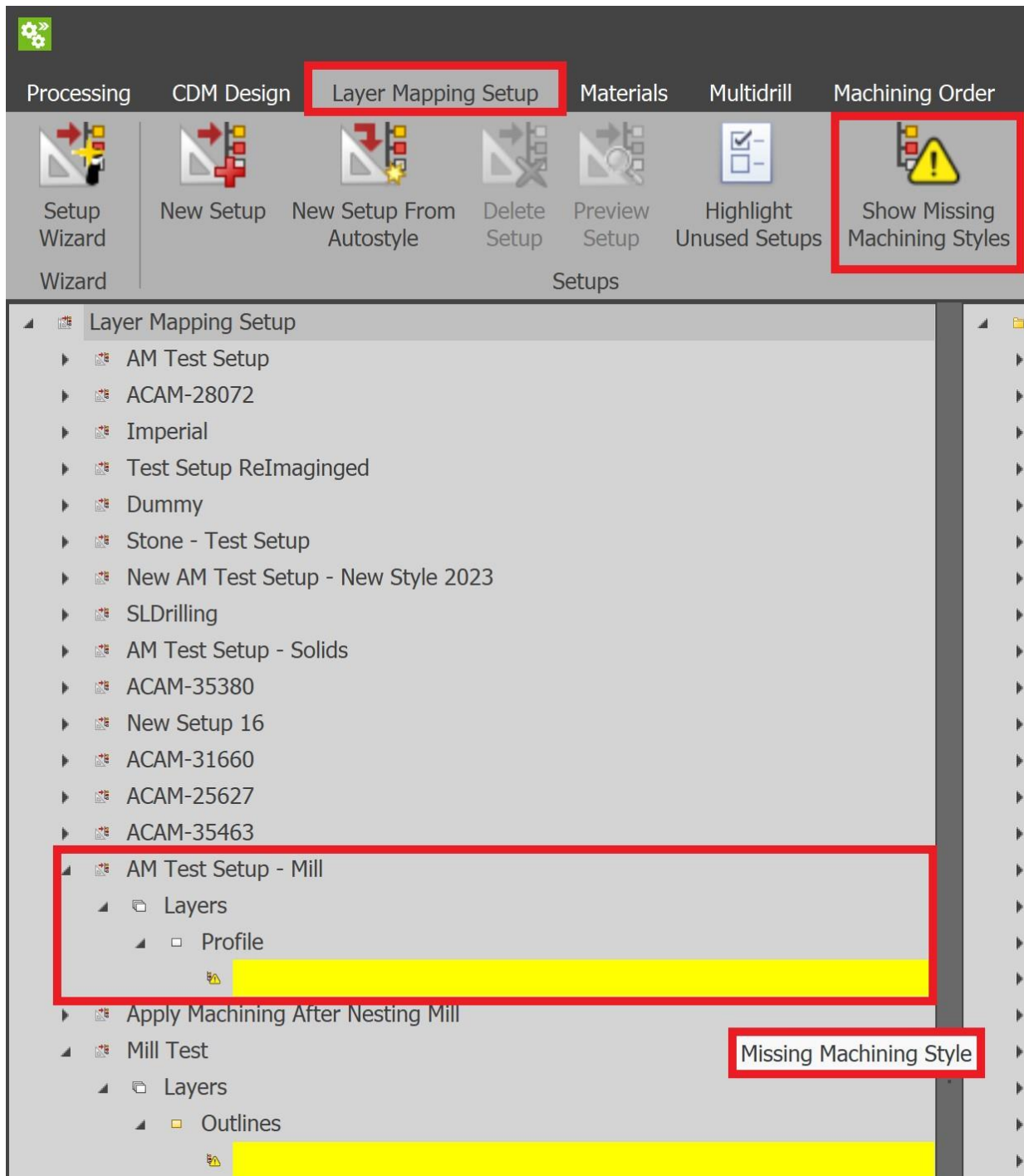

If the user clicks on the new button and there are no missing machining styles, a 'There are no missing machining styles' message is displayed.

Unlike other areas of highlighting in Automation Manager, the highlighted Layer Mapping setups will not lose their highlight when toggling between tabs.



While in an active session of Automation Manager, if you were to delete a machining style from file explorer and then switch tab and then return to Layer Mapping setups, the deleted style will be highlighted but their names will still be visible. This is an existing behaviour to see the updates that the user will need to close and reopen Automation Manager in order for the missing style names to be removed from the tree.

Reports

Reports - Filled colour images for Parts and Nested Sheets

A new **Filled Colour** option has been added to the **Image Type** field in the **Report Data Settings** dialog. When selected, Nested sheet images and Parts/Nested Parts will be output in a solid colour to assist with part identification.

Report Data Settings
✕

Data Settings File Name

C:\ALPHACAM\LICOMDIR\Reports\Settings\New Reports Settings.acreps Save As...

Nested Sheets

Image Type Filled Colour

None
 Background Wireframe Black
 Wireframe Colour
 Image Shaded Greyscale
 Shaded Colour
Image Filled Colour

Line Thickness (Default = 0.22)

Filled Colour View Detail Both

None
 Part Text
 Part Identifiers
Both

Suppress Item Number

Suppress Toolpaths from Images

Create Operation Data

Sheet Load Time (seconds)

Parts/Nested Parts

Image Type Filled Colour

None
 Background Wireframe Black
 Wireframe Colour
 Image Shaded Greyscale
 Shaded Colour
Image Filled Colour

Line Thickness (Default = 0.22)

Filled Colour View Detail Part Text

None
 Part Text
 Part Identifiers
Both

Secondary Image

View

Suppress Toolpaths from Images

Show Direct Input

Create Operation Data

Part Load Time (seconds)

Operations

Tool Image Type

Background Colour ...

Image Width

Image Height

Include Tool Holder in Images

General

Efficiency Rate (%)

Capture CDM Data

Capture Cad To Cam Data

Capture Custom Attribute Data

❗ Creating shaded images can dramatically increase the time it takes to create the report data.

OK

Cancel

If the **Filled Colour** option is selected, additional options become available:

- **Nested Sheets – Filled Colour View Detail:**
 - **None** – No text or part identifier text will be displayed on the nested sheet image.
 - **Part Text** – Any text present on the nested parts will be displayed on the nested sheet image.
 - **Part Identifiers** - The part identifier text will be displayed on the nested sheet image.
 - **Both** – Any text present on the nested parts and the part identifier text will be displayed on the nested sheet image.
- **Part/Nested Parts – Filled Colour View Detail:**
 - **None** – No text or part identifier text will be displayed on the part image.
 - **Part Text** – Any text present on the nested parts will be displayed on the part image.
 - **Part Identifiers** - The part identifier text will be displayed on the part image.
 - **Both** - Any text present on the nested parts and the part identifier text will be displayed on the part image.





ALPHACAM BY  HEXAGON

Job: Both_Both
Customer: New Report Colour
PO: **Due: 01/22/2025**

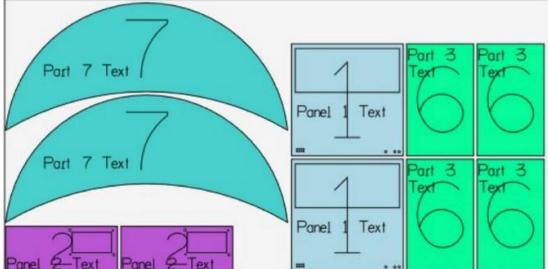
Sheet A1
 Material: MDF
 Width: 2440
 Length: 1220
 Thickness: 10
 CycleTime (H:M:S): 0:22:45
 Scrap %: 29



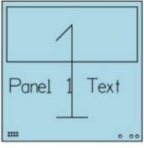

Part Name:	Part Index:	Qty in Sheet:	Part Size:	Part Image:
Panel_Holes_Pocket_1_Text	1	2	500	
			500	
Panel_Holes_Pocket_2_Text	2	2	500	
			200	

Reports - To be able to report on 100 TPD values

Within reports, we have now added support to include additional TPD values to 100. This has been added for both Nested and Non-Nested parts.

	<ul style="list-style-type: none">• Any Machining Styles will need to be updated with the updated tool in order for reports to display the assigned TPD values.• Any ALPHACAM drawings created before the implementation of this work will also need the tool to be updated with the updated/new tool for the TPD values to be displayed in reports.
---	---

Scale 3D XYZ**Scale 3D XYZ - Automatic Scaling of Geometry/Element Z levels**

When a 3D Scale is being performed, we now scale geometry Z levels, element Z levels and material levels (Material Top etc;) if any of them exist.

Additionally, any Hole Level attributes added by Feature Extraction are also updated.

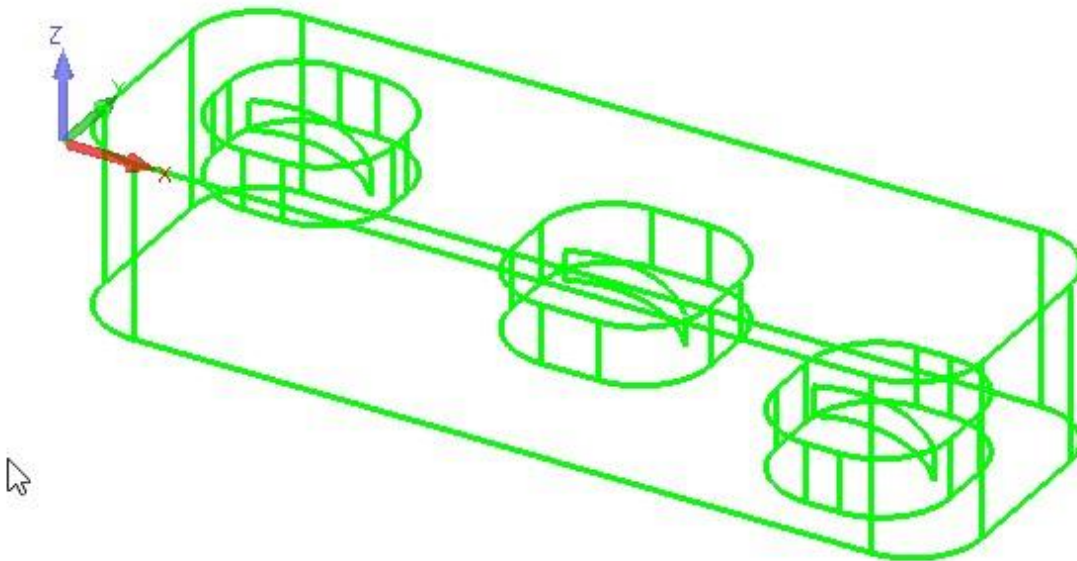

Appendix A - API Improvements in ALPHACAM 2025.1

SimulationMain.SaveSnapshot

If the active view is showing the internal solid simulation, this function will save a screenshot of the view.

SimulationMain.SaveSnapshot(FileName as String, Type as AcamSimSnapshotImageType)

- **FileName** - The absolute path to a valid location to write the image file. The filename should include an extension (.jpg or .png).
- **Type** – image format required, AcamSimPNG or AcamSimJPEG.



VBA Example

```
Sub TestSnapshot()  
  'Open drawing  
  App.OpenDrawing "c:\temp\part.ard"  
  Dim drw As Drawing  
  Set drw = App.ActiveDrawing  
  Dim SimInterface As SimulationMain  
  Set SimInterface = drw.SolidSimulationInterface2  
  'Run simulation  
  SimInterface.SolidSimulation drw, True  
  'Save screenshot  
  SimInterface.SaveSnapshot "c:\temp\test.png",  
  AcamSimPNG End Sub
```

C# Example

```
using  
AlphaCAMMill;  
using  
SolidSimLib; void  
TestSnapshot()  
{  
  string filepath = "c:\\temp\\Part.ard";  
  AcamApp.OpenDrawing(filepath);  
  Drawing Drw = AcamApp.ActiveDrawing;  
  SimulationMain SimInterface =  
  (SimulationMain)Drw.SolidSimulationInterface2;  
  SimInterface.SolidSimulation(Drw, true); string imagepath =  
  "c:\\temp\\Snapshot.png";  
  SimInterface.SaveSnapshot(imagepath, AcamSimSnapshotImageType.AcamSimPNG);  
  Marshal.ReleaseComObject(SimInterface);  
  Marshal.ReleaseComObject(D  
  rw); }
```

Supported CAD File Versions

	To import Solid CAD files, the xSolids multiplier is required.
	In order to import Autodesk Inventor files, Autodesk Inventor® or Inventor® Apprentice Server™ must also be installed.

Translator and Version

- ACIS R1 – 2025 1.0
- Adobe Illustrator
- Adobe PDF
- ALPHACAM Designer Files
- Autodesk Inventor 2026
- Creo 12.4
- DXF/DWG (AutoCAD 2018)
- IGES (not version specific)
- JT Open 10.10
- NX Unigraphics UG11 – NX 2506
- Parasolid 9.0 v37.0.185.1
- Part Modeler (current)
- PostScript
- Rhino 7.0
- SketchUp 2022
- Solid Edge V18 – SE 2025
- SOLIDWORKS 2026
- Spaceclaim 2019 R1
- STEP AP203/AP214/AP242 (preferred Schemas)
- STL (not version specific)
- VISI Version (current)

Extra Cost**Translator and Version**

- Catia V4 4.1.9 - 4.2.4
- CATIA V5 R8 - V5-6R2025
- CATIA V6 Up to V6 R2025



CATIA V6 users should export their database objects as CATIA V5 CATParts or CATProducts.

Recommended System Specifications

The suggested computer specifications to ensure the best experience when using ALPHACAM.

Component	Recommended Specification	Minimum Specification
CPU	Intel Core i7 or i9 (12th generation or higher) or AMD Ryzen 7 or Ryzen 9	Intel Core i5 (10th generation or higher) or AMD Ryzen 5
RAM	32 GB DDR5	8 GB DDR4
Storage	1 TB NVMe SSD	256 GB SSD
GPU	NVIDIA RTX (Workstation/Quadro range) or AMD Radeon Pro (6–16 GB VRAM)	NVIDIA Quadro or AMD Radeon Pro (2–4 GB VRAM)
Display	1920×1080 (Full HD) or 2560×1440 (2K) or 3840×2160 (4K) IPS monitor, 27 inches or larger	1920×1080 (Full HD)
Mouse	3-button optical mouse or 3D mouse (for example, SpaceMouse)	3-button optical mouse
Operating System	Windows 11 Pro (64-bit)	Windows 11 Pro (64-bit)

System Requirements

The minimum computer specifications required for the software to run and be supported.

Operating System

ALPHACAM 2025.4 operates under 64-bit Microsoft Windows 11 Professional on an x64 based processor.

We recommend you install the latest service packs for the supported operating systems.

	<p>ALPHACAM can be installed and run on the Home editions of the supported operating systems. However, this is not recommended, and we cannot guarantee resolution of issues that are specifically related to these editions.</p>
---	---

Microsoft .NET Framework

Microsoft .NET Framework 4.7.2 or higher for Windows. For information on .NET Framework dependencies, see [Versions and Dependencies](#).

When installing:

- You update to the latest security key drivers (if a security key is fitted).
- You may experience problems with the driver supplied by your graphics card manufacturer. You must check for the latest driver updates on the website for your card.

RAM

8 GB

Graphics

You must use a high quality, dedicated Graphics card with its own memory. The latest WHQL-certified driver must support OpenGL 3.3 or higher.

- NVIDIA Quadro or RTX Workstation Series(<http://www.nvidia.co.uk/Download/index.aspx?>)
- AMD Radeon Pro Series (6–16 GB VRAM) (<https://www.amd.com/en/support>)



Some older cards in the ranges listed above may no longer be supported. Please check with the respective manufacturer to confirm whether an up-to-date driver is available for your operating system. Other graphics cards may function, but they are not officially supported.

Hard Drive

10 GB free disk space for the ALPHACAM installation

Display

17 inches Color Monitor (1280 x 1024 screen resolution)

Mouse

- Mouse including wheel (Intellimouse)
- SpaceMouse/SpaceBall (Optional)

Connectivity

- Internet connection for license activation or updates.
- Network Card.

Licensing

The Sentinel RMS License Manager runs as a system service on Windows 10 and Windows Server up to and including the latest release. Sentinel RMS network licenses can be installed on virtual servers if they are locked to a Computer ID USB key.



The Sentinel RMS License server can be installed on Windows 7 and Windows 8.1, but since these operating systems are no longer supported by Microsoft, this is not recommended. Standalone (single seat) Sentinel RMS licenses cannot be locked to the Computer ID USB keys for use on a virtual server.

Installation

It is not recommended to have multiple ALPHACAM versions installed on the same computer when you have limited rights or User Account Control (UAC) is enabled, as this may potentially cause issues.



Browsers

Microsoft Edge or Google Chrome

Windows ARM

ALPHACAM no longer supports Windows ARM.

Install ALPHACAM

To install ALPHACAM, follow these steps:

Step 1: Check System and Hardware Requirements

Before you attempt to install a new version, ensure that you meet the system and hardware requirements discussed in [Recommended System Requirements](#).

- To get your computer's properties, highlight the **This PC** icon, right-click on it, and select **Properties**.
- To check the display properties for the graphics card, go to **Start**, click **Settings**, select **System**, and then select **Display**.

You must also have a valid license for the installation to work.

	To run ALPHACAM 2025.4, the maintenance expiry date in your license must be March 2025 or later.
---	--

Step 2: Log on as an Administrator

To install and run your new version for the first time, you must be logged on as a user with administrator privileges.

Step 3: Download ALPHACAM

1. Open a web browser and navigate to the [Hexagon Customer Portal](#).
2. Enter your username and password and click **Sign In** to access your account.
3. To open the **Software** page, click **Software** or click **Downloads > Software**.
4. Navigate to the ALPHACAM 2025.4 details.
5. Click **ALPHACAM 2025.4.zip** to open the **Download Details** screen.
6. Click the **Download** button to begin downloading the file to your computer. By default, Microsoft Windows saves downloaded files in the **Downloads** folder.

Step 4: Install ALPHACAM

1. Right-click the **ALPHACAM 2025.4.zip** file.
2. Select **Extract All** and then select the location where you want to save the extracted files.
3. Open the **ALPHACAM 2025.4.zip** folder and then open the **ALPHACAM 2025.4.zip**.
4. Right-click on this executable file and click **Run as administrator** to open the installation program.
5. If a security warning appears, click **Yes**.

6. Select the language to use during the installation.
7. Click **OK**.
8. From the **License Agreement** screen, read the license agreement, and select the **I accept the agreement** option.
9. Click **Next** to open the **Join the Hexagon Customer Experience Improvement Program** screen.
10. In the **Join the Hexagon Customer Experience Improvement Program** screen, read the information about the program. To help improve the product and send usage data to Hexagon Manufacturing Intelligence, select **Yes, I want to join**. To opt out of sending usage data, select **No, thank you**. For more information about this program, visit the [Hexagon Customer Experience Improvement Program](#) website.
11. Click **Next**.
12. You can choose to install additional software components, resources, and shortcuts.
 - **Aspire for ALPHACAM:**
 - **NCSimul Essential:**
 - **Install example files and utilities:**
 - **Create a desktop shortcut:** Creates a shortcut to quickly access ALPHACAM from your desktop.
13. Click **Next** to open the **System Folders** screen.
14. In the **System Folders** screen, you can set the installation folder for LicomDat, LicomDir, and example files and utilities. By default, the installation location is:
 - **LicomDat:** C:\ALPHACAM
 - **LicomDir:** C:\ALPHACAM
 - **Example files and utilities:** C:\Users\Public\Documents\ALPHACAM\2025.4
15. Click **Next** to open the **Ready to Install** screen.
16. Click **Install** to start the installation. Click **Back** to review or change any settings.
17. When the installation finishes, the **Completing the ALPHACAM Setup Wizard** appears and displays this option.
 - **Launch ALPHACAM** - To launch ALPHACAM 2025.4 now, select this check box.
18. Click **Finish** to close the installation program.

Update ALPHACAM

The Hexagon Universal Updater application automatically checks for software updates if your computer is connected to the Internet. If the updater detects that an update is available, the updater uses the Windows notification area to the right on your taskbar to inform you of the update. You can then click on a notification to open the updater to download and install that update.

- If the updater is running, a small icon for the updater appears in your taskbar's Notifications area. You can click this icon to open the updater.
- If the updater is not running, you can manually run the updater to check for updates. You can also use the updater to launch software or install new software applications. To run the updater, from the **Start** menu, type **Universal Updater**, and select the shortcut for the updater.

If you need additional help with the updater, you can access the help content available from within the updater itself.

For information on the installation process, follow the installation steps described in the Install ALPHACAM section. Once the installation process finishes, you can use the latest version.

Contact Hexagon Manufacturing Intelligence

If you are using the commercially-released version of ALPHACAM 2025.4 and would like further information or technical support, please contact hexagon.com/about/contact-us. You can also reach Hexagon Technical Support at hexagon.com/support-success/manufacturing-intelligence/production-support or contact your local ALPHACAM supplier or authorised reseller to provide support, licensing assistance, and region-specific guidance.